

SECTION R L/F TRANSMITTERS (WITH H/F ATTACHMENTS)

D.C. SUPPLY TO MAIN OFFICE	PAGE	RA2
AUXILIARY OFFICE POWER SUPPLY	"	RA4
TYPE 31	"	RB2
" 34A	"	RC2
" 35S	"	RD2
" 36S	"	RE2
" 36m	"	RE22
" 37S	"	RF 2
" 37M	"	RF14
" 38S	"	RG2
" 43	"	RH 2
" 44	"	RI 2
" 45	"	RJ 2
" 46	"	RK2
" 47	"	RL2
" 48	"	Rm2
" 49	"	RN2
" 50	"	RO2
" 51	"	RP2
" 51HX	"	RPIO

D.C. SUPPLY TO MAIN W/T OFFICE.

Although the circuits supplying power to the W/T office are the responsibility of the Torpedo Department (see page AA5), the fact that the local control switches for the ring main breakers are fitted inside the W/T office renders it desirable for telegraphist ratings to understand their action, and the circuits fitted.

The main D.C. supply from the ring main through the branch breakers to the ring main C.O.S. is shown in figure d. Figure c. shows another arrangement which is fitted in some of the later classes of ships. Both figures have been simplified to give a general idea of the circuit and full details can be found in the Naval Electrical Manual 1926 Volume II Chapter 2.

D.C. SUPPLY (AS FITTED IN "NELSON," "LONDON" AND "YORK" CLASSES.)

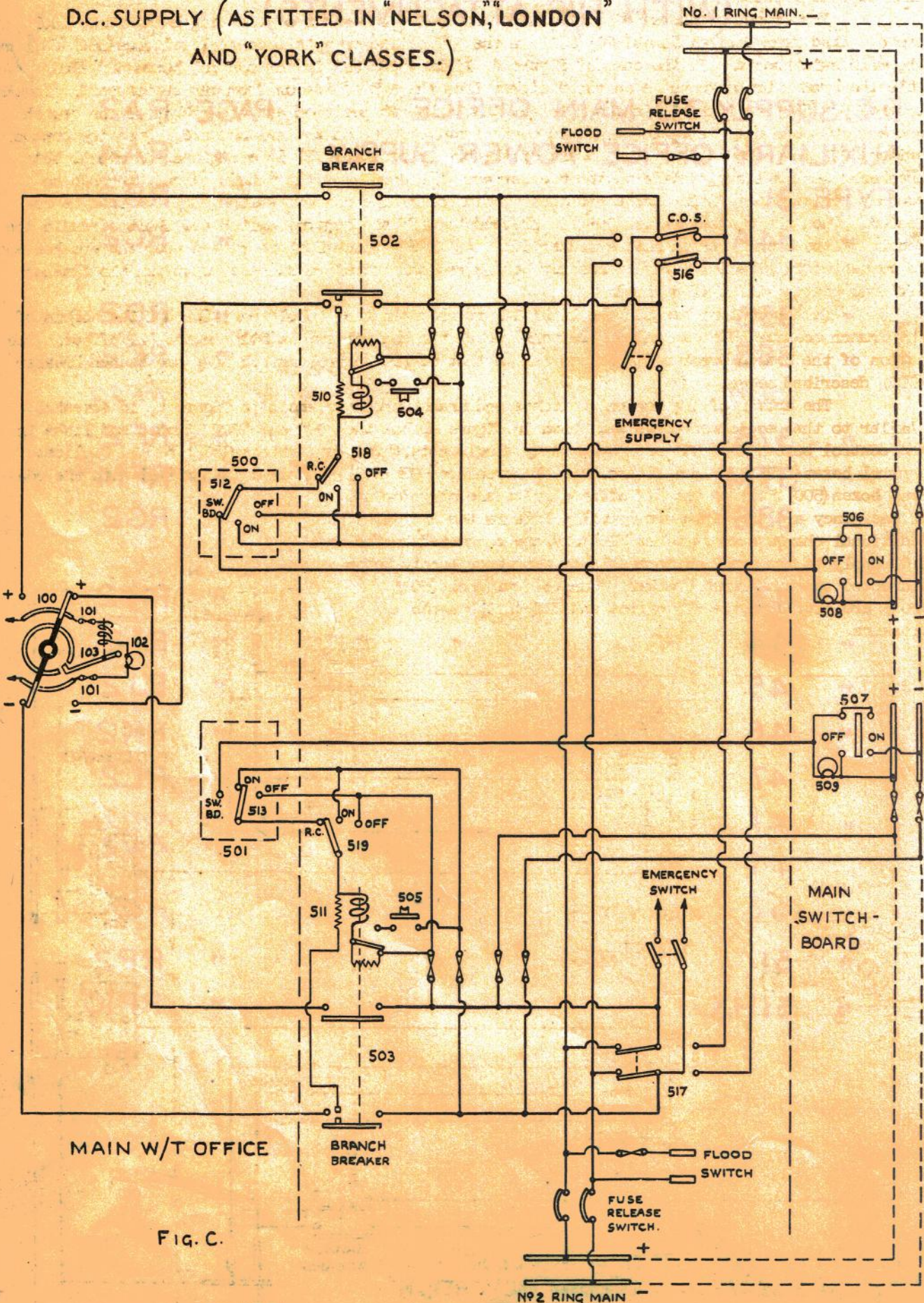

FIG. C.

The D. C. supply from the ring main is connected via branch breakers (502) (503) to the ring main change over switch (100) which has a locking device to prevent its being damaged by changing over when a large current is flowing. The locking device consists of a solenoid bobbin with a lamp (102) in series which is connected across the centre contacts of the ring main C. O. S. (100). When power is supplied to the ring main C. O. S. (100) from either ring main the bobbin is energised and attracts a locking bolt (103) which engages in a slot on a plate secured to the switch spindle. The switch (100) cannot, therefore, be moved until power is taken off and the locking bolt (103) released. Care should be taken that the fuses (101) and lamp (102) are intact as the removal or breakage of any of them will make the solenoid coil inoperative and thus allow the C. O. S. (100) to be changed over with current flowing.

The branch breakers (502) (503), which supply the two sides of the ring main C. O. S. (100) are operated from control boxes (500) (501) in the W/T office or by the control switches (506) (507) on the main switchboard. In the case of figure d, links (512) (513) in the control boxes (500) (501) enable the branch breakers to be operated either from the W/T office or from the switchboard. In the control box (500) the link (512) is shown in the "Switchboard" position and the bobbin of the branch breaker (502) can only be operated by the control switch (506) on the switchboard. When the control switch (506) is pushed to "ON" the bobbin of the branch breaker (502) is energised and closes the breaker. An auxiliary contact on the breaker arm then completes the bobbin circuit through an economy resistance (510) in series with the bobbin coil. The control switch (506) can then be released. When the control switch (506) is pressed to "OFF" the control switch arm short circuits the bobbin of the breaker which then switches off. An "OFF" switch (504) is fitted near the breaker and is connected in parallel with the breaker bobbin and can therefore be used to switch the breaker off from that position if desired.

In the control box (501) the link (513) is shown in the "Local" position and the bobbin of the branch breaker (503) can only be switched on by the control switch (501) in the W/T office. The action of the branch breaker (503) is similar to that of the control switch (506) and branch breaker (502) described above.

The action of the control switches and branch breakers shown in figure c, is somewhat similar to that explained above and shown in figure d, but the "ON" and "OFF" pushes and links in the control boxes (500) (501) are replaced by single pole, three way switches (512) (513). Duplicate control boxes (518) (519) are fitted near the breakers (502) (503) and wired in parallel with the control boxes (500) (501) in the W/T office; these are only for use in an emergency and the links are normally left in the R. C. position. Additional change over switches (516) (517) are connected to the main D. C. supply to the breakers to enable an emergency supply to be connected to each branch breaker. Control switches (500) (501) are fitted in the W/T office and (518) (519) at the breakers.

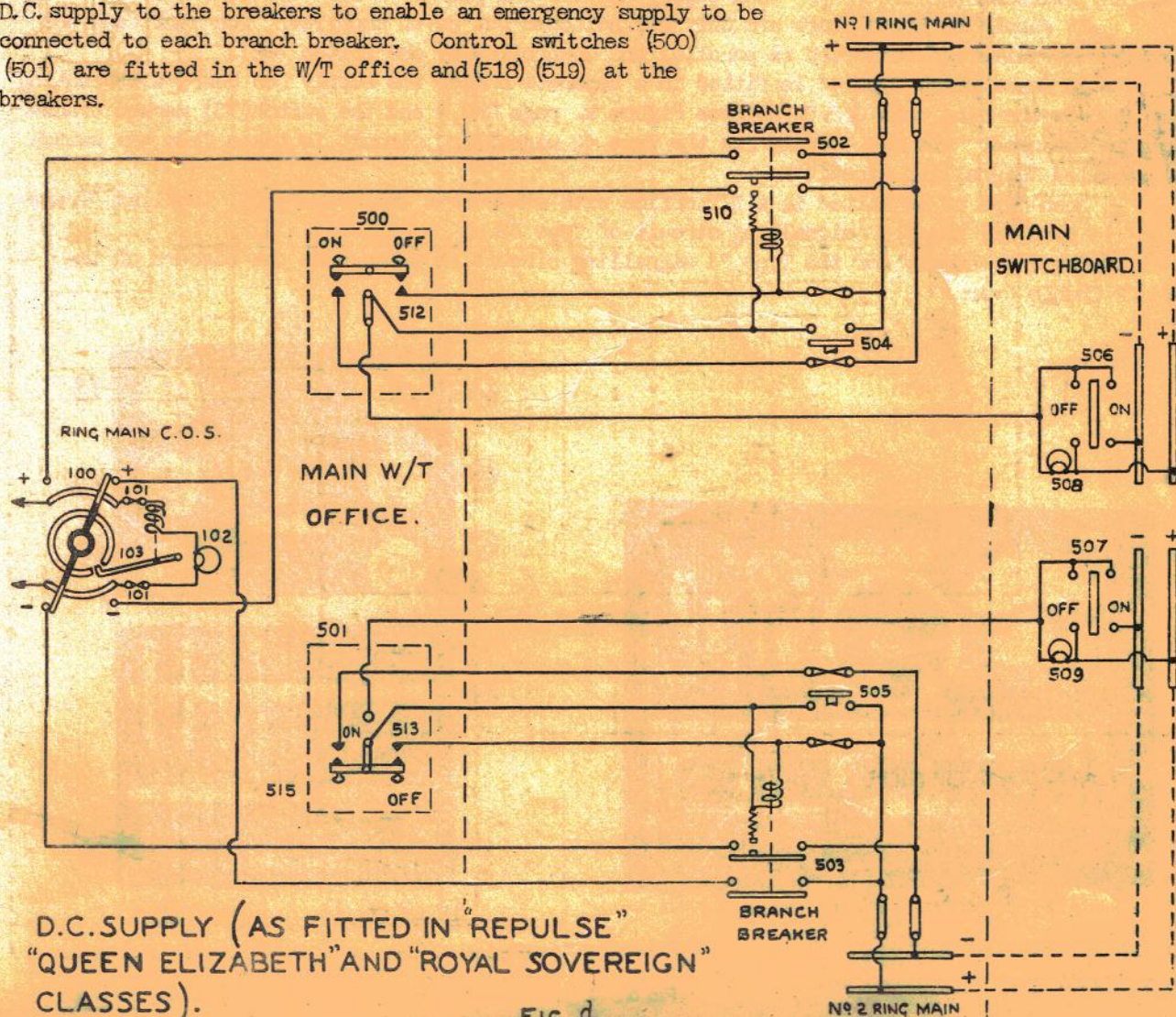

FIG. d

AUXILIARY OFFICE POWER SUPPLY

Board 2D change over. When several low power W/T sets (i.e., Types 43, 45, 71, 151) are fitted in an auxiliary W/T office the power supply for each set is taken from Board 2D Change Over.

This board contains a ring main C.O.S. (112) ammeter (113) four D.P. switches (114)(115)(116)(117), a pair of 30 amp fuses (154) and an electrical locking device circuit consisting of a bobbin (109) lamp (110) and fuse (111).

The ring main C.O.S. (112) is supplied from each side of the ring main, and has a mechanical and electrical locking device which prevents the switch being moved when there is power supply on board 2D. When power is supplied to the C.O.S. (112) the bobbin (109) is energised and pulls an arm up into a slot on the switch and thus locks it. The lamp (110) in the bobbin circuit then lights.

The ammeter (113) is connected in the negative supply from the C.O.S. (112) and indicates the current output to the whole of the auxiliary W/T office.

The four switches (114)(115)(116)(117) are labelled:-

Type 45, Type 43, Type 151, Type 71 and spare.

In cases where Type 71 and/or Type 151 are not supplied from this source either switch may be used to supply Type 75.

The switch (114) connects the supply from the board 2D to board 2B, through a pair of fuses (124) to the Type 45 automatic starter (129) and to the board 2A through a pair of fuses (118) for the Type 45 hand starter (119).

The switch (116) connects the supply from board 2D to the board 2E supply of Type 43. Board 2E has its own ring main C.O.S. (59) and when the set is fitted in a separate W/T office each side of the ring main C.O.S. (59) is connected to each side of the ring main (see page RHC). When Type 43 is fitted with other sets only one side of the ring main C.O.S. (59) is connected, and that side is connected to board 2D and controlled by the D.P. switch (116).

The switch (117) connects the supply from board 2D through two pairs of fuses (154)(152) to the automatic starter (142) of the Type 71 filament generator (146). It also supplies the Type 71 blower and signalling circuits through two pairs of fuses (154)(153). The fuses (154) are 30 amp fuses and are fitted in board 2D.

It should be noted that the Type 71 H.T. generator (145) automatic starter (139) is supplied direct from the busbars of board 2D.

Board distributing 7 way. The board distributing 7 way is similar to that fitted with Type 375. It is supplied from the busbars of the board 2D Change Over through the D.P. switch (62).

Board distributing 7 way supplies the D.C. signalling circuits of Types 43 and 45, lights, fans, radiator and charging arrangements. The supplies to the above are controlled by the six subsidiary switches (63) to (68). Each supply has its own pair of fuses (69) to (75).

It should be noted there are only six switches but seven supplies. The vent fans and circulator circuits are connected in parallel and controlled by one switch (63).

In cases where Type 43 is fitted in a separate office the supply for board distributing 7 way is from the ring main C.O.S. (59) (see figure k. page RH2,) and the switch (73) marked transmitter is not used. The D.C. supply for the Type 43 signalling circuit is taken from the switch (68) labelled "Signalling Circuit".

When Type 43 is fitted in a W/T office with other sets the switch (66) labelled "Transmitter" is used for the D.C. signalling circuit of Type 45.

The D.C. supply for the Type 71 signalling circuit is taken from the busbars of the board 2D Change Over.

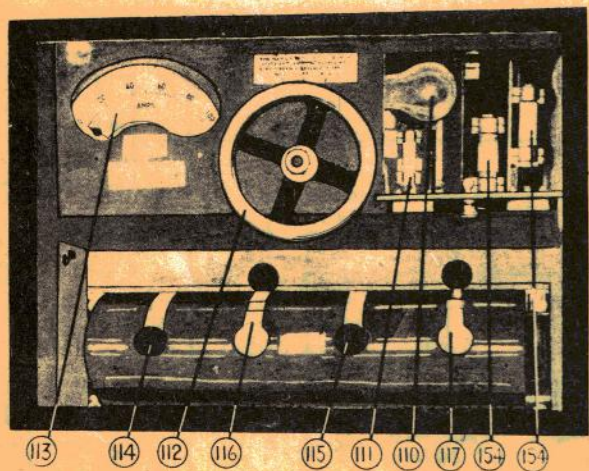

Fig. a.

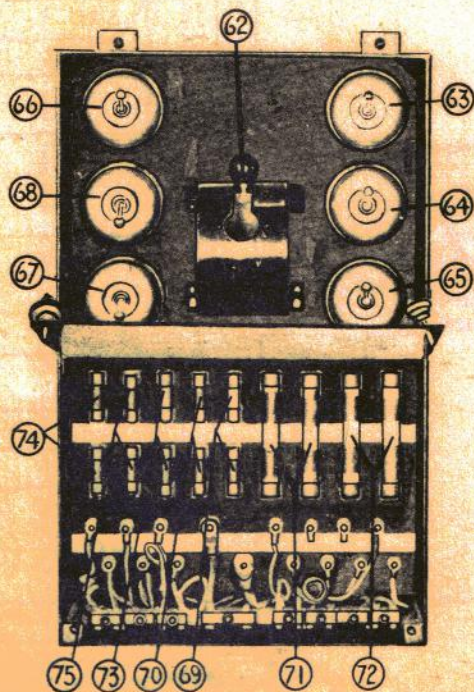

Fig. b.

AUXILIARY OFFICE POWER SUPPLY

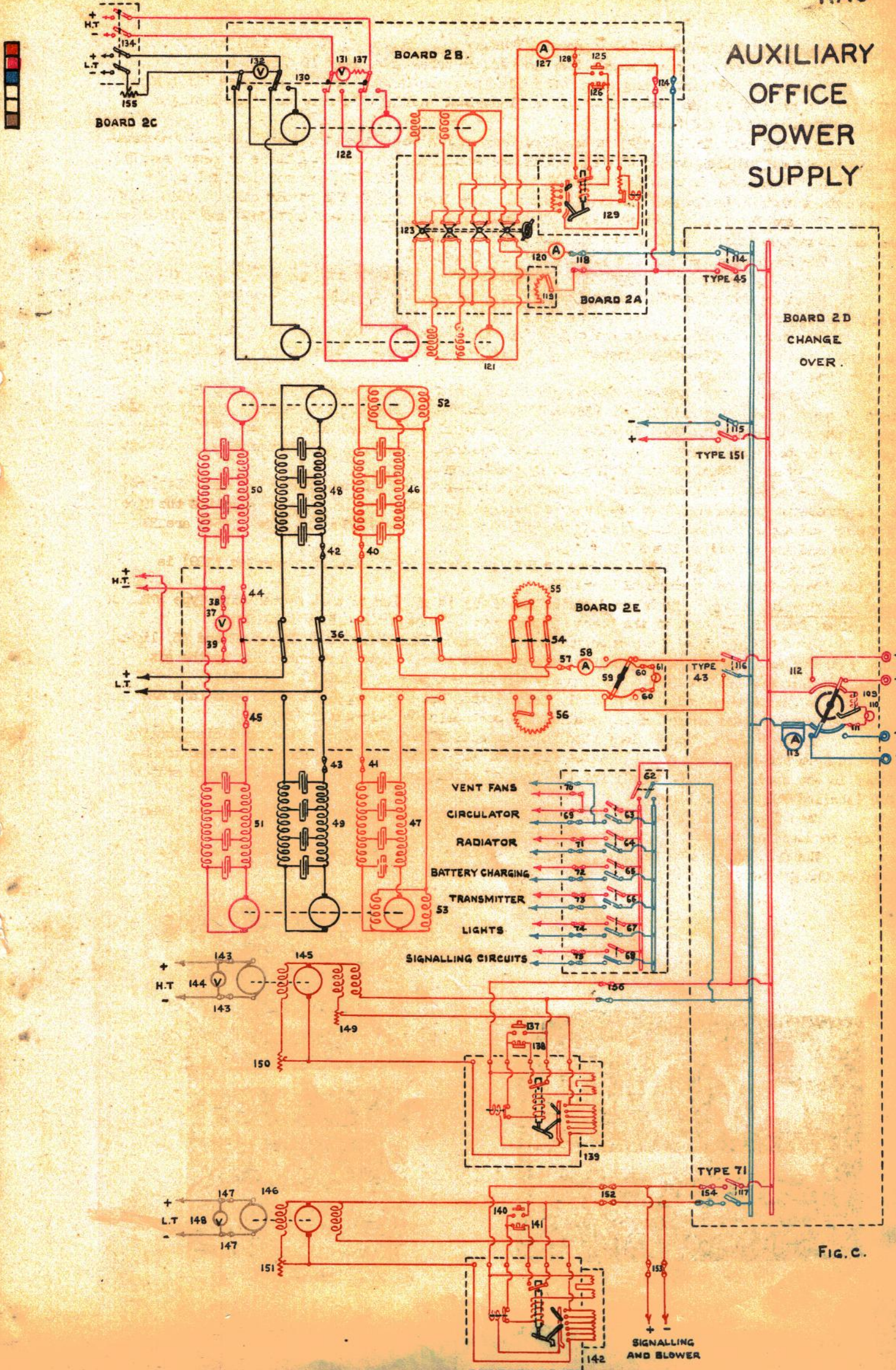

FIG. C.