

UNCLASSIFIED

ACP130(A)

COMMUNICATIONS INSTRUCTIONS SIGNALLING PROCEDURES IN THE VISUAL MEDIUM

ACP 130(A)



July 2005

I
UNCLASSIFIED

FOREWORD

1. The Combined Communications -Electronics Board (CCEB) is comprised of the five member nations, Australia, Canada, New Zealand, United Kingdom and United States and is the Sponsoring Authority for all Allied Communications Publications (ACPs). ACPs are raised and issued under common agreement between the member nations.
2. ACP130(A), COMMON INSTRUCTIONS SIGNALLING PROCEDURE IN THE VISUAL MEDIUM, is an UNCLASSIFIED CCEB publication.
3. This publication contains Allied military information for official purposes only.
4. It is permitted to copy or make extracts from this publication.
5. This ACP is to be maintained and amended in accordance with the provisions of the current version of ACP198.

**THE COMBINED COMMUNICATION-ELECTRONICS BOARD
LETTER OF PROMULGATION
FOR ACP130(A)**

1. The purpose of this Combined Communication Electronics Board (CCEB) Letter of Promulgation is to implement ACP130(A) within the Armed Forces of the CCEB Nations. ACP130(A) COMMUNICATIONS INSTRUCTIONS SIGNALLING PROCEDURES IN THE VISUAL MEDIUM, is an UNCLASSIFIED publication developed for Allied use and, under the direction of the CCEB Principals. It is promulgated for guidance, information, and use by the Armed Forces and other users of military communications facilities.
2. ACP130(A) is effective on 18 July 2005 for CCEB Nations and when by the NATO Military Committee (NAMILCOM) for NATO nations and Strategic Commands.

EFFECTIVE STATUS

Publication	Effective for	Date	Authority
ACP130(A)	CCEB	15 July 05	LOP

3. All proposed amendments to the publication are to be forwarded to the national coordinating authorities of the CCEB or NAMILCOM.

For the CCEB Principals

W. J. Quennell
Squadron Leader, RNZAF
Permanent Secretary to CCEB
1 July 2005

RECORD OF MESSAGE CORRECTIONS

Identification of Message Correction and date, time group		Date Entered	By whom entered
DTG	Correction		

TABLE OF CONTENTS

CHAPTER 1

SECTION I - GENERAL

<u>PARA</u>	<u>SUBJECT</u>	<u>PAGE</u>
 Title	Title
	Page	I
	Foreword	II
	Letter of Promulgation.....	III
	Record of Message Corrections	IV
	Table of Contents	V to XII
101	Purpose	1-1
102	Visual Operators.....	1-1
103	Basis	1-2
104	Use	1-2
105	International Morse Code	1-3
106	The Semaphore Characters.....	1-4
107	Allied Naval Signal Flags and Pennants.....	1-4
Fig 1-1	Semaphore Characters.....	1-5
Fig 1-2	Alphabetical and Numeral Flags	1-7
Fig 1-3	Numeral Pennants, Special Flags and Pennants, Substitutes.....	1-9

SECTION II - MESSAGE FORMS

108	General.....	1-11
109	Plaindress	1-11
110	Abbreviated Plaindress	1-11
111	Codress Message	1-11
112	Service Message.....	1-11
113	Abbreviated Service Message.....	1-12
114	Classification of Service and Abbreviated Service Messages	1-12

SECTION III - SCHEMATIC DIAGRAM

115	General.....	1-13
-----	--------------	------

116	Diagram.....	1-13
117	Explanation.....	1-15

CHAPTER 2

VISUAL CALL SIGNS

SECTION I - GENERAL INSTRUCTIONS

201	Definitions.....	2-1
202	Nature of Visual Call Signs.....	2-1
203	Uses of Visual Call Signs.....	2-1
204	Restrictions on Use of Visual Call Signs.....	2-1
205	Other Call Signs Which May be Used For Visual Communications.....	2-2
206	Transmission of Visual Call Signs.....	2-2
207	Flags and Pennants Used.....	2-3
208	Construction of Message Headings.....	2-3

SECTION II - INDIVIDUAL SHIP CALLS

209	International Call Signs (Signal Letters.....)	2-3
210	Visual Calls and Shortened Visual Calls.....	2-4

SECTION III - MISCELLANEOUS ORGANIZATIONS AFLOAT

211	Unit Indicator Call Signs.....	2-4
212	Numeral Pennant Call Signs.....	2-5
213	Convoy Visual Call Signs.....	2-7
214	Special Task Organization Call Signs (Flaghoist Only).....	2-7

SECTION IV - SINGLE LETTER TYPE INDICATORS

215	Single Letter Type Indicators.....	2-8
216	Single Letter Type Indicators.....	2-8

SECTION V - SHORE SIGNAL STATIONS

217	Government Signal Stations.....	2-9
218	Shore Signal Stations (Commercial.....)	2-9
219	Signal Stations (Military.....)	2-9

SECTION VI - SHIPS' BOATS

220 Boat Call Assignments 2-10

CHAPTER 3OPERATING SIGNALS AND PROSIGNS

SECTION I - GENERAL

301	Operating Signals	3-1
302	Procedure Sign (Prosign)	3-1
303	List of Prosigns	3-1

SECTION II - DESCRIPTION AND USE OF PROSIGNS

304	<u>AA</u> "Unknown Station" (flashing light only)	3-2
305	<u>AA</u> "All After....."	3-2
306	<u>AB</u> "All Before....."	3-2
307	<u>AR</u> End of Transmission.....	3-2
308	<u>AS</u> "Wait"	3-3
309	<u>B</u> "More to Follow"	3-3
310	<u>BT</u> "Long Break"	3-4
311	<u>C</u> "Correct....."	3-4
312	<u>D</u> "Reduce Brilliancy or Use Smaller Light" (flashing light only)	3-4
313	<u>DE</u> "From....."	3-5
314	<u>EEEEEEEE</u> "Errors....."	3-5
315	<u>F</u> "Do Not Answer"	3-5
316	<u>FM</u> "Originator's Sign"	3-5
317	<u>G</u> "Repeat Back....."	3-5
318	<u>GR</u> (Numerals) "Group Count....."	3-7
319	<u>GRNC</u> "Groups Not Counted....."	3-7
320	<u>HM</u> (Transmitted Three Times) "Emergency Silence Sign....."	3-7
321	<u>II</u> Separative Sign	3-9
322	<u>IMI</u> "Repeat"	3-9
323	<u>INFO</u> "Information Addressee Sign....."	3-10
324	<u>INT</u> "Interrogatory....."	3-10
325	<u>IX</u> "Execute to Follow....."	3-11
326	<u>IX=s</u> (5 second flash) "Executive Signal....."	3-11
327	<u>J</u> "Verify with Originator and Repeat....."	3-11
328	<u>K</u> "Invitation to Transmit"	3-11
329	<u>L</u> "Relay" or "Relayed" (flashing light and semaphore only)	3-11
330	<u>NEGAT</u> "Exempted Addressee Sign. (flaghoist only)"	3-12
331	<u>O</u> "Immediate"	3-12
332	<u>P</u> "Priority....."	3-12
333	<u>R</u> "Routine....."	3-12

334 R "Received..... 3-12

335 T "Transmit To..... 3-13

336 T in Codress Messages 3-14

337 TO "Action Addressee Sign..... 3-15

338 W "Information Addressee Sign" (flaghoist only)..... 3-15

339 W "Light Unreadable" (flashing light only..... 3-15

340 WA "Word After 3-15

341 WB "Word Before..... 3-15

342 XMT "Exempted Addressee Sign..... 3-15

343 AX Break In..... 3-16

344 Z "Flash..... 3-16

CHAPTER 4

VISUAL PROCEDURE

SECTION I - GENERAL

401 Transmitting Techniques and Transmitting Speeds..... 4-1

402 Logs and Files 4-1

403 Call Signs 4-1

404 Message Transmission..... 4-2

SECTION II - USE OF PRECEDENCE PROSIGNS

405 Responsibility..... 4-2

406 Significance..... 4-2

407 Precedence Designations and Communication Handling 4-2

408 Indicating Precedence in Preliminary Call..... 4-3

409 Single Precedence..... 4-3

410 Dual Precedence..... 4-3

SECTION III - GROUP COUNT

411 Rules for Counting Groups 4-3

412 Plain Language Texts 4-4

413 Checking Group Count 4-4

SECTION IV - MESSAGE ADDRESS

414 Use of Prosigns FM, TO and INFO..... 4-5
415 Call Serving as Address 4-6
416 Readdressing Messages 4-7

**SECTION V - IDENTIFICATIONS, CORRECTIONS, REPETITIONS,
VERIFICATIONS, CANCELLATIONS, ACKNOWLEDGEMENTS**

417 Identification of Messages 4-7
418 Corrections and Repetitions 4-8
419 Examples of Repetitions 4-9
420 Verifications 4-13
421 Examples of Verifications 4-13
422 Acknowledgements..... 4-15
423 Examples of Acknowledgements..... 4-15
424 Duplicate or Suspected Duplicate Messages 4-16
425 Cancellations 4-16

SECTION VI - RULES FOR REFILEING MESSAGES

426 Messages in Basic Format..... 4-16

CHAPTER 5

VISUAL RELAY RESPONSIBILITY

501 General..... 5-1
502 Chain of Visual Responsibility..... 5-1
503 Chain of Visual Responsibility - Directional Method..... 5-1
504 Repeating Ships 5-2

CHAPTER 6

FLASHING LIGHT

601 Procedures 6-1
602 Directional Procedure 6-2
603 Non-Directional Procedure..... 6-3
604 Calling..... 6-4
605 Answering and Receipting 6-5
606 Relaying Instructions 6-6
607 Special Procedures..... 6-6
608 Indicating Precedence in Calls 6-12

609	Transmission of Signals from a Signal Book.....	6-12
610	Receiving Station Repeating Difficult Words	6-13
611	Executive Method	6-13
612	Examples of Delayed Executive Method - Directional Procedure	6-15
613	Example of Delayed Executive Method - Non-Directional Procedure.....	6-16
614	Immediate Executive Method	6-16
615	Example of Immediate Executive Method.....	6-17
616	Example of Verification and Correction -Executive Method Messages.	6-18
617	Canceling Messages.....	6-20
618	Flashing with Aircraft	6-21

CHAPTER 7

SEMAPHORE

701	General.....	7-1
702	Transmitting.....	7-1
703	Rate of Signaling.....	7-1
704	Reading	7-1
705	Signalling Prosigns and Operating Signals.....	7-1
706	Numerals	7-2
707	Transmission of Signals from a Signal Book.....	7-2
708	Special Characters.....	7-2
709	Special Semaphore Abbreviations	7-4
710	Calling.....	7-4
711	Repetitions.....	7-5
712	Interruption of Transmission or Reception.....	7-5
713	Receipting.....	7-5
714	Executive method by Semaphore.....	7-5
715	Relay.....	7-5
716	Examples	7-6

CHAPTER 8

FLAGHOIST

801	Flags and Pennants	8-1
802	Call Signs, Address Groups and Sequence Numbers	8-1
803	Message Construction.....	8-1
804	The Heading	8-1
805	Omission of Address.....	8-1
806	Modification of Heading.....	8-2
807	Construction of Heading.....	8-2

808	Text.....	8-3
809	Use of Tackline (TACK.....	8-3
810	Hoisting Flag Signals	8-3
811	Order of Reading Flag Signals.....	8-5
812	Answering and Acknowledging Flag Signals	8-5
813	Executing Flag Signals.....	8-6
814	Canceling a Signal.....	8-6
815	Correcting a Signal.....	8-7
816	Emergency Alarm Signals	8-7
817	Expediting of Flaghoist Signaling.....	8-7
818	Relaying.....	8-7
819	Entering and Leaving Port	8-9
820	Speed Flags	8-9
821	Shifting Berths.....	8-10

CHAPTER 9

MISCELLANEOUS SYSTEMS

SECTION I - SOUND

901	Distress	9-1
902	Whistles, Sirens, Bells, etc.....	9-1
903	Limitations	9-1
904	Form of Message	9-1
905	Receipting.....	9-2
906	The Executive Signal.....	9-2
907	Identification of Ships.....	9-3

SECTION II - INFRA-RED COMMUNICATION

908	General.....	9-4
909	Basic Forms	9-4
910	Interference	9-4
911	Guardships	9-4
912	Indicating Traffic for Stations	9-4
913	Calling Periods.....	9-4
914	Point of Train Light (POT)	9-5
915	Procedure.....	9-5
916	Navigational Aids.....	9-5
917	Uses of Infra-Red in Amphibious Operations	9-5

CHAPTER 10**PANEL SIGNALLING****SECTION I - INTRODUCTION**

1001	General.....	10-1
1002	Position Marking.....	10-1
1003	Composition of Position Marking Panels.....	10-1
1004	Request for Position Markings.....	10-1
1005	Signalling	10-2
1006	Description of Signalling Panels	10-2
1007	Visibility of Signalling Panels	10-2
1008	Signalling Panel Code.....	10-2
1009	Indicators	10-3
1010	Sending Numbers	10-3
1011	Sending Letters	10-8
1012	Operating Procedure.....	10-13
1013	Spacing	10-13
1014	Signalling and Acknowledgment Receipt.....	10-13

SECTION II - SPECIAL SIGNS

1015	General.....	10-14
1016	Direction of Landing.....	10-14
1017	Direction Indicator.....	10-14
1018	Pick Up Message Here	10-15
1019	Drop Message Here	10-15
1020	Message Drop Not Recovered	10-15
1021	Crossed Panels	10-16

SECTION III - MARKING OF DROPPING ZONES

1022	Types of Visual Marking.....	10-16
1023	Code Identifiers	10-16
1024	Marking of Dropping Zones.....	10-16
1025	Emergency Marking.....	10-17
1026	Unmarked Dropping Zones.....	10-17

SECTION IV - MARKING OF LANDING SITES AND STRIPS

1027 General..... 10-17
1028 Types of Visual Marking..... 10-17
1029 Marking of Landing Strips 10-18
1030 Marking of Helicopter Landing Sites..... 10-18

SECTION V - IDENTIFICATION

1031 General..... 10-19
1032 Identification of Dropping..... 10-19
1033 Identification of Ground Forces 10-19

SECTION VI - VOCABULARY

1034 Main Combat Messages 10-20
1035 Intelligence on Friendly Action..... 10-20
1036 Procedural Signals 10-20
1037 Liaison..... 10-21
1038 Artillery Observation..... 10-21
1039 General..... 10-21
1040 Special Requests..... 10-21
1041 Intelligence on Enemy Action..... 10-22
1042 Instructions for Aircraft 10-22
1043 Instructions for Helicopters..... 10-22

SECTION VII - EMERGENCY SIGNALS

1044 Ground/Air Visual Signals for use in Emergency by Survivors 10-23
1045 Ground/Air Visual Signals for use in Emergency by Search Parties 10-23
1046 Ground/Air Visual Signals for use in Emergency
Use in Military Operations 10-24
Fig 10-1 Visual Markings of DZ by Day..... 10-26
Fig 10-2 Visual Markings of DZ by Night..... 10-27
Fig 10-3 Visual Marking of Landing Strips by Day..... 10-28
Fig 10-4 Visual Marking of Landing Strips by Day - Multiple Aircraft 10-29
Fig 10-5 Visual Marking of Helicopter Landing Site by Day 10-30
Fig 10-6 Visual Marking of Helicopter Landing Site by Night..... 10-31
Fig 10-7 Panel Code - Figures 10-32
Fig 10-8 Panel Code - Letters..... 10-33

CHAPTER 11

PYROTECHNICS

SECTION I - INTRODUCTION

1101 Purpose and Scope..... 11-1
1102 Definitions 11-1
1103 Limitations 11-1
1104 Night or Day Usage 11-2
Fig 11-1 RED..... 11-3
Fig 11-2 GREEN 11-4
Fig 11-3 WHITE (or YELLOW) 11-6
Fig 11-4 Miscellaneous Combination Lights 11-8
Fig 11-5 Pyrotechnic Smoke..... 11-9
Fig 11-6 Very Flare Identification..... 11-11

UNCLASSIFIED

ACP130(A)

VI
UNCLASSIFIED

Original

CHAPTER 1

INTRODUCTION

SECTION 1 - GENERAL

101. PURPOSE

The procedures prescribed herein are designed to provide a concise and definite language whereby visual communications in all mediums may be conducted accurately and rapidly.

102. VISUAL OPERATORS

- a. The attainment of reliability, speed and security depends to a large extent upon the operator. It is essential that he be well trained in the maintenance of Signalling discipline and in the nature of his responsibilities.
- b. Adherence to prescribed procedure is mandatory. Unauthorized departures from or variations in prescribed procedure invariably create confusion, reduce reliability and speed, and tend to nullify security precautions, and are therefore prohibited. If the procedure prescribed herein does not cover a specific operating requirement, resorting to initiative and common sense should suffice.
- c. The following basic rules are essential to transmission discipline and security and shall be strictly enforced in all visual communications.
 - (1) No transmission shall be made which has not been authorized by proper authority.
 - (2) An immediate answer to a call is essential.
 - (3) The following practices are specifically forbidden:
 - (a) Violations of visual silence.
 - (b) Unofficial conversation between operators.
 - (c) Transmitting the operator's personal sign.
 - (d) Unauthorized use of plain language.
 - (e) Use of other than authorized prosigns.
 - (f) Unauthorized use of plain language in place of applicable prosigns or operating signals.

- (g) Linkage or compromise of classified call signs and address groups by plain language disclosures or association with unclassified call signs.
- (h) Profane, indecent or obscene language.
- (4) The following practices are to be avoided:
 - (a) Use of excessive beam width or of a light larger or brighter than necessary.
 - (b) Transmitting at speeds beyond the capabilities of receiving operators.

103. **BASIS**

- a. The visual procedure contained herein incorporates the basic message format. Chapters 1 through 4 contain, for the most part, standard communication procedures peculiar to flashing light, semaphore and flaghoist. In using the examples given in the first four chapters, care must be taken to apply to them the procedure applicable to the particular visual method in mind.
- b. Call signs used in this publication are to be considered fictitious.
- c. The examples show normal flashing light procedure.
- d. In examples, where a definite time lag occurs between transmission and indication of receipt where appropriate, (e.g., by a flash), the receiving ship's transmission is printed one line below that of the transmitting ship. Where there is no appreciable time lag (e.g., when all stations are repeating the "executive signal") all transmissions are shown on the same line.

104. **USE**

- a. The visual procedures prescribed herein shall be used for all transmissions in military visual communications.
- b. When messages in commercial form are handled by military systems, the procedure contained herein shall be used in the calling and routing instructions.
- c. When communicating with non-military ships or stations or non-allied warships, international procedure will be used. This procedure is contained in the International Code of Signals.
- d. Groups from the International Code of Signals may be used alone or in conjunction with groups from the Allied Maritime Tactical Signal Book or national or regional defense organization publications. Whenever international groups are used alone, international procedure is to be used in answering.

- (1) Whenever military use is made of the International Code of Signals, groups will be preceded by the code pennant when used with flags, and by the proword INTERCO when transmitted by morse, semaphore or spoken.
- (a) Whenever international signals are used alone, CODE followed by TACK shall be used to indicate that all groups following are taken from the International Code of Signals. When the signal consists of only one group the TACK may be omitted.
- (b) Whenever signals from the Allied Maritime Tactical Signal Book are supplemented by a group from the International Code of Signals, CODE shall immediately precede the signal group to indicate that only one group is taken from the International Code.
- (c) For flaghoist signalling, a call sign preceding CODE may be hoisted in a superior position on a separate hoist and left flying during succeeding hoists of International Code groups. Hauling down the call and CODE indicates the end of the message.

105. INTERNATIONAL MORSE CODE

- a. All transmissions over military visual systems, except semaphore, flaghoist and panels are made by use of the International Morse Code. The characters used are:

- (1) Letters.

A	.-	J	.-.-	S	...-
B	-...-	K	-.-	T	-
C	-.-.	L	.-..	U	..-
D	-..	M	--	V	...-
E	.	N	-. .	W	.-.-
F	..-.	O	---	X	-.-.
G	--.	P	.-.-	Y	-.--
H	Q	---.	Z	---.
I	..	R	.-.		

- (2) Figures.

1	.----	4-	7	--...	Ø	-----
2	..---	5	8	----.		
3	...--	6	-....	9	----.		

(3) Punctuation.

Colon	---...
Comma	---,---
Hyphen or dash	-....-
Parenthesis/left hand bracket	-.--.
Parenthesis/right hand bracket	-.--.-
Period or decimal point	..--.-
Question mark	..--..
Slant/oblique stroke	-..-.

b. Character Formulations.

- (1) A dot is used as the unit of duration.
- (2) A dash is equal to three units.
- (3) An element is either a dot or a dash.
- (4) The space between elements is one unit.
- (5) The space between characters is three units.
- (6) The space between groups is seven units.
- (7) Overscored characters are transmitted as if they were a single character.

106. **THE SEMAPHORE CHARACTERS**

a. All semaphore transmissions are made by use of:

- (1) International alphabet and special signs, which are shown in Figure 1-1.
- (2) Punctuation signs as follows:

Colon	<u>OS</u>
Comma	<u>MIM</u>
Hyphen or dash	<u>DU</u>
Parenthesis/left hand bracket	<u>KN</u>
Parenthesis/right hand bracket	<u>KK</u>
Period or decimal point	<u>AAA</u>
Question Mark	<u>IMI</u>
Slant/oblique stroke	<u>XE</u>

107. ALLIED NAVAL SIGNAL FLAGS AND PENNANTS

The signal flags and pennants used in flaghoist communications shall be as shown in Figure 1-2.

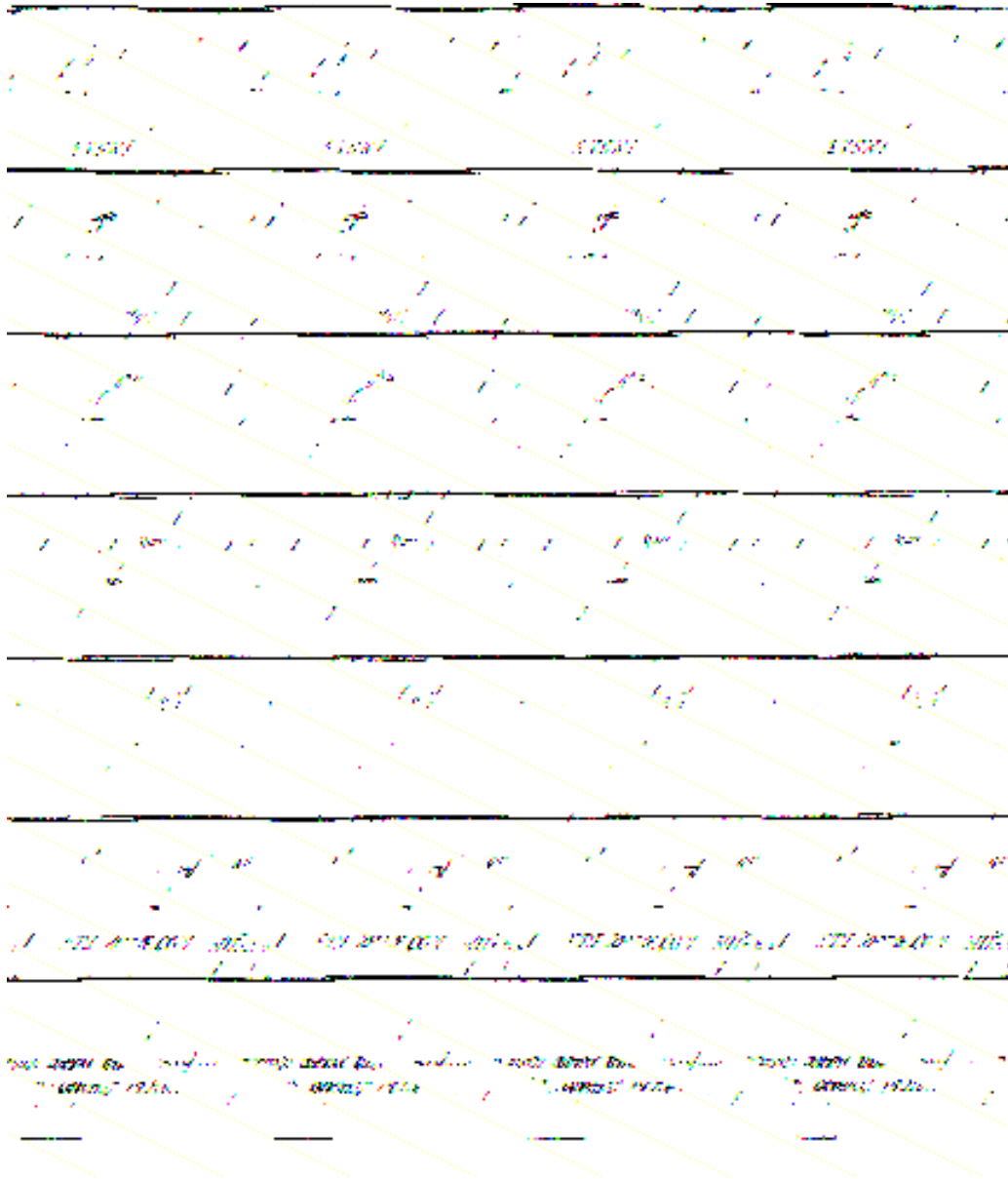

Figure 1-1 Semaphore Characters

UNCLASSIFIED

ACP130(A)

THIS PAGE INTENTIONALLY BLANK

1 - 6

UNCLASSIFIED

ORIGINAL

Figure 1-2 - Alphabetical and Numerical Flags

A		H		O		V	
B		I		P		W	
C		J		Q		X	
D		K		R		Y	
E		L		S		Z	
F		M		T			
G		N		U			
1		2		3		4	
5		6		7		8	
9		0					

UNCLASSIFIED

















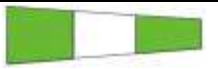





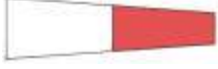







ACP130(A)

THIS PAGE INTENTIONALLY BLANK

1 - 8
UNCLASSIFIED

ORIGINAL

Figure 1-3 Numerical Pennants Special Flags and Pennants, Substitutes

ANS/CODE		SCREEN		1st	
CORPEN		SPEED		2nd	
DESIG		STBD		3rd	
EMERG		STATION		4th	
FORM		TURN			
INT		SQUAD			
NEGAT		FLOT			
PREP		DIV			
CHURCH		SUB DIV			
PORT					
1		6			
2		7			
3		8			
4		9			
5		0			

UNCLASSIFIED

ACP130(A)

THIS PAGE INTENTIONALLY BLANK

1 - 10
UNCLASSIFIED

ORIGINAL

SECTION II - MESSAGE FORMS

108. **GENERAL**

Messages for transmission in military visual communications shall be prepared in plaindress, abbreviated plaindress or codress form.

109. **PLAINDRESS**

- a. A plaindress message is one in which the originator and addressee designations are indicated externally of the text.
- b. A plaindress message contains all the components (unless the call serves as the address) as shown in the basic message format, except that the prefix may be omitted. It must always include the precedence and date-time group.

110. **ABBREVIATED PLAINDRESS**

- a. Operational requirements for speed of handling may require abbreviation of plaindress message headings. In such case any or all of the following may be omitted:
 - (1) Precedence.
 - (2) Date.
 - (3) Date-time group with the year expressed in four digits. (If a date time group is not used, a time group should appear in Format Line 14) within the body of a message, the established standards for character based messaging will be followed, e.g. The United States Message Text Formats (USMTFS), Allied Data Publication - 3 (ADATP-3), Australian Defence Formatted Message Standard (ADFORMS). These standards have adopted a four digit year for data transmission.
 - (4) Group count (except for encrypted messages).

111. **CODRESS MESSAGE**

A codress message is one in which the entire address, i.e., originator and all addressees, except when address indicating groups are used, is encrypted within the text. The heading of such a message contains only information necessary to enable communication personnel to handle it properly. It contains all other components shown in the schematic diagram in Section III.

112. SERVICE MESSAGE

- a. A service message is one between communication personnel pertaining to any phase of traffic handling, communication facilities, or circuit conditions.
- b. An encrypted service message will always carry a numerical group count and will be identified as a service message only within the encrypted text.
- c. Plain language service messages are identified by the abbreviation SVC as the first word of the text following any security classification.
- d. Service messages are prepared and transmitted in plaindress, abbreviated plaindress or codress form. They generally concern messages originated at, destined for, or refiled by, that station and normally will be assigned a precedence equal to that of the message to which they refer.

113. ABBREVIATED SERVICE MESSAGE

- a. An abbreviated service message is one in which the text contains only prosigns, operating signals, address designations, identification of messages, parts of messages and amplifying data as necessary. It may be originated by operators, and may contain any of the components shown in the Basic Message Format except that:
 - (1) The long break is used only if the date time group/time group is used.
 - (2) The date time group/time group is to be employed only when it is necessary to indicate the time at which the message was originated or when it is considered that further reference may be made to the message.

114. CLASSIFICATION OF SERVICE AND ABBREVIATED SERVICE MESSAGES

- a. An unclassified service or abbreviated service message may be used when referring to a message classified RESTRICTED or above if only operating signals, prosigns and message or transmission identifications are used. If it is necessary to include anything that would reveal part of the text of the classified message, however, the service or abbreviated service message must be classified.
- b. An unclassified service or abbreviated service message referring to a message received in codress format or using encrypted call signs or address groups shall use only those message or transmission identifications which were contained in the external message heading received.

SECTION III - SCHEMATIC DIAGRAM

115. GENERAL

- a. Each message prepared in either plaindress, abbreviated codress or codress will have three "PARTS".
 - (1) Heading.
 - (2) Text.
 - (3) Ending.

- b. Each message "PART" has certain "COMPONENTS" which are broken down into "ELEMENTS" and "CONTENTS".
 - (1) Each message "PART" and a majority of the "COMPONENTS" and "ELEMENTS" have a standardized arrangement or sequential order of appearance.
 - (2) In the schematic diagram, format lines 2, 3, 4, 14, 15 and 16 identify the procedural portions of the basic message format as designed for visual communications. Lines 5 through 13 are the non-changeable elements of the basic message format. All format lines do not necessarily appear in every message, however, when used, they will be in the order indicated. (See paragraph 116.)

116. DIAGRAM

In the following diagram it should be noted that every "ELEMENT" is indicated in the order of appearance in the message. All "ELEMENTS" may not be required. The contents of the various elements are not necessarily indicated as they will appear.

Parts	Components	Elements	Format Line	Contents
H			1	Not Used
E	Procedure (Note1)	Call	2	Prosign F (see paragraph 315), stations called (Prosign XMT, exempted calls) Prosign DE and station calling
A		Transmission Identification	3	Station serial number

UNCLASSIFIED

ACP130(A)

Parts	Components	Elements	Format Line	Contents
D		Transmission Instructions	4	Prosign F, G, T, L; Operating signals; call signs, address groups, plain language address designators.
I	Preamble	Precedence	5	Precedence Prosigns
N		Date-time group		Date and time expressed in digits, and zone suffix followed by month indicated by the first three letters, and if required by national authorities, the year indicated by the last two digits.
G		Message Instructions		Operating signals; Prosign IX
	Address (Note 2)	Originator's sign	6	Prosign FM
H		Originator		Originator's designation (call sign, address group, plain language address designator)
E		Action addressee sign	7	Prosign TO
A		Action addressees		Action addressees' designations (call signs, address groups, plain language address designators)
D		Information addressee sign	8	Prosign INFO
I		Information addressees		Information addressees' designations (call sign, address group, plain language address designators)
N		Exempted addressee sign	9	Prosign XMT
G		Exempted addressees		Exempted addressees' designations (call sign, address group, plain language address designators)

Parts	Components	Elements	Format Line	Contents
	Prefix	Accounting Information	10	Accounting symbol
		Group Count		Prosign GR (numerals) or GRNC
		Separation	11	Prosign \overline{BT}
T E X T	Text	Subject Matter	12	Security Classification or UNCLAS as appropriate when required; the abbreviation SVC; internal instructions; thoughts or ideas as expressed by the originator.
		Separation	13	Prosign \overline{BT}
E N	Procedure	Time group	14	Hours and minutes expressed in digits, and zone suffix.
D I N G		Final Instructions	15	Prosigns \overline{AS} B, C, G, IMI, GR (numerals), IX (5 second flash), operating signals.
		Ending sign	16	Prosign K or \overline{AR}

NOTE 1: Plain language address designators shall not be used in any component of codress messages.

2: The address component is prohibited with codress procedure.

117. EXPLANATION

- a. Line 2 - This line will contain, as required, the call signs/address groups of the stations called; the prosign XMT, exempted call signs/address groups, the prosign DE and the call sign/address group of the calling station. It may be preceded by the prosign F, made four times.
- b. Line 3 - Not normally used in visual signalling except in messages being relayed.
- c. Line 4 - This line may contain the prosigns F, G, L and T; operating signals, call signs, address groups, or plain language address designators.

- d. Line 5 - This line will contain the appropriate precedence prosigns (in the case of dual precedence, both prosigns will be shown), the originator's date-time-group, message instructions in the form of operating signals and the prosign IX as necessary.
- e. Line 6 - This line is identified by the appearance of the prosign FM and contains the designation of the originator, which may be indicated by a call sign, address group or plain language address designator.
- f. Line 7 - This line is identified by the prosign TO and contains the designation of the action addressees in the form of call signs, address groups, or plain language address designators.
- g. Line 8 - This line is identified by the prosign INFO and contains the designation of the information addressees in the form of call signs, address groups, or plain language address designators.
- h. Line 9 - This line is identified by the prosign XMT and contains the designation of the addressees who are exempted from the collective designation when such designation is used in format line 7 and 8.
- i. Line 10 - This line may contain accounting symbols (as required), the group count prosign and numerals and the groups not counted prosign. Encrypted messages will always indicate a numerical group count.
- j. Line 11 - This line contains the prosign BT, which separates the heading from the text.
- k. Line 12 - This is the text of the message and may contain internal instructions as well as the subject matter expressed by the originator. It may be preceded by the security classification or UNCLAS as appropriate and the abbreviation SVC.
- l. Line 13 - This line contains the prosign BT, which separates the text from the message ending.
- m. Line 14 - This line, when used, will contain the time group expressed in hours and minutes plus the zone suffix. All messages other than those transmitted by the Executive method (IX/RIX) should contain a line 14 time group. This includes non-executive messages of the Formal, SVC and abbreviated SVC formats including CANCELLATIONS, VERIFICATIONS, REPETITIONS and CORRECTIONS.
- n. Line 15 - This line is identified by the appearance of the prosigns AS, B, C, G, GR (numerals), IMI, IX (5 second flash), operating signals and station designations as required.

- o. Line 16 - This line is identified by the appearance of the prosign K or AR [—]very transmission must end with the prosign K or AR as appropriate, except as noted in paragraph 605.f.

CHAPTER 2

VISUAL CALL SIGNS

SECTION I - GENERAL INSTRUCTIONS

201. DEFINITIONS

- a. Address Group - A group of four letters, or letters and numerals, assigned to represent command(s), authority(ies), activity(ies), unit(s), or geographic location(s); used primarily for the addressing of communications, but may be used as a call sign for establishing and maintaining communications.
- b. Call Sign - Any combination of characters or pronounceable word(s) which identifies a communication facility(ies), command(s), authority(ies), activity(ies), unit(s); used primarily for establishing and maintaining communications.
- c. Visual Call Sign - A call sign provided primarily for visual signalling.

202. NATURE OF VISUAL CALL SIGNS

Visual call signs are shorter than the other call signs or address groups assigned to an organization. This advantage is highly significant in determining the length of a flaghoist, and is also useful in reducing the transmission time of messages by other visual means.

203. USES OF VISUAL CALL SIGNS

- a. Visual call signs contained herein may be used:
 - (1) To establish visual communications between organizations.
 - (2) In the transmission instructions and address of a message which will be transmitted solely by visual means. (See paragraph 204.b.)
 - (3) For transmitting groups from authorized signal books, visual call signs are used:
 - (a) To address ships, units or commands, in which case they precede the signal.
 - (b) To complete, amplify, or vary the meaning of a signal, in which case they are used in conjunction with the signal concerned.
 - (c) To denote or indicate ships, units or commands in which case they follow the signal.

204. RESTRICTIONS ON USE OF VISUAL CALL SIGNS

- a. Collective Call Signs - When employed, collective call signs contained herein:
 - (a) Apply only to ships present.
 - (b) Include the commander of any organization or group and all subordinate commanders therein.
- b. Visual Call Signs - Will not be used in the transmission instructions or address of message to be transmitted or relayed by other than visual means.
- c. Reference Table:

Means of Transmission	Method	Call	Address	Text
Visual Means	Flaghoist	Yes	**	Yes
	Flashing Light	Yes	Yes	No*
	Semaphore	Yes	Yes	No*
Other Means	Radiotelephone	No	No	No*
	Radiotelegraph	No	No	No*

- * Visual Call Signs may be used when text consists of signal groups.
- ** Call serves as the address in flaghoist.

205. OTHER CALL SIGNS WHICH MAY BE USED FOR VISUAL COMMUNICATIONS

- a. In addition to the call signs contained in this publication, the following call signs are authorized for use in visual communications:
 - (1) Radio Call Signs (except Radiotelephone).
 - (2) International Call Signs (Signal letters).
 - (3) Tactical Call Signs.
 - (4) Collective Call Signs.
 - (5) Indefinite Call Signs.
 - (6) Task organization Call Signs.
 - (7) Plain Language Addresses.

- b. Address Groups may be used as call signs by Coast Guard and Navy commands (except in non-military communications).

206. **TRANSMISSION OF VISUAL CALL SIGNS**

- a. In constructing visual calls to be transmitted by flaghoist, numerals are expressed by numeral pennants, except when numeral flags are specifically indicated (see paragraph 214). Numerals appearing in visual call signs transmitted by any visual means other than flaghoist represent numeral pennants, and are written as p1, p2, p6, p7, etc., to distinguish them from numeral flags.
- b. By any visual means other than flaghoist, call signs are transmitted using their Morse or semaphore equivalents. All call signs (except Radiotelephone call signs) in the text of signals from an authorized signal book, are preceded by the prosign PT transmitted as a Morse symbol or semaphore equivalent meaning "Call Sign Follows." If more than one such call sign is included in the text, each will be preceded by PT.

EXAMPLES: (Text of signals)

1. Call sign of Cruiser 46 is transmitted as.....PT $\overline{C46}$
2. Call signs of Cruisers 46 and 47 are transmitted as.....PT $\overline{C46}$ PT $\overline{C47}$

- c. Call signs in the text of signals may be spelled out when conditions make this advisable. Call signs spelled out are to be preceded by "PT" as in b. above.

EXAMPLE:

Call sign of Cruiser 46 is transmitted "PT $\overline{C46}$ Charlie Four Six."

207. **FLAGS AND PENNANTS USED**

- a. Non-military signal stations and ships use the International flags and pennants for flaghoist signalling.
- b. Naval ships and naval visual signal stations use the naval special flags and pennants in addition to the International flags and pennants. (See ATP 1, Vol. II and Plate II)

208. **CONSTRUCTION OF MESSAGE HEADINGS**

- a. Information required for the construction of visual headings is found in Chapters 1 and 8.
- b. Particular attention should be given to:

DIV	DIVISION
SQUAD	SQUADRON
GROUP/FLOT	GRUP/FLOTILLA
EXAMPLE:	DIV . . . Division

(2)	SUBDIV	SUBDIVISION	
Type	DIV	Numeral.....Type	DIVISION.....Number
Indicator	SQUAD Pennants		SQUADRON
	GROUP/FLOT		GROUP/FLOTILLA
EXAMPLE:	R DIV p4		Carrier Division 4D
	GROUP/FLOT pl		Destroyer Group/Flotilla 1

(2) In the preceding example the type indicator may be omitted if no confusion will arise.

EXAMPLE: D DIV p2p2 may be signalled as DIV p2p2.

- b. Other publications provide address groups for division, squadron, and group/flotilla organizations. These address groups will be used when confusion as to unit called will arise, i.e., LST DIVISION 11, and LSU DIVISION 11, visual call sign L DIV plpl, operating within visual communication range of each other.
- c. Visual Commander Call Signs

To form the visual call sign of the commander of an organized Group/Flotilla, Squadron, Division or Sub-Division of ships the unit indicator of the unit is preceded by pennant zero.

EXAMPLES:

p0 SQUAD D	Commander this Destroyer Squadron
p0DIV R	Commander this Carrier Division
p0GROUP/FLOT Dp2	Commander Destroyer Group/Flotilla 2
p0GROUP/FLOT CDp9	Commander Cruiser Destroyer Group/Flotilla 9

- d. The call sign for a group of ships associated with an individual ship that is not organized as a Task Unit or element is constructed by prefixing Sub Div to the call sign of the identifying ship. The command call is constructed by prefixing the ship's call to Sub Div.

EXAMPLES:

SUBDIV RpØp5	HMS EAGLE Sub Division
SUBDIV Rplp4	USS TICONDEROGA Sub Division
Rplp4 SUBDIV	Commander TICONDEROGA Sub Division

212. NUMERAL PENNANT CALL SIGNS

- a. These visual call signs may be used alone or followed by the type indicator and/or unit indicator.
- b. To form commander visual call signs, the below listed collective visual call signs are preceded by pØ.
- c. The collective visual call sign of the command includes the commander thereof and all subordinate commanders therein.

CALL SIGN	MEANING	CALL SIGN	MEANING
pØ	(Singly) My Immediate Superior in Tactical Command	p4p9	**
pØ	Commanders of (Type and/or pennant(s) following)	p5pØ	**
pØpØ	Commanders Under My Command	p5p1	Entering/Leaving Harbour Group No 1
pØp1	Officers in Tactical Command	p5p2	Entering/Leaving Harbour Group No 2
p1	All Ships Under My Tactical Command	p5p3	Entering/Leaving Harbour Group No 3
p2	All Ships	p5p4	
p3	Main Body	p5p5	Escort Force Group

UNCLASSIFIED

ACP130(A)

CALL SIGN	MEANING	CALL SIGN	MEANING
p4	This Line	p5p6	Fire Support Group (Unit)
p5	Screen	p5p7	Flank Groups (Both Flanks)
p6	This Task Force	p5p8	Flank Groups (Left)
p7	This Task Group	p5p9	Flank Groups (Right)
p8	This Task Unit	p6pØ	Fueling Units (Oilers)
p9	This Task Element	p6p1	Fueling Group (Ship Fueling)
p1pØ	All Task Force Commanders	p6p2	Hunter/Killer Group
p1p1	All Task Group Commanders	p6p3	Logistics Support Group
p1p2	All Task Element Commanders	p6p4	Minelaying Group
p1p3	**	p6p5	Minesweeping Group
p1p4	**	p6p6	
p1p5	**	p6p7	
p1p6	**	p6p8	Patrol Group
p1p7	**	p6p9	Pickets
p1p8	**	p7pØ	Pouncers
p1p9	**	p7p1	Reconnaissance Group (Unit)
p2pØ	Advance Force (Group)	p7p2	Replenishment Force (Group)
p2p1*	All Units on Circle 1	p7p3	Rescue Destroyer(s)
p2p2*	All Units on Circle 2	p7p4	Reserve Force (Group)
p2p3*	All Units on Circle 3	p7p5	Reserve Replenishment Group (Unit)
p2p4*	All Units on Circle 4	p7p6	Retirement Group
p2p5*	All Units on Circle 5	p7p7	Screening Group
p2p6*	All Units on Circle 6	p7p8	Screening Units under My Command
p2p7*	All Units on Circle 7	p7p9	Scouting Group
p2p8*	All Units on Circle 8	p8pØ	Search and Rescue Group
p2p9*	All Units on Circle 9	p8p1	Service Line (First)
p3pØ	All Units in this Exercise	p8p2	Service Line (Second)
p3p1	All units this column or column indicated by numeral	p8p3	Service Line (Third)
p3p2	Amphibious Force	P8p4	Senior Officer Present Afloat (SOPA)
p3p3	ASW Carrier Group	p8p5	Senior Officer Present Afloat (Admin)
p3p4	ASW Covering Force	p8p6	Striking Force (Group)
p3p5	Attack Force Group	p8p7	Support Force (Group)
p3p6	Battle Line	p8p8	Surface Action Force (Group)
p3p7	Carrier Group	p8p9	Search Attack Unit (SAU)
p3p8	Carriers Sup	p9pØ	Transport Group
p3p9	Carriers and Rescue Destroyers	p9p1	Waiting Line (First)
p4pØ	Center Group	p9p2	Waiting Line (Second)
p4p1	Close Covering Group	p9p3	Waiting Line (Third)
p4p2	Convoy (to indicate or denote)	p9p4	**

UNCLASSIFIED

ACP130(A)

CALL SIGN	MEANING	CALL SIGN	MEANING
p4p3	Demonstration Force Group	p9p5	**
p4p4	Detached Wing	p9p6	**
p4p5	**	p9p7	**
p4p6	**	p9p8	**
p4p7	**	p9p9	**
p4p8	**		

* Units on a partial circle may be indicated by a third pennant.

** For Local Assignment by Task Force Commanders or Higher Authority.

EXAMPLES:

- | | | |
|----|--|----------|
| 1. | All Destroyers Under My Tactical Command | p1D |
| 2. | Division Commanders Under my Command | pØpØ DIV |
| 3. | Commander This Squadron | pØ SQUAD |
| 4. | Cruisers of the Surface Action Group | p8p8C |
| 5. | All Units on Circle 3.5 | p2p3p5 |
| 6. | Commander Minesweeping Group | pØp6p5 |

213. **CONVOY VISUAL CALL SIGNS**

Convoy Visual Call Signs are contained in ATP 2, VOL II or appropriate national or regional defense organization publications.

214. **SPECIAL TASK ORGANIZATION CALL SIGNS (FLAGHOIST ONLY)**

- a. The visual call signs given below may be used in FLAGHOIST communications as short call signs within a task organization. These call signs always begin with a numeral flag followed by numeral pennant(s) which indicate the number of the task organization.
- b. Type indicators may be used following the call sign.
- c. Table of Task Organization visual Call Signs:

<u>CALL SIGN</u>	<u>MEANING</u>
Ø	Commander Task Force No _____
1	*Commander Task Group No _____
2	*Commander Task Unit No _____
3	*Commander Task Element No _____
4	Commander _____ Fleet
5	
6	Task Force No _____
7	*Task Group No _____
8	*Task Unit No. _____
9	*Task Element No. _____

* Within own Task Organization

EXAMPLES:

1. 6p4p5 Task Force 45
2. 8p3 Task Unit 3 (Within own Task Group)
3. 9p2D Destroyers of Task Element 2 (Within own Task Unit)
4. 3p6 Commander Task Element 6 (Within Own Task Unit)

SECTION IV - SINGLE LETTER TYPE INDICATORS

215. SINGLE LETTER TYPE INDICATORS

One or two Letter Type indicators may be used following the One or Two Numeral Pennant Call Signs and the Special Task Organization Numeral Flag Call Signs.

EXAMPLES:

1. p2D All Destroyers
2. 6p4p5D Destroyers of Task Force 45
3. pØCD Commander Cruiser Destroyer

216. SINGLE LETTER TYPE INDICATORS

A list of Single Letter Type Indicators is given below:

- A. Auxiliary (Oiler, Cargo, Tender, Floating Dry Dock, Sloop, etc.)
- B Battleship
- C Cruiser
- D Destroyer/Destroyer Escort
- F Frigate
- G Government Station (See paragraph 217)
- H Visual Signal Station (Military)(See paragraph 219)
- K Shore Signal Station (Commercial)(See paragraph 218) Miscellaneous Fleet units (NATO use only)
- L Assault Vessel (Landing Craft, Amphibious Transport Dock, Tank Landing Ship, etc.)

- M Minesweeper
- N Minelayer
- P Fast Motor Craft (Submarine Chaser, Patrol Escort, Motor Gunboat, Motor Torpedo Boat, etc.)
- Q Boat (See paragraph 220)
- R Aircraft Carrier
- S Submarine
- W Coast Guard Ship
- X Submersible Craft
- Y Yard Service Craft

SECTION V - SHORE SIGNAL STATIONS

217. GOVERNMENT SIGNAL STATIONS

Government signal stations on shore or on lightships use "G" as the visual call sign to call any or all of the senior man of war.

218. SHORE SIGNAL STATIONS (COMMERCIAL)

In compliance with International procedure, the letter "K" (with compliment if desired) is used to call or address, shore stations.

219. SIGNAL STATIONS (MILITARY)

In order to standardize the visual call signs for military signal stations, the following assignments are reserved for the signal stations indicated.

CALL SIGN	MEANING	CALL SIGN	MEANING
HpØ	Commander in Chief	Hp1p5	Commander Submarine Base
Hp1	HECP/PWSS (Main Signal Station)	Hp1p6	Degaussing Station No. 1

CALL SIGN	MEANING	CALL SIGN	MEANING
Hp2	HECP/PWSS (Secondary/Auxiliary Signal Station)	Hp1p7	Degaussing Station No. 2
Hp3	Port Director	Hp1p8	Degaussing Station No. 3
Hp4	Senior Officer Present Afloat (SOPA) (when ashore)	Hp1p9	Degaussing Station No. 4
Hp5	SOPA Administrative (when ashore)	Hp2pØ	Deperming Station No. 1
Hp6	Flag officer, Second in Command	Hp2p1	Deperming Station No. 2
Hp7	Commander Naval District	Hp2p2	
Hp8	Commander Naval Base	Hp2p3	
Hp9	Commander Naval Operating Base	Hp2p4	
Hp1pØ	Commander Naval Shipyard	Hp2p5	
Hp1p1	Commander Sea Frontier	Hp2p6	
Hp1p2	Commander Air Station	Hp2p7	
Hp1p3	Commander Amphibious Base	Hp2p8	
Hp1p4	Commander Section Base	Hp2p9	
		Hp3pØ - Hp9p9	Reserved for Local Assignment by competent authority to shore signal stations not covered herein

SECTION VI - SHIPS' BOATS

220. BOAT CALL ASSIGNMENTS

The below listed visual call signs are assigned for ships' boats. Numeral flag(s) following the call sign indicates the individual number of the boat. To call another ship's boat, the call of the parent ship is to be hoisted below the boat call.

CALL SIGN

QpØ	All Boats
Qp1	Admiral's Barge
Qp2	Chief of Staff Barge of Gig
Qp3	Staff Gigs or Motorboats
Qp4	Captain's Gig
Qp5	Boats under power
Qp6	Boats under sail
Qp7	Boats under oars

UNCLASSIFIED

ACP130(A)

Qp8 }
to }
Qp5pØ } Reserved for local assignment by Commanding
Officers. Calls are generated according to
Boat numbers.

EXAMPLES:

1. Qp4Rlp4 Carrier 14 Captain's Gig
2. Qp5p2 Power Boat No. 2 (own Ship)

CHAPTER 3

OPERATING SIGNALS AND PROSIGNS

SECTION I - GENERAL

301. OPERATING SIGNALS

Operating signals consist of the Z and Q codes and will be used in accordance with instructions contained in ACP 131.

302. **PROCEDURE SIGN (PROSIGN)**

One or more letters or characters or combinations thereof, used to facilitate communication by conveying, in a condensed standard form, certain frequently used orders, instructions, requests and information relating to communications.

303. **LIST OF PROSIGNS**

Below is a complete list of prosigns, which are authorized for use in visual signalling. No others may be used. An overscore (a line over two or more letters) indicates that the letters overscored are to be transmitted as a single character, that is, without pause between letters. Description and use of the following prosigns are set forth in subsequent paragraphs.

Prosign	meaning
<u>AA</u>	Unknown station (flashing light only)
<u>AA</u>	All after
<u>AB</u>	All before
<u>AR</u>	End of transmission
AS	Wait
<u>B</u>	More to follow
BT	Long break
C	Correct/Correction
C	Answer sign (semaphore only)(See paragraph 710)
<u>D</u>	Reduce brilliancy or use smaller light
<u>DE</u>	From
EEEEEEEE	Error
F	Do not answer
FM	Originator's sign
G	Repeat back
GR (numeral)	Group count

<u>GRNC</u>	Groups not counted
<u>HM</u> (3 times)	Emergency silence sign
<u>II</u>	Separative sign
<u>IMI</u>	Repeat
<u>INFO</u>	Information addressee sign
<u>INT</u>	Interrogatory
<u>IX</u>	Execute to follow
<u>IX</u> (5 second flash)	Executive signal
<u>J</u>	Verify with originator and repeat
<u>K</u>	Invitation to transmit
<u>L</u>	Relay or relayed (flashing and semaphore only)
<u>NEGAT</u>	Exempted addressee sign (flaghoist only)(See paragraph 807)
<u>NR</u>	Number
<u>O</u>	Immediate
<u>OL</u>	Show steady dim light (flashing light only)(See paragraph 607.f)
<u>P</u>	Priority
<u>PT</u>	Call sign follows (flashing light and semaphore only) (See paragraphs 609 and 707)
<u>R</u>	Received
<u>R</u>	Routine
<u>T</u>	Transmit to
<u>TO</u>	Action addressee sign
<u>W</u>	Information addressee sign (flaghoist only)(See paragraph 807)
<u>W</u>	Your light is unreadable (flashing light only)
<u>WA</u>	Word after
<u>WB</u>	Word before
<u>XMT</u>	Exempted addressee sign
<u>Z</u>	Flash

SECTION II - DESCRIPTION AND USE OF PROSIGNS

304. AA "UNKNOWN STATION (FLASHING LIGHT ONLY)"

AA is used in lieu of a call sign in establishing communication with a station whose call sign is not known or is not recognized. Instructions for use of AA given in paragraph 607.a.

305. AA "ALL AFTER"

AA is used after IMT INT, C, J, and certain operating signals to identify a certain portion of a message. (See paragraph 419.a.)

306. **AB "ALL BEFORE"**

AB is used in the same manner as AA.

307. **AR "END OF TRANSMISSION"**

This prosign means, "This is the end of my transmission to you and no response is required or expected." (in directional flashing procedure, however, a flash for this prosign must be given.) (See paragraph 602.)

308. **AS "WAIT"**

- a. AA made during a transmission and without an ending sign indicates a short pause.

EXAMPLE: R34 DE C69
R - 1Ø2Ø3ØZ NOV
GR5 BT
JOIN CONVOY AT POINT AS

- b. When ready to continue the message, the transmitting ship repeats the last word, group or prosign already transmitted and then proceeds with the remainder of the transmission.
- c. AS followed by AR means, "You are to wait," or "I am obliged to wait," as applicable.
- d. A station having received AS shall wait for K, preceded if required by a call, before transmitting, unless in the meantime he has been given a message of higher precedence to transmit, or it appears he has been overlooked.

309. **B "MORE TO FOLLOW"**

- a. B, used alone in the final- instructions means "More to follow to all stations called."

EXAMPLE: R22 Indicating that she has more to send to ail ships of the screen, transmits:

5 DE R22
- R - 1ØØ93ØZ NOV

GR37 BT
TEXT BT K

- b. In the final instructions, B followed by call signs means "More to follow to stations indicated."

EXAMPLE: 5 DE R22
- R - 100930Z NOV
GR37 BT
TEXT BT- B D32 D46 K

- c. B can be used by a receiving station to indicate that she has traffic for the transmitting station.

EXAMPLE: R B K

- d. B can be used in exceptionally long messages, which may be broken down in groups of 50 to allow the recipient to obtain repetitions and corrections prior to proceeding with the next portion of text.

EXAMPLE: F5 DE R22
- R - 100930Z NOV
GR109
BT
TEXT (50 groups sent)
BT
B 50 K

F5 checks message. If satisfied, he acknowledges receipt of first 50 groups. R22 then sends "-51-" and continues with the message

- e. The receiving station, on receipt of prosign B, is to send the invitation to transmit (prosign K) when ready to receive the next message.

EXAMPLE: <u>R22 makes</u>	<u>C36 makes</u>
<u>C36</u> until answered	K
<u>DE</u>	
Flash	
R22	Flash
R 100930Z DEC 96	Flash
<u>GR37</u>	Flash
<u>BT</u>	Flash

TEXT	Flash
<u>BT</u>	Flash
B	Flash
K	R (C36 receipts for current message)
K	Flash
	Continue with next message

310. BT "LONG BREAK"

BT is used to indicate the separation between the text and other parts of a message. It immediately precedes and follows the text. In abbreviated service messages the BT is not used except when a date-time/time group is employed.

311. C "CORRECT"

C used alone means, "You are correct." C followed by identification data means, "This is a correct version of the message or portion indicated." Instructions for use of C are given in Chapter 4, Section V.

312. D "REDUCE BRILLIANCY OR USE SMALLER LIGHT" (FLASHING LIGHT ONLY)

D is used between operators when it is required to inform a transmitting operator that his light is too large or too bright.

EXAMPLE: As dusk falls D87 is transmitting to R34. R34 informs D87 that his light is unnecessarily bright

Ds (as required).

D87 will adjust his light until R34 sends K.

313. DE "FROM"

- a. DE is used only in the call and means, "This transmission is from the station whose designation follows."
- b. Instructions on calling and answering for the different methods of visual signalling are given in Chapters 6 through 9.

314. EEEEEEEE "ERROR"

- a. To correct errors, a succession of eight or more Es is transmitted and means, "An error in transmission has just been made." (The phrase "eight or more Es" is intended to facilitate operation and shall not be construed as permitting transmission of an excessive number of Es.) In correcting errors in the heading,

the error sign will be followed by the last prosign or operating signal correctly sent. Within the text the error sign will be followed by the last word or group correctly sent. Within the text of signals taken from a naval signal book, the error sign will be followed by BT or the last TACK correctly sent. The operator then continues with the correct version.

- b. To cancel a transmission during transmission, a succession of eight or more Es followed by the prosign AR means, "This transmission is in error, disregard it." This method of canceling a transmission cannot be used after the transmission has been completed.

315. **F "DO NOT ANSWER"**

F transmitted four times preceding a call and once in the transmission instructions means, "Stations called are not to answer this call or to receipt for this message." This is known as "no response" procedure. Messages containing the prosign F are to be transmitted twice. Each transmission of the message will be separated by the prosign IMI (See paragraphs 607.d and 603.a.(6).)

316. **FM "ORIGINATOR'S SIGN"**

FM means, "The originator of this message is indicated by the designation immediately following." (See paragraph 414.)

317. **G "REPEAT BACK"**

- a. G is normally placed in the transmission instructions. It is used by the transmitting station to ensure that the receiving station has received the message as transmitted particularly if the message is of great importance or of a type, which is difficult to transmit or receive. If, during the transmission of a message, it is decided that the use of G is necessary, it may be placed in the final instructions.
- b. G alone means, "All stations called repeat back the message." G preceded by call sign means, "Stations indicated repeat back the message."
- c. The station repeating a message shall repeat the whole message, including the original call, except when only one station was originally called.

EXAMPLE A: (Prosign G in heading)

C42 desires D56 to repeat back a message, transmits:

D56 DE C42
- G -
O 221812Z NOV

GR1Ø BT-
TEXT BT- K

D56 complies as follows:

- G -
O 221812Z NOV
GR1Ø BT
TEXT BT K

C42 transmits:

C AR

If D56 has repeated the date-time group incorrectly, C42 would transmit:

C O TO GR1Ø -
O - 221812Z NOV
GR1Ø K

D56 need only receipt for the corrected portion unless otherwise directed.

EXAMPLE B: (Prosign G in heading, directed ships only repeating)

Commander Task Unit transmits a message to the Task Unit and directs D32 and D34 to repeat back:

8 DE Ø8
- D32 D34 - G -
P - 232125Z NOV
GR1Ø BT
TEXT BT K

D32 and D34 repeat the message as in Example A above except that the original call must be included. When non-directional procedure is used other stations receipt for the message or request repetitions after the repeat back has been completed, otherwise the message is received for in the normal manner.

EXAMPLE C: (Prosign G in ending)

Having completed transmission of the heading D32 desires D34 to repeat back the message:

D34 DE D32

- O - 222324Z NOV
 GR1Ø BT
 TEXT BT
 G K

D34 repeats the message as in Example A above.

- d. A further application of G to instruct a receiving station to repeat a word, limited to flashing light signalling, is explained in paragraph 610.

318. **GR (NUMERALS) 'GROUP COUNT'**

- a. GR followed by numerals is the group count and means, "This message contains the number of groups indicated."
- b. The group count normally appears in the message prefix, but in certain cases may appear in the final instructions. When a message is transmitted before the group count is determined, the prosign GRNC may be used in lieu of the group count. The actual group count will then be transmitted in the final instructions and inserted in the message prefix by the receiving operator.
- c. Further instructions on the use of GR are given in Chapter 4, Section III.

319. **GRNC "GROUPS NOT COUNTED"**

GRNC means, "The groups in this message have not been counted." This prosign is included in the prefix if it is necessary to indicate that the groups have not been counted. It will be included in messages bearing an accounting symbol when the groups are not counted.

320. **HM (TRANSMITTED THREE TIMES) "EMERGENCY SILENCE SIGN"**

- a. Emergency silence may be imposed or lifted by a station only when authorized by competent authority. Emergency silence is not normally used in visual signalling.
- b. When an authentication system is in force a station must always authenticate a transmission which:
- (1) Imposes emergency silence.
 - (2) Lifts emergency silence.
 - (3) Calls stations during a period of emergency silence.

NOTE: When transmission is by visual means and there is no doubt as to identity of stations, authentication is not necessary.

- c. Stations do not answer or receipt for a transmission imposing emergency silence. Thereafter, until directed to resume, stations may transmit only as directed by competent authority or for transmission of an enemy contact report.
- d. $\overline{\text{HM}}$ transmitted three times means: "Cease transmissions immediately. Silence will be maintained until directed to resume." $\overline{\text{HM}}$ $\overline{\text{HM}}$ $\overline{\text{HM}}$ must be followed by amplifying data, e.g., visual means affected, frequency or frequency designator.

- (1) After a call $\overline{\text{HM}}$ $\overline{\text{HM}}$ $\overline{\text{HM}}$ followed by the operating signal ZJM means, "Stations addressed immediately cease all transmissions by visual means indicated."

EXAMPLE: To impose emergency silence on directional flashing light C69 transmits:

R82 DE C69
 $\overline{\text{HM}}$ $\overline{\text{HM}}$ $\overline{\text{HM}}$ ZJM13* $\overline{\text{AR}}$

*ZJM13 means "directional flashing light"

- (2) After a call of $\overline{\text{HM}}$ $\overline{\text{HM}}$ $\overline{\text{HM}}$ followed by a frequency designator means, "Stations addressed immediately cease all transmissions on frequency ... (or that indicated by frequency designator)."

EXAMPLES: To silence R82 on 2700 kHz only C69 transmits:

R82 DE C69
 $\overline{\text{HM}}$ $\overline{\text{HM}}$ $\overline{\text{HM}}$ 2700 $\overline{\text{AR}}$

To silence all on frequency indicated by designator B4, C69 transmits:

2 DE C69
 $\overline{\text{HM}}$ $\overline{\text{HM}}$ $\overline{\text{HM}}$ B4 $\overline{\text{AR}}$

- e. Emergency silence is lifted by addressing the stations concerned and transmitting the operating signal ZUG, meaning "Negative," followed by $\overline{\text{HM}}$ $\overline{\text{HM}}$ $\overline{\text{HM}}$ and amplifying data.

EXAMPLES: To lift emergency silence on directional flashing light C69 transmits:

2 DE C69
 ZUG $\overline{\text{HM}}$ $\overline{\text{HM}}$ $\overline{\text{HM}}$ ZJM13 $\overline{\text{AR}}$

To lift emergency silence for R82 on 2700 kHz only C69 transmits:

R82 DE C69
ZUG HM HM HM 2700 AR

To lift emergency silence for all on frequency indicated by designator B4, C69 transmits:

2 DE C69
ZUG HM HM HM B4 AR

321. **II "SEPARATIVE SIGN"**

- a. II, written as a short dash, is used to prevent mistakes in reception, which might occur if letters or figures of adjacent groups are run together.
- b. In non-directional flashing light and semaphore the separative sign is used as follows:
 - (1) Before and after all prosigns in the procedure and preamble components of the heading except DE AA NR and IX.
 - (2) To separate each element of the address component, i.e., preceding the prosigns FM, TO, INFO and XMT.
 - (3) Between the call and the beginning of the repetition of a message to be repeated back.
 - (4) To separate the address component from the prefix when an accounting symbol is used.
 - (5) To separate call signs belonging to adjacent message elements for adjacent multiple transmission instructions.
 - (6) To separate portions of the text in abbreviated service messages.
 - (7) Between code groups when being sent by flashing light.
- c. In directional flashing light procedure where a flash is given for every word, group or prosign the separative sign need not be used except to avoid ambiguity.
- d. A study of examples throughout this publication will illustrate the use of the separative sign.

322. **IMI "REPEAT"**

- a. IMI means, "Repeat, or I repeat, message or portions of a message as indicated."
- b. IMI without identification data means, "Repeat all of your last transmission."
- c. IMI followed by identification data means, "Repeat the indicated portion of your transmission."
- d. Further instructions on the use of IMI to obtain repetitions are given in paragraphs 418 and to obtain a repetition after a message has been received for.
- e. In the text of a plain language message IMI means I am going to repeat the difficult portion just transmitted." In the text of a message IMI may also
- f. Where messages are made twice through, the two transmissions are separated by

EXAMPLE: R5 DE R6
 - R - 161822Z NOV
GR22 BT
TEXT BT
IMI
 - R - 161822Z NOV
GR22 BT
TEXT BT
 AR

- g. IMI shall not be used to correct an error in transmission.

323. INFO "INFORMATION ADDRESSEE SIGN"

INFO means, "Information addressees are indicated by the designations immediately following." (See paragraph 414.)

324. "INTERROGATORY"

- a. INT operating signals or prosigns indicates that the transmission is in the form of a question.

EXAMPLE: F73 desires to know if the Date Time Group received from D46 is correct, transmits:

D46 DE F73
INT ZII1* 310126Z DEC K

INT ZII1 means, "Is your DTG 310126Z DEC correct?"

- b. INT preceding a portion of a message means, "Is my reception of this correct?"

EXAMPLES: D46 asks F73, "Is the word after 'ships,' "boats?"

F73 DE D46
INT WA SHIPS - BOATS K

D46 asks F73, "Is the date-time group as indicated?"

F73 DE D46
INT 31Ø126Z DEC K

- c. INT may be used in conjunction with the group count prosign as set forth in paragraph 413.
- d. INT cannot be used to question any part of a message for which a receipt has been given. An abbreviated service message in conjunction with the prosign C to question or query a portion or a message, which has been receipted for will be used for this purpose.

EXAMPLE: D46 asks D45 "Is the word after 'ships', "boats?"

D45 DE D46
BT INT C D45 1248Z WA SHIPS BOAT BT 1308 K

325. IX "EXECUTE TO FOLLOW"

The uses of the execute to follow prosign are set forth under "The Executive Method" in Chapter 6.

326. IX (5 second flash) "EXECUTIVE SIGNAL"

The uses of the executive signal, a 5 second flash preceded by IX are set forth under "The Executive Method" in Chapter 6.

327. J "VERIFY WITH ORIGINATOR AND REPEAT"

Used only as prescribed in Chapter 4, Section V.

328. K "INVITATION TO TRANSMIT"

K means, "Invitation to transmit" or "This is the end of my transmission to you and a response is necessary."

329. **L "RELAY" OR "RELAYED" (FLASHING LIGHT AND SEMAPHORE ONLY)**
- a. The letter L in the transmission instructions means "Relay to those addressees for whom you are responsible." When final relay ships have obtained a receipt from ships for whom they are responsible, they report up the chain of visual responsibility by making L. First relaying ships only are to report to the originator. If relaying responsibility is automatic L may be omitted. This prosign will not be used when the original transmission is by "no response" procedure.
 - b. L alone or with identification data means, "Message or message indicated has been delivered to all addressees for whom this station is responsible and intervening relay ships have reported delivery to ships for whom they are responsible."
 - c. L preceded by $\overline{\text{INT}}$ and followed, if necessary, with identification data means, "Have you relayed my last message or message indicated?"

EXAMPLE: $\overline{\text{INT}}$ L 627Z means, "Have you relayed my 1627Z?"
 - d. Full use of prosign L is given in paragraph 606.
330. **NEGAT "EXEMPTED ADDRESSEE SIGN" (FLAGHOIST ONLY)**
- Flaghoist equivalent of XMT. (See paragraph 807.)
331. **O "IMMEDIATE"**
- O means "Immediate message." (See Chapter 4, Section II.)
332. **P "PRIORITY"**
- P means "Priority message." (See Chapter 4, Section II.)
333. **R "ROUTINE"**
- R means "Routine message." (See Chapter 4, Section II.)
334. **R "RECEIVED"**
- a. After a transmission, which has ended with a K, R given in response means, "I have received your last transmission."
 - b. After a transmission, R preceded by $\overline{\text{INT}}$ means, "Have you received my last transmission?"

EXAMPLE: INT R

- c. After a transmission, R preceded by INT and followed by identification data means, "Have you received the message indicated?"

EXAMPLE: C95 asks N12, "Have you received R33's 121416Z?"

N12 DE C95
INT R R33 121416Z DEC K

- d. After receipt of a message, R followed by identification data means, have received the message indicated."

EXAMPLE: N12 indicated to C95 that he has received R33's 121416Z:

C95 DE N12
R R33 121416Z DEC K

335. T "TRANSMIT TO"

- a. T, when used, shall appear in the transmission instructions.
- b. T alone means, "Station called transmit this message to all addressees in the address component."

EXAMPLE: D48 directs F73 to transmit to all addressees:

F73 DE D48
- T
- R 311615Z DEC
- FM D48
- TO F73 F78
- BT etc.

- c. T followed by address designations means, Station called transmit this message to the addressees whose address designations follow."

EXAMPLE: D48 directs F73 to transmit a message to A32:

F73 DE D48
T A32
- R 171831Z NOV
- FM D48
- TO A32

- INFO C75
GR18
 BT etc.

- d. T preceded by a call sign and followed by address designations means, "Station whose call sign precedes T, transmit this message to the addressees whose address designations follow T."

EXAMPLE: C75 calls both F73 and R33 and directs R33 to transmit message to D48:

- F73 R33 DE C75
 - R33 -T- D48
 -R- 181927Z NOV
 -FM C75
 -TO D48
 - GR29
 - BT etc.

- e. T may be modified by use of the operating signal ZWL* to denote that no forwarding action is required to the address designations which immediately follow ZWL.

EXAMPLE: 08 has transmitted a message to D32, a ship in his unit by other means. He calls D21 and directs him to relay the message but that no forwarding action is required to D32:

D21 DE 08
 T ZWL D32
 R 030201Z NOV
 FM 08
 TO 83
GR15
 BT etc.

*ZWL means, "No forwarding action to the designations immediately following is required."

336. T "IN CODRESS MESSAGES"

- a. In codress messages the stations for whom the message is intended, as a result of a particular transmission, are indicated in the transmission instructions, except that when a codress message is being passed direct to one or more stations, all of which are required to decrypt, no passing instructions are necessary.

- b. Where retransmission is involved, it is ESSENTIAL that the prosign T be followed by the designations of all stations or addressees which are required to decrypt the message as a result of that particular transmission. Thus when a station has to retransmit AND decrypt a message his designation, as well as that of the station to whom he is to retransmit the message, must follow T.

EXAMPLES: All stations called are required to decrypt and none is required to retransmit the message:

M31 M86 N57 DE C46 -
 - P - 26173ØZ NOV
 GR56 BT -
 TEXT BT - K

M86 is NOT REQUIRED to decrypt but IS required to retransmit the message to F73:

M31 M86 N57 DE C46 -
 M86 - T - F73
 - P - 26174ØZ NOV
 GR64 BT -
 TEXT BT K

M86 is required to decrypt and ALSO to retransmit the message to F73:

M31 M86 N57 DE C46 -
 M86 - T - M86 F73
 - P - 26175ØZ NOV
 GR6Ø BT -
 TEXT BT K

337. **TO "ACTION ADDRESSEE SIGN"**

TO means, "Addressees indicated by the designations immediately following are addressed for action." (See paragraph 414.)

338. **W "INFORMATION ADDRESSEE SIGN" (FLAGHOIST ONLY)**

W, used in flaghoisting procedure is the equivalent of INFO. (See paragraph 323 and 807)

339. **W "LIGHT UNREADABLE" (FLASHING LIGHT ONLY)**

W, used in flashing light procedure, means, "Your light is unreadable." If a receiving operator is unable to read a transmitting station due to improper training of the light, or the light is of insufficient brilliance, he may indicate this by sending Ws as required. The transmitting operator will then train a steady light, increasing brilliancy if appropriate, until the receiving operator sends K.

340. **WA "WORD AFTER"**

WA is used after $\overline{\text{IMI}}$, INT, C, J and certain operating signals to identify a certain portion of the text of a plain language message. (See paragraph 419.b.)

341. **WB "WORD BEFORE"**

WB is used in the same manner as WA. (See paragraph 419.b.)

342. **XMT "EXEMPTED ADDRESSEE SIGN"**

XMT means, "The stations or addressees immediately following are exempted from the collective call or address."

EXAMPLES: In the call:

2 - XMT - A35 DE 48

In the address:

- R - 121617Z NOV

FM 48

TO 2

XMT A35

GR2Ø BT- etc.

343. **X "BREAK IN"**

Prosign X is to be used only with directional procedure to break in on a transmission in order to pass a message of higher precedence. It must be authorised by competent authority. 'X' as a single transmission means 'I have a message of higher precedence and will await your invitation to transmit'. On receipt of 'X' the receiving station is to send 'K' when ready to receive the higher precedence message.

344. **Z "FLASH"**

Z means, "Flash message." (See Chapter 4 Section II.)

CHAPTER 4

VISUAL PROCEDURE

SECTION I - GENERAL

401. **TRANSMITTING TECHNIQUES AND TRANSMITTING SPEEDS**

- a. Each character shall be transmitted clearly and distinctly. The speed of transmission shall be governed by the prevailing conditions and the capability of the receiving operators.
- b. Accuracy in transmission is far more important than speed. The difference in time required to send a message at 10 words per minute and that required to transmit at 15 words per minute is slight. Even this slight gain in time may be nullified by any added time required for repetitions.
 - (1) The speed at which the receiving operator can copy without having to obtain repetitions is the speed at which the transmitting operator should transmit. When transmitting to more than one station the governing speed of the transmitting operator is to be that of the slowest receiving operator.
 - (2) The speed of transmitting headings should be slower than the speed of transmitting of texts.

402. **LOGS AND FILES**

- a. Every signal transmitted or received by visual means shall be logged, together with the time of execution, in a suitable record book.
- b. A file of all messages transmitted or received by visual means shall be kept to facilitate future reference.

403. **CALL SIGNS**

- a. The following call signs are authorized for use in calling and answering: visual call signs, international call signs, tactical call signs, task organization call signs, collective call signs and indefinite call signs. Address groups may be used as call signs by Coast Guard and Navy commands (except in non-military communications).
- b. Call signs and address groups in message headings will ordinarily be arranged in alphabetical order in the form in which they are to be transmitted, whether plain,

encrypted, or mixed. For this purpose, / (slant sign) and figures 1 through 0 will be considered the twenty-seventh through thirty-seventh letters of the alphabet. Care must be taken to avoid separating groups of related call signs or conjunctive address groups, which are interdependent.

- c. The different methods of visual signalling require variations in procedure for calling and answering. The necessary instructions for each method are prescribed in Chapters 6 to 9 inclusive.

404. **MESSAGE TRANSMISSION**

Messages shall be transmitted exactly as written. Abbreviations shall not be substituted for plain language or plain language substituted for abbreviations.

SECTION II - USE OF PRECEDENCE PROSIGNS

405. **RESPONSIBILITY**

The assignment of precedence to a message is the responsibility of the originator and is determined by the subject matter of the text and the time factor involved.

406. **SIGNIFICANCE**

Precedence designations are employed to indicate the relative order in which a message of one precedence designation is handled with respect to messages of other precedence designations. Precedence designations indicate:

- a. To the Originator - The required speed of delivery to the addressee.
- b. To Communication Personnel - The relative order of handling and delivery.
- c. To the Addressee - The relative order in which he should note the message.

407. **PRECEDENCE DESIGNATIONS AND COMMUNICATION HANDLING**

Messages will be handled in accordance with the precedence explained below.

- a. FLASH precedence will be indicated by the prosign Z. FLASH messages will be processed, transmitted and delivered in the order received and ahead of all other messages. Messages of lower precedence will be interrupted on all circuits involved until handling of the FLASH message is completed.
- b. IMMEDIATE precedence will be indicated by the prosign O. IMMEDIATE messages are processed, transmitted and delivered in the order received and

ahead of all messages of lower precedence. Processing and transmission of lower precedence message already in progress will be interrupted unless interrupting and canceling the lower precedence transmission will take longer than completing it.

- c. PRIORITY precedence will be indicated by the prosign P. PRIORITY messages are processed, transmitted and delivered in the order received and ahead of all messages of lower precedence. ROUTINE messages being transmitted should not be interrupted unless they are extra long.
- d. ROUTINE precedence will be indicated by the prosign R. ROUTINE messages are processed, transmitted and delivered in the order received and after all messages of higher precedence.

408. INDICATING PRECEDENCE IN PRELIMINARY CALL

Precedence may be indicated in a preliminary call as follows:

Z indicates "I have Flash precedence traffic to transmit." O indicates "I have Immediate precedence traffic to transmit." P indicates "I have Priority precedence traffic to transmit." R indicates "I have Routine precedence traffic to transmit." For an example of an emergency alarm report utilising precedence 'Z' (Flash) see para 607e.

EXAMPLE: A68 tells D45, "I have Priority precedence traffic to transmit."

D45-P (repeated until answered by D45)

409. SINGLE PRECEDENCE

The precedence shall be indicated by the appropriate precedence prosign and will appear as the first element of the preamble.

410. DUAL PRECEDENCE

- a. Multiple address messages having both action and information addressees may either be assigned a single precedence, in which case it indicates the precedence for all addressees, or they may be assigned two precedences, one for all action addressees and a lower one for all information addressees.
- b. Where dual precedence is indicated, the higher precedence will appear first.

EXAMPLE: Priority precedence to M72, Routine to D19:

M72 D19 DE Ø1 -
P - R - 16153ØZ NOV -

FM Ø1 -
 TO M72 -
 INFO D19 -
 GR14 BT etc.

SECTION III - GROUP COUNT

411. RULES FOR COUNTING GROUPS

- a. Count groups in text only.
- b. Punctuation and symbols are not counted unless spelled out or abbreviated.
- c. A sequence of characters not interrupted by a space is counted as one group.
- d. The proper names of countries, cities or streets consisting of two or more separate words should normally be written and counted as one group, i.e., San Salvador, San Diego, Salt Lake City, but when written separately they will be transmitted and counted as separate groups, i.e., Fifth Avenue.
- e. The following text is counted as 19 groups:

SHIPMENT BRAY HYPHEN CORBIE SHOULD HAVE BEEN MARKED
 BRAY-CORBIE. FUTURE SHIPMENTS FOR PAREN FRANCE UNPAREN
 SHOULD BE MARKED (FRANCE).

f. EXAMPLES:	<u>Group Count</u>
BRAY HYPHEN CORBIE	3
BRAY-CORBIE	1
NEWYORK	1
XFUY	1
CNYR NKLY JVRN	3
(FRANCE)	1
PAREN FRANCE UNPAREN	3
125/3	1
CG	1
125-3/3-55-X56	1
35 DASH 567P	3
MR C D ADAMS	4
BF6 311845Z	2
/124.Ø-13Ø.6	1
AND/OR	1
(288 72 53)	3

412. **PLAIN LANGUAGE TEXTS**

The group count element may be omitted in messages where the text consists of plain language.

413. **CHECKING GROUP COUNT**

- a. GR preceded by $\overline{\text{INT}}$ and followed by numeral(s) means, "Is the number of groups as indicated?" When the number of groups received does not correspond with the group count transmitted, the receiving station will immediately question the transmitting station by using INT GR followed by numeral(s).

EXAMPLE: $\overline{\text{INT}}$ GR8 K

If after rechecking the message the transmitting station finds that the receiving station is correct, the transmitting station sends: C K

- b. For all plain language messages, and for encrypted messages where the group count does not exceed 5Ø groups, if the receiving station is considered to be incorrect, the transmitting station repeats the original group count and transmits the first character of each word or group in the text in succession.
- c. EXAMPLE: Ø5 transmits a message to D83:

D83 DE Ø5
 - R - 272123Z NOV
 GR1Ø $\overline{\text{BT}}$
 RECEIVED SHIPMENT TWO TRUCKS FROM PARIS
 PAREN FRANCE PAREN TODAY
 $\overline{\text{BT}}$ K

D83 questions the group count:

$\overline{\text{Ø5}}$ DE D83
 $\overline{\text{INT}}$ GR11 K

Ø5 checks and finds the group count correct as transmitted, then transmits:

D83 DE $\overline{\text{Ø5}}$
 GR1Ø $\overline{\text{BT}}$ R S T T F P P F U T $\overline{\text{BT}}$ K

- d. For encrypted messages with a group count exceeding 5Ø groups, if the receiving station is considered to be incorrect, the transmitting station repeats the original group count and transmits the identity of the first, eleventh and every subsequent tenth group, followed by the initial letter of that group. The identity of the group will be-separated from the initial letter of the group by a separative sign.

EXAMPLE: Ø5 transmits a message to D83 containing 76 groups. D83 questions the group count: INT GR75 K Ø5 checks and finds the group count correct as transmitted, then transmits:

GR76 BT 1 - D 11 - L 21 - H 31 - P 41 - Q 51 - M 61 - W 71
- F- BT
K

D83 then requests a repetition of the ten groups in which he has a miscount:

IMI 31 TO 4Ø K

- e. Subject to the above checking of the group count the group count as decided by the transmitting station is final.

SECTION IV - MESSAGE ADDRESS

414. USE OF PROSIGNS FM, TO AND INFO

- a. The prosigns FM, TO, and INFO are used to indicate the beginning of the originator format line, the action addressee format line and information addressee format line respectively. In plaindress messages these prosigns shall be followed by call signs, address groups or plain language.
- b. When there are only action addressees, INFO is omitted; when there are only information addressees, TO is omitted. (XMT may be used to exempt stations from a collective action or information address.) (See paragraph 342.)

EXAMPLE A: All addressees (C42 and R33) are action addressees in a message originated by C32.

- R - 161215Z NOV
FM C32 -
TO C42 R33
GR18 BT etc.

EXAMPLE B: All addressees (D26 and F79) are information addressees in a message originated by C32.

- R - 310745Z NOV
FM C32 -
INFO D26 F79
GR19 BT - etc.

EXAMPLE C D26 is an action addressee and F79 is an information addressee in a message originated by C32.

- R - 172215Z NOV
FM C32 -
TO D26 -
INFO F79
GR12 BT - etc.

415. CALL SERVING AS ADDRESS

In plaindress or abbreviated plaindress messages when the originator is in direct communication with the addressees the call will serve as the address. This is possible only when the call designations of the stations used in calling and answering are the same as those assigned the originator and addressees.

EXAMPLE A: When all addressees are action:

D26 F79 DE C32
- R - 161512Z NOV
GR18 BT - etc.

EXAMPLE B: When there are both action and information addressees: In addition to being in the call line, the information addressee must be indicated by the operating signal ZFH2 followed by the designation of the information addressee.

D26 F79 DE C32
*ZFH2 F79
- R - 161512Z NOV
GR18 BT - etc.

EXAMPLE C: When all addressees are information: This is indicated by the inclusion of the operating signal ZFH2 with no address designations following.

D26 F79 DE C32

*ZFH2 -
 - R - 161512Z NOV
 GR18 BT etc.

*ZFH2 means: This message is being passed to you for information.

416. READDRESSING MESSAGES

- a. When an addressee desires to readdress a message to ships or stations not included in the original address, he may do so by employing the operating signal ZFH followed by 1 or 2 (indicating for action or information) in the transmission instructions, the call serving as the address.

EXAMPLE: D5Ø6 F64 DE D83
 ZFH1 D5Ø6 ZFH2 F64
 - P - 21Ø917Z DEC -
 FM C46
 TO D83
BT - etc.

- b. When the authority desiring to readdress the message is not in visual communication with the desired addressees, the procedure outlined in ACP 124 will be employed in the heading.

SECTION V - IDENTIFICATIONS, CORRECTIONS, REPETITIONS, VERIFICATIONS, CANCELLATIONS, ACKNOWLEDGEMENTS

417. IDENTIFICATION OF MESSAGES

- a. Messages should normally be identified by the use of the date-time group/time group, the designation of the originating station and/or the group count. When identifying messages, the data used shall be as brief as possible, consistent with positive identification. Care should be exercised when identifying encrypted messages that no plain language reference is made to address or text portions, which were encrypted.
- b. Parts of messages are identified as shown in the examples below. If a word or group occurring more than once in a message is used to identify part of that message, it is to be assumed that the first occurrence of that word or group is implied. If otherwise intended, amplifying data such as adjacent words or groups must be included.

EXAMPLES: AB BT denotes all before the text.

AA LUXO BT - denotes the message ending, where LUXO is the last group in the text.

AA BT - denotes the complete text and message ending.

- c. In requesting repetitions of the heading of a message, a repetition may be requested of all that portion preceding a prosign, or that portion between any two prosigns. Thus requests for repetitions and replies thereto must include the nearest prosigns following, or preceding and following, the portion requested.

418. CORRECTIONS AND REPETITIONS

- a. Errors or omissions noted by the transmitting operator shall be corrected as follows:
- (1) During transmission - the operator shall transmit the error prosign, repeat the last word, group, prosign or operating signal correctly transmitted before the error, followed by the corrected word, group or prosign, and continue with the transmission.
 - (2) When transmission is completed but before a receipt is obtained - the operator shall use the as follows:
 - (3) Before a receipt has been given by appropriate prosigns.

EXAMPLE: BT
C D45 1248 WA REPORT COMMANDERS
BT 1306Z K

- (4) After a receipt has been given by a service or abbreviated service message.

NOTE: The prosign IMI cannot be used to request repetitions after a receipt has been given.

Opsigs. INT ZDK and ZDK preceding message identification and requested portion must be used.

EXAMPLE D46 requests a repetition of word after soonest

Request: D45 DE D46
BT
INT ZDK D45 1248 WA SOONEST
BT 1324Z K

Reply: D46 DE D45
 BT
 ZDK D45 1248Z WA SOONEST REPLIES
 BT 1330Z K

Note: INT ZDK means "Will you repeat message (or
 portion)"

ZDK means "following repetition (of.....) is made in accordance
 with your request.

- b. A service or abbreviated service message employed to obtain repetitions or send corrections is normally assigned a precedence equal to that of the message to which it refers.
- c. Corrections sent without request are preceded by the prosign C with appropriate identifying data where necessary, and transmitted in the same manner as those sent in answer to a request for repetition, correction or verification.
- d. When repetitions of portions of a message containing the call are made, the original call must be repeated in such repetitions except when only one station was called originally.

419. **EXAMPLES OF REPETITIONS**

- a. Original message (transmitted by non-directional means):

2 DE D3
 - R - 271545Z OCT -
 FM D3 -
 TO R8 -
 INFO D SQUAD 3
 GRU BT -
 BAXTE - RSTAN - LEYHA - RRYFI - RSTGR - ANDSO
 NOFFR - ANKAN - DLAUR - IEXDW - GTAET BT - K

EXAMPLE A: Repetition of the last transmission:

Request: D3 DE R8
 IMI K

Reply: R8 DE D3
 2 DE D3
 R - 271545Z OCT -

UNCLASSIFIED

ACP130(A)

FM D3
TO R8
INFO D SQUAD 3
GRll BT
BAXTE - RSTAN - LEYHA - RRYFI- RSTGR - ANDSO -
NOFFR - ANKAN - DLAUR - IEXDW - GTAET BT - K

EXAMPLE B: Repetition of all. before the text:

Request: D3 DE R8
IMl AB BT - K

Reply: R8 DE D3
AB BT -
2 DE D3 -
R - 271545Z OCT
FM D3 -
TO R8 -
INFO D SQUAD 3
GRll BT- K

EXAMPLE C: Repetition of all before INFO:

Request: D3 DE R8
IMl AB INFO K

Reply: R8 DE D3
AB INFO
2 DE D3
R - 271545Z OCT
FM D3 -
TO R8 -
INFO K

EXAMPLE D: Repetition of all between FM and INFO:

Request: D3 DE R8
IMl FM TO INFO K

Reply: R8 DE D3
FM TO INFO
FM D3 -
TO R8 -

UNCLASSIFIED

ACP130(A)

INFO K

EXAMPLE E: Repetition of all before the fourth group:

Request: D3 DE R8
IMI AB 4 K

Reply: R8 DE D3
AB 4 -
2 DE D3 -
R - 271545Z OCT -
FM D3 -
TO R8 -
INFO D SQUAD 3
GR11 BT- BAXTE - RSTAN - LEYHA BT K

EXAMPLE F: Repetition of the third and sixth to eighth groups:

Request: D3 DE R8
IMI 3 - 6 TO 8 K

Reply: R8 DE D3
3 - LEYHA - 6 TO 8 - ANDSO - NOFFR - ANKAN K

EXAMPLE G: Repetition of all after the eighth group:

Request: D3 DE R8
IMI AA 8 K

Reply: R8 DE D3
IMI AA 8 ANKAN -DLAUR - IEXDW - GTAET BT K

EXAMPLE H: Repetition of the ninth group:

Request: D3 DE R8
IMI 9 K

Reply: R8 DE D3
IMI 9 - DLAUR K

EXAMPLE I: Repetition of the third to eighth groups:

Request: D3 DE R8

IMI 3 TO 8 K

Reply: R8 DE D3
3 To 8 -
LEYHA - RRYFI - RSTGR - ANDSO - NOFFR - ANKAN K

EXAMPLE J: Repetition of the date-time group, originator and action addressee

Request: D3 DE R8
IMI R TO INFO K

Reply: R8 DE D3
R TO INFO -
R - 271545Z OCT -
FM D3 -
TO R8 -
INFO K

- b. In plain language messages, portions of the text are identified as words rather than as numbered groups. The prosigns WA and WB are used as appropriate (see paragraphs 340 and 341).

EXAMPLE A:

Request: D3 DE R8
IMI WA CARRY K

Reply: R8 DE D3
WA CARRY - OUT K

EXAMPLE B:

Request: D3 DE R8
IMI CARRY TO SIXTEEN K

Reply: R8 DE D3
CARRY TO SIXTEEN -
CARRY OUT PLAN SIXTEEN K

- c. To obtain a repetition after receipt has been given, an abbreviated service message should be sent containing an appropriate operating signal, identification data of the message in question and the portion or portions required.

Original message (transmitted by directional procedure)

D9 DE F2

BT

REQUEST AVAILABILITY OF ITEM 9166-66-134-2748 AS REQUESTED

BT

1115Z

K

EXAMPLE: After receipting for the message, D9 requires a repetition of the portion between ITEM and AS

F2 DE D9

INT ZDK

PT F2 1115Z

ITEM TO AS

K

F2 will reply

ZDK PT F2 1115Z ITEM TO AS -

ITEM 9166 - 66 - 134 - 2748 AS -

K

420. VERIFICATIONS

- a. Under certain conditions, addressees of a message may wish to verify with the originator either the whole of the message or a portion thereof. This may be done by means of abbreviated service, service or formal message as appropriate. However, it is emphasized that only an addressee may request a verification, and the reply thereto must be authorized by the originator of the message in question. Operators are not permitted to originate a request for a verification or reply thereto.
- b. In most cases, a message will be receipted for before the need for a verification becomes evident. In those cases where it is apparent, prior to receipting for a message, that a verification will be required (e.g., when the text is such that its meaning is readily determined by an addressee who is immediately available to the operator), verification may be requested at once instead of first receipting for the transmission.
- c. The prosign J after a call and followed by identification data, when necessary, means "Verify with the originator and repeat message or portion indicated."

- d. The prosign J may be used to request verification of:
- (1) The entire message.
 - (2) The heading, or any portion of the heading.
 - (3) The entire text of any message.
 - (4) A portion of the text of a plain language message.
 - (5) A portion of the text of a message from a signal book
 - (6) Portions of the text of encrypted messages, when the crypto system employed permits. When the prosign J is used for this purpose, numerals are to be used to indicate the groups requiring verification.
 - (7) For verifications of executive messages see para 616.

421. EXAMPLES OF VERIFICATIONS

Original message:

D DIV 5 DE ØD -
 R - 181545Z DEC -
 FM ØD -
 TO D56 D78 -
 INFO D31
 BT
 PROCEED ON DUTY ASSIGNED. MAKE MOVREPS BT K

EXAMPLE A: D31 desires verification and repetition of the entire message and originates a message accordingly.

ØD DE D31
 J 181545Z DEC K

The operator, having receipted for the abbreviated service message, verifies with the originator and sends the reply:

D31 DE ØD
 C 181545Z OCT -
 D DIV 5 DE ØD
 R - 181545Z OCT -
 FM ØD

UNCLASSIFIED

ACP130(A)

TO D56 D78 -
INFO D31
BT
PROCEED ON DUTY ASSIGNED. MAKE MOVREPS BT
K

EXAMPLE B: D31 desires verification and repetition of the heading and originates a message accordingly.

ØD DE D31
J 181545Z OCT AB BT - K

The operator, having receipted for the abbreviated service message, verifies with the originator and sends the reply.

D31 DE ØD
C 181545Z OCT AB BT -
D DIV 5 DE ØD -
R - 181545Z OCT -
FM ØD -
TO D56 D78 -
INFO D31
BT - K

EXAMPLE C: D31 desires verification and repetition of the address and originates a message accordingly.

ØD DE D31
J 181545Z OCT FM TO BT K

The operator, having receipted for the abbreviated service message, verifies with the originator and sends the reply:

D31 DE ØD
C 181545Z OCT FM TO BT -
FM ØD
TO D56 D78 -
INFO D31
BT K

EXAMPLE D: D31 desires verification and repetition of all after "assigned" and originates a message accordingly.

ØD DE D31

J 181545Z OCT AA ASSIGNED K

The operator, having receipted for the abbreviated service message, verifies with the originator. As a result, the originator discovers that he has made an error in the original message and orders it to be corrected to read "Make own movreps." The operator transmits the correction to all original addressees as follows:

D DIV 5 DE ØD
 C 181545Z OCT
 AA ASSIGNED - MAKE OWN MOVREPS BT K

422. ACKNOWLEDGEMENTS

An acknowledgment is a communication indicating that the message to which it refers has been received and the purport is understood by the addressee. Instructions to acknowledge mean "An acknowledgment of this message (or message indicated), when understood, is required," and may be included in the original transmission or by separate message.

423. EXAMPLES OF ACKNOWLEDGEMENTS

EXAMPLE A: C58 sends R34 a message, Ø51218Z, without requiring an acknowledgment. After receipt has been obtained, C58 desires an acknowledgment and transmits:

R34 DE C58
 INT ZEV* Ø51218Z OCT K

R34 receipts in the normal manner, and when the message is understood by the addressee, transmits the acknowledgment and obtains a receipt:

C58 DE R34
 ZEV** Ø51218Z OCT K

The operating signal INT ZEV* may be placed in the heading as the last element of the preamble:

EXAMPLE B: D51 DE C58

INT ZEV*
 BT GOLF BRAVO BT K

D51 receipts in the normal manner, and when the message is understood by the addressee, transmits the acknowledgment and obtains a receipt:

C58 DE D51 ZEV** K

*INT ZEV means "Request you acknowledge message

**ZEV means "Message (or message....) is acknowledged."

424. **DUPLICATE OR SUSPECTED DUPLICATE MESSAGES**

When it is necessary to send an exact duplicate of a message previously transmitted or believed to have been transmitted, the appropriate operating signal shall be placed in the message instructions if the duplicate message is initiated by the originating station, or in the transmission instructions if the duplicate transmission is initiated by a relaying station.

425. **CANCELLATIONS**

Cancellation of a message, which has been acknowledged or receipted for may be accomplished only by a new message properly authorized.

EXAMPLE:

D46 DE D45
BT
CANCEL D45 1248Z
BT
1405Z K

SECTION VI - RULES FOR REFILING MESSAGES

426. **MESSAGES IN BASIC FORMAT**

- a. Messages, which have been received in the basic message format, employing a procedure other than visual procedure (e.g., tape relay, radiotelegraph, etc.) will require reprocessing before they are forwarded by visual means. Such reprocessing is accomplished as outlined below.
 - (1) Delete the procedure component in the heading and insert any required transmission instructions, using procedure outlined in this publication.
 - (2) Routing indicators and operating signals indicating delivery by other means when appearing in format lines 7 or 8 may be deleted.

- (3) Confirmatory information, when appearing in the ending component of the message, will be compared with the text and then deleted prior to retransmission. When a difference is noted between the confirmation line and the comparable portion in the text, the message will be relayed to the addressee with the appropriate operating signal meaning substantially "Confirmation differs from text." The operating signal thus employed will appear as the first portion of the final instructions and will be followed by the portion of the confirmation line, which is at variance with the text. This operating signal will remain a portion of the final instructions to final destination.
 - (4) Corrections, when appearing, will be made as appropriate within the text and then deleted.
 - (5) Time of filing, when appearing, will be deleted.
 - (6) The appropriate visual procedure lines, as prescribed in paragraph 117 will be inserted in the heading and ending components of the message prior to re-transmission.
 - (7) Radiotelephone call signs should not normally be used in the address portion of messages, which are to be passed by visual means. If a message is received from a radiotelephone circuit employing radiotelephone call signs, these call signs will be converted (if the appropriate call sign books are available) to the appropriate call signs and address groups prior to onward transmission by visual means.
- b. In order to prevent confusion when transmitting refiled messages containing incomplete groups, the slant/oblique stroke will be used to indicate the missing characters. When the location of the missing characters cannot be readily determined, the slant/oblique stroke will be transmitted at the beginning of the questionable group. Particular care must be exercised to ensure that confusion does not result from use of the slant/oblique stroke in plain language messages.

CHAPTER 5

VISUAL RELAY RESPONSIBILITY

501. GENERAL

In visual communication systems relaying is accomplished automatically when the call up is made by using collective call signs. A message should be relayed concurrent with its reception, when possible, in order to minimize the time delay between the end of the originator's transmission and its delivery to the final addressee.

502. CHAIN OF VISUAL RESPONSIBILITY

- a. The general rule for determining the responsibility for any situation is that each addressee is responsible for the delivery of the messages to addressees beyond himself in the general direction away from the originator. No rule set forth herein, or prescribed by responsible commanders, shall be interpreted as restricting the initiative of any ship in relaying a message to an addressee who does not respond when called. It is the duty of any ship to expedite the transmission of a message by relay when it is evident that she is in a better position to effect the necessary relay than the ship specifically responsible.
- b. Alterations - When a maneuver alters the position of units and ships relative to the Officer in Tactical Command (OTC), the responsibility for relaying signals does not alter until the maneuver is completed by all ships.

503. CHAIN OF VISUAL RESPONSIBILITY - DIRECTIONAL METHOD

- a. Single Line Formations - Any given ship is responsible for the ships beyond and in the direction away from the originating ship.
- b. Multiple Line Formations:
 - (1) The originator of a signal in multiple line formation is responsible for:
 - (a) Ships in his own line.
 - (b) Ships occupying the corresponding position in the lines immediately adjacent to his own line.
 - (2) Ships occupying the corresponding position to the originator are responsible for:
 - (a) Ships in his own line.

- (b) Ships occupying the corresponding position in the lines immediately adjacent but in the direction beyond and away from the originating ship.
 - (3) Individual ships are responsible for the ships in their own line in the direction beyond and away from their own relay unit.
- c. Operational Formations and Dispositions - In any operational formation or disposition the chain of visual responsibility is governed by the rules set forth above unless modified by responsible commanders. It may be necessary for commanders to promulgate detailed relaying instructions or diagrams showing sectors of visual responsibility to ensure that visual signals are cleared as quickly as possible. In assigning responsibility consideration should be given to the relative capabilities of the various ships, i.e., type of visual equipment installed, personnel limitations, type formations, etc.

504. **REPEATING SHIPS**

- a. A repeating ship is any ship through which a message is relayed, the term "repeating ship" includes:
 - (1) A ship specifically designated as a repeating ship.
 - (2) A ship, which automatically relays.
 - (3) A ship, which elects to relay to facilitate signalling.
 - (4) A ship through which a message is routed.
- b. The function of a ship specifically designated as a repeating ship is to act as a primary relay station to facilitate communications.

CHAPTER 6

FLASHING LIGHT

601. PROCEDURES

- a. Directional procedure - Always employed when using a directional light. It is also employed when using a non-directional light when the call is that of a single station.
- b. Non-directional procedure - One station may transmit to a number of other stations simultaneously by means of a light showing over a wide area.
- c. Use of Signal Lights
 - (1) General.
 - (a) In wartime the greatest care is to be taken when signalling at night. Flashing light is to be used only when necessary and a minimum of light employed, except when making recognition signals when a light of sufficient brilliancy is to be used to ensure its being immediately seen. It must, however, always be remembered that in heavy weather destroyers and small ships have difficulty in reading dim lights, due to movement and sea.
 - (b) The background must always be considered and care should be taken not to use a signalling light close to or in line with navigation lights.
 - (c) No upper deck lighting should be visible on or in the vicinity of the signal deck.
 - (2) At dusk and dawn.
 - (a) In wartime the use of signal lights at dusk and dawn must be avoided whenever possible. If, however, their use is unavoidable, signalers must pay constant attention to the brilliancy of their lamps.
 - (b) Signal lights are to be carefully tested for leakage of light.
 - (3) At night.
 - (a) A constant watch is to be kept on the ship of the OTC by all other ships.

- (b) It may often be found, after communication has been established, that the brilliancy of the light can be still further reduced.
- (c) It is absolutely essential when using any type of directional light, to keep it trained accurately throughout transmission of the message.
- (4) At all times.
 - (a) Ships are to inform other ships signalling to them when their lights are observed to be brighter than necessary, by the use of the prosign D.
 - (b) Sighting arrangements of lights are to be frequently tested for alignment.
 - (c) To prevent masthead and yardarm signalling lights from being accidentally lighted, the switch in the power supply line should be kept open until use of the light is actually required.

602. **DIRECTIONAL PROCEDURE**

- a. The transmitting station waits for the receiving station to make a flash for each prosign, word, code group or operating signal. Should the receiving station fail to read a prosign, word, code group or operating signal, it will be repeated by the transmitting station.
- b. An exception to this rule is that a flash is not necessary to the prosign K when there is an immediate response to K. A flash should be made to K in the message ending when there will be a delay while checking the message to ensure its completeness.
- c. Examples of Directional Procedure
 - (1) A non-executive message to one ship, direct.

<u>F51 makes</u>	<u>D63 makes</u>
<u>D63 (until answered)</u>	K
<u>BT</u>	Flash
ALPHA	Flash
DELTA	Flash
<u>Six</u>	Flash
<u>BT</u>	Flash

UNCLASSIFIED

ACP130(A)

1515Z	Flash
K	R
Flash	

- (2) A non-executive message to one ship passed by a specific relay.

<u>D63 makes</u>	<u>D51 makes</u>	<u>D48 makes</u>
D51 (until answered)	K	
T	Flash	
R	Flash	
1Ø21ØØZ	Flash	
FM	Flash	
D63	Flash	
TO	Flash	
<u>D48</u>	Flash	
<u>BT</u>	Flash	
ALPHA	Flash	
DELTA	Flash	
Six	Flash	

<u>D63 makes</u>	<u>D51 makes</u>	<u>D48 makes</u>
<u>BT</u>	Flash	
K	R	
Flash	D48 (until answered)	K
	R	Flash
	1Ø21ØØZ	Flash
	FM	Flash
	D63	Flash
	TO	Flash
	<u>D48</u>	Flash
	<u>BT</u>	Flash
	ALPHA	Flash
	DELTA	Flash
	Six	Flash
	<u>BT</u>	Flash
	K	*R
	Flash	

* If a message requires checking, a flash may be given for the K and an R transmitted when ready to receipt.

603. NON-DIRECTIONAL PROCEDURE

- a. This procedure permits one station to transmit to a number of other stations simultaneously by means of a light showing over a wide area. It is seldom used at night in wartime owing to danger of enemy interception. It may be used by day or night in circumstances where the risk is negligible. The procedure prescribed for non-directional flashing light differs from that laid down for directional flashing light as follows:
- (1) The call may consist of a collective call sign, or a number of call signs, repeated until answered by all receiving stations.
 - (2) Each receiving station answers by transmitting a continuous series of Ks until the calling station, seeing that all receiving stations are answering, stops calling, waits a short time, then starts transmitting the message. Where practicable receiving stations shall use a directional light of minimum brilliance.
 - (3) Where repeating ships are employed, they will repeat the originator's transmissions word by word as received.
 - (4) During transmission of the message, all receiving stations keep their lights out. Should a receiving station miss a portion of the message, that station is to request a repetition in the normal manner upon completion of the transmission. A station which is repeating the message as received, and who misses a portion may substitute the operating signal ZEP* for the missing portion and proceed with the transmission. When the missing portion is obtained, it is transmitted in the form of a correction.
 - (5) Receiving stations, after checking, receipt for the message by making RRRR.
 - (6) When the prosign F is used in non-directional procedure no ship is to make any response to this call or to receipt for the message. Ships that miss the transmission or any portions thereof may request repetitions by directional flashing light from adjacent ships. In requesting such repetitions, ships should bear in mind the danger of disclosing the tactical composition of the formation.
 - (7) The separative sign is used between coded groups.

*ZEP means "This message (or message) was incompletely received. Each word or group missed, which is indicated by position of ZEP in the message, will be forwarded as soon as obtained."

b. Example of Non-Directional Procedure

The example below illustrates non-directional procedure using repeating ships. Ø1 (OTC) transmits a priority message to all ships present.

<u>Ø1 makes</u>	<u>Repeating Ships makes</u>	<u>Receiving Ships makes</u>
2 - P (until answered)	2 - P (until answered)	Ks (or hoist DESIG if using DSL - see sub para c)
- P -	- P -	
<u>211357Z OCT</u>	<u>211357Z OCT</u>	
<u>BT</u>	<u>BT</u>	
MY 211247Z OCT	MY 211247Z OCT	
Operation	Operation	
postponed one	postponed one	
<u>hour</u>	<u>hour</u>	
<u>BT</u>	<u>BT</u>	
K	K	

c. Special Daylight Signalling Equipment

- (1) Where a special non-directional daylight signalling lantern (DSL) is fitted, the procedure to be employed by the transmitting station is the same as that prescribed for non-directional procedure.
- (2) Receiving stations answer by hoisting DESIG. Repetitions are obtained in the same manner as for non-directional procedure. The entire message is finally received for by hauling down DESIG.

604. **CALLING**

- a. In visual communication the identity of the calling station is usually apparent, and it is necessary only to gain the attention of the station being called. This is normally done by making, until answered, the call sign of the station being called. When it is desirable to identify the calling station, the full call is used. This consists of the call sign of the station called and when answered, the prosign DE, and the call sign of the calling station on occasions, e.g., when using no response procedure, it may be necessary to transmit the full call before or without being answered. (See paragraph 607.d. for the latter.)

EXAMPLES:

Abbreviated call	C33 (until answered)
Full call	C33 (until answered) DE D46

OrC33 DE D46

- b. Collective or multiple call may be employed as required.
 - (1) A collective call consists of a single call sign representing more than one station,
e.g., D SQUAD 4.
 - (2) A multiple call may consist of two or more individual or collective calls,
e.g., D SQUAD 3 D56.
 - (3) Both collective and multiple calls may be followed by the prosign DE and the call sign of the calling station.
- c. Call signs and address groups which may be used in the heading or ending are:
 - (1) Visual call signs from Chapter 2.
 - (2) Call signs from ACP 113.
 - (3) Address groups from ACP 100.
- d. The call may serve as the address. When abbreviated calls are used, it is to be assumed that the message is addressed from and to the Commanding Officer. When this is not the case, a full call, address component or the call sign of the authority addressed is to be used.
- e. In examples throughout this book the use or absence of calls, full or abbreviated, may be altered in practice, depending on the circumstances.

605. **ANSWERING AND RECEIPTING**

- a. The answer normally consists of the prosign K. (In non-directional procedure, except as prescribed in e. below the stations called answer by transmitting a continuous series of Ks until the calling station, seeing that all stations are answering, stops calling, waits a short pause, and continues with the transmission.) The calling station may flash for the series of Ks from each unit until all units have responded.
- b. If necessary to distinguish which of several stations is being answered, the prosign K should be preceded by the call sign of the station answered.

- c. Where more than one station is being called in the same direction or during low visibility, it may be necessary for the answering station to indicate its own identity when answering. This is done by transmitting the prosign DE followed by own call sign and prosign K. This method is also used in answer to the prosign AA. (See paragraph 607.a for the latter.)
- d. When required, a full answer consisting of the call sign of the calling station, and the prosign DE followed by the call sign of the station answering may be employed.
- e. A call received from a station using special non-directional Daylight Signalling Equipment will be answered by hoisting DESIG. DESIG is used in the same manner as ANS in paragraph 710.c.(2). (See paragraph 603.c-(2).)
- f. In flashing light procedure when giving an immediate receipt to a message in response to the prosign K, the prosign R is used singly without an ending sign K or AR

606. RELAYING INSTRUCTIONS

- a. When relaying responsibilities are automatic, relaying instructions need not be inserted in the transmission instructions.
- b. The prosign T is to be used when signals/messages are passed through a relay when relaying responsibilities are not automatic and the originator requires no report of delivery. The address component is mandatory.
- c. The prosign L is to be used when the originator requires relaying ships to report through the chain of visual responsibility ~~when~~ the message has been delivered.
- d. The prosign L is not to be used in the transmission instructions of executive method messages. The prosign L must however, be passed in to the originator by relaying ships when the text of the executive method message has reached the last ship in the chain of visual responsibility. It is not to be passed in for the executive signal nor for messages where no response procedure is used.
- e. The prosign L must be passed to the originator by a ship, which relays an emergency alarm signal to the Officer in Tactical Command (OTC).

607. SPECIAL PROCEDURES

- a. Calling an unknown station.
 - (1) The identity of a station may be established by using the prosign AA, unknown station call.

EXAMPLE: The identity of each station is unknown to the other.

<u>PACM makes</u>	<u>GCCM makes</u>
AA (until answered)	DE
Flash	GCCM
Flash	K
DE	Flash
<u>PACM</u>	Flash
AR (or proceeds with message)	Flash

b. Exchanging identities with Senior Officer Present Afloat (SOPA).

- (1) When prescribed, ships on entering port will exchange identities with the SOPA. This will be done in the special procedure described below. If the ship entering has a message for SOPA it will transmit this message after identities have been exchanged. Normal procedure will then be used.

EXAMPLE:

<u>PACM makes</u>	<u>GKYD (SOPA) makes</u>
DE PACM (at intervals)	PACM
K	DE
Flash	<u>GKYD</u>
Flash	AR (or proceeds with message)
Flash	

If PACM has a message for SOPA, SOPA will be called in the normal way.

- (2) When it is desired to indicate both flag or unit commander's call sign and the ship's call sign, slant (XE) should be inserted between them and transmitted in the same manner as the single call sign, and sent as one group.
- (3) Exchanges of identities with the senior officer present shall be relayed by intervening stations when necessary. operating signals are provided to facilitate this relay with meanings as follows:

ZOL "I will relay your call sign to SOPA, whose call sign is....."

ZGG3 "Call sign of incoming vessel is....."

EXAMPLE:

<u>NJGQ makes</u>	<u>PACM makes</u>	<u>GKYD (SOPA) makes</u>
DE NJGQ (at intervals)	NJGQ	
K	DE	
Flash	PACM	
Flash	ZOL	
Flash	<u>GKYD</u>	
Flash	<u>AR</u>	
Flash	GKYD (until answered)	K
	ZGG3	Flash
	<u>NJGQ</u>	Flash
	<u>AR</u>	Flash

c. Double-flash Procedure.

- (1) Double - flash procedure is for use when a recorder is not available. A station called desiring to use double-flash procedure will transmit the appropriate operating signal meaning "Use double-flash procedure." An operator receiving a message using double - flash procedure will flash to indicate the receipt of a word or group and will then flash again to indicate that the group is recorded and that he is ready to receive the next word or group.

EXAMPLE:

<u>D8Ø3 makes</u>	<u>D836 makes</u>
D6 (until answered)	ZJJ
<u>Flash</u>	K
BT	Flash (for prosign)
	Flash (when recorded)
Send	Flash (for word)
	Flash (when recorded)
(Proceeds with message)	

ZJJ means "Use double - flash procedure."

d. No Response Procedure.

UNCLASSIFIED

ACP130(A)

- (1) The prosign F transmitted four times (repeated as necessary) preceding the call indicates that stations called are not to answer the call or receipt for the message. The message is to be transmitted twice, but the prosign F is not to be transmitted four times preceding the call of the second transmission.
- (2) When this procedure is used with a collective call sign, individual stations relay by the same procedure in accordance with their visual responsibilities, except that if made by non-directional light the stations receiving the message are not to repeat it.
- (3) The prosign F, when used, is to be included in the transmission instructions of plaindress or codress messages.

EXAMPLE A: D36 transmits a message to D72.

FFFF FFFF D72 DE D36* - F - R - 12Ø745Z GR8 BT TEXT BT - IMI
D72 DE D36* - F - R - 12Ø745Z GR8 BT TEXT BT- AR

*The call may be omitted when no confusion could result.

EXAMPLE B: D87 transmits a message by directional light to three ships D63, D67 and D74 using the collective call sign D DIV 1.

<u>D87 makes</u>	<u>D63 makes</u>	<u>D67 makes</u>	<u>D74 makes</u>
FFFF			
D DIV 1			
- F -	FFFF		
BT	D DIV 1		
SIERRA	- F -	FFFF	
<u>YANKEE</u>	etc.	D DIV 1	
BT		- F -	No response
<u>Ø315Z</u>		etc.	
IMI			
D DIV 1			
- F -			

<u>D87 makes</u>	<u>D63 makes</u>	<u>D67 makes</u>	<u>D74 makes</u>
BT			
SIERRA			
YANKEE			
BT			
<u>Ø315Z</u>			

AR

NOTE: No ship will make any response.

e. Alarm Procedure for Enemy Reporting.

- (1) Emergency alarm signals may be made by normal abbreviated procedure or by this special alarm procedure. In alarm procedure there is no call, the text being flashed continuously until answered by R. The precedence prosign, the position of the reporting station and the date-time group are omitted. When used, such a report should be followed by an amplifying report containing the position and any other data available.

EXAMPLE A: Reporting ship R62 is in direct visual communications with the OTC, R64

<u>R62 makes</u>	<u>R64 makes</u>
EMERG GOLF (until answered)	R
DE	Flash
<u>R62</u>	Flash
<u>AR</u>	Flash

EXAMPLE B: Reporting ship D56 relaying through C64 to the OTC, R23. When an alarm report is passed through a relay, the call sign of the originator and the relaying ship are to be indicated.

<u>D56 makes</u>	<u>C64 makes</u>	<u>R23 makes</u>
EMERG GOLF (until answered)	R	
DE	Flash	
<u>D56</u>	Flash	
<u>AR</u>	Flash	
	EMERG GOLF (until answered)	R
	DE	Flash
	D56	Flash
	<u>C64</u>	Flash
	<u>AR</u>	Flash
	L	
Flash		

f. Special Visual Prosign OL.

The special visual prosign OL is used to tell the receiving station to show a steady dim light. If a station is obviously having difficulty in keeping its light properly trained, the receiving station may be directed to show a steady dim light as a training mark. The flashes to indicate reception of the message must be made slightly brighter, or if necessary, a second light may be used.

g. Method of Synchronizing Time.

- (1) The procedure in this. sub-paragraph is to be used for requesting and transmitting timing signals by flashing light.
- (2) The request for a timing signal is to be made by abbreviated service message employing the operating signal meaning "Request a timing signal now (or at.....)."
- (3) The intention to make a timing signal may be conveyed in advance by abbreviated service message employing the operating signal meaning "Stand by" followed by that meaning "Timing signal will be transmitted now (or at.....)."
- (4) The timing signal is to be transmitted as an abbreviated service message employing the operating signal meaning "Timing signal will be transmitted now (or at).- The operating signal is to be followed by the four figure group plus the zone suffix, indicating the time and a five second flash repeated by station called. The five second flash is to be completed exactly at the time indicated for the check.
- (5) Stations concerned, which have received the check correctly are (if instructed to do so) to give a receipt in the normal manner. Any stations, which fail to receive the timing signal correctly must request a further check by operating signal.

EXAMPLE: D46 conveys intention to DØ6 to make a timing signal.

<u>D46 makes</u>	<u>DØ6 makes</u>
DØ6 (until answered)	K
ZUJ	Flash
ZUA	Flash
Ø845 (time zone)	Flash
K	R
Flash	

D46 makes a timing signal

DØ6 (until answered)	K
ZUA	Flash
Ø845 (time zone)	Flash
<u>5</u> second flash	5 second flash
AR	Flash

ZUJ means "Stand by."

ZUA means "Timing signal will be transmitted now (or at.....)."

- (6) Flag TANGO, followed by two or four numerals, also signifies a time check.

EXAMPLE:

<u>D46 makes</u>	<u>DØ6 makes</u>
<u>DØ6</u> (until answered)	K
<u>IX</u>	Flash
Flag T	Flash
1645 (time zone)	Flash
K	R
Flash	

(to execute)

DØ6 (until answered)	K
IX's	IX's
<u>5</u> second flash	5 second flash
AR	Flash
	F

h. Abbreviated Flashing Light Directional Procedure

In order to improve the transmission speed of messages consisting of signal groups, the following abbreviated flashing light directional procedures are to be used:

- (1) All alphabetical and numeral flags and numeral pennants are to be transmitted as their morse symbol.
- (2) Tack is to be transmitted as a short break (II)
- (3) A flash is to be transmitted by the receiving station as follows:

- (a) For each prosign, callsign, special flag or pennant.
- (b) For each series of numbers making up a basic group (e.g. TA 117)
- (c) For each series of numbers following a special flag or pennant.
- (d) For each single letter preceding or following a special flag or pennant.
- (e) For each suffix number of letter.

EXAMPLE: F11 transmits G - Ap3p7 - CORPEN PAPA 165 - SPEED 11

<u>Fp1p1</u>	<u>Ap3p7</u>
G	Flash
II	Flash
PT	Flash
A37	Flash
II	Flash
CORPEN	Flash
P	Flash
165	Flash
II	Flash
SPEED	Flash
11	Flash
K	R
Flash	

608. INDICATING PRECEDENCE IN CALLS

Precedence may be indicated in the call when using an abbreviated or full call, as shown in paragraph 408.

609. TRANSMISSION OF SIGNALS FROM A SIGNAL BOOK

- a. In the heading.
 - (1) Letters will be sent as Morse letter symbols.
 - (2) Numerals and numeral pennants will be sent as Morse numeral symbols.
- b. In the text.
 - (1) Letters and numerals comprising of signal groups will be transmitted as their morse symbol and not spelt out.

- (2) Call signs will be transmitted in accordance with paragraph 206.b.
- c. At the discretion of the OTC, when conditions and operators' capabilities permit, all the alphabetical and numeral flags and numeral pennants comprising a signal may be transmitted as their Morse symbols to expedite signalling.

610. RECEIVING STATION REPEATING DIFFICULT WORDS

The receiving station may be instructed to repeat difficult or important words or groups in the text by the use of the prosign G as shown below. The more general use of the prosign G is given in paragraph 317.

EXAMPLE:

<u>Transmitting station makes</u>	<u>Receiving station makes</u>
FOR	Flash
PLAN	Flash
2P3/C5	Flash
G	Flash
	2P3/C5
C (or repeats group if it was repeated back incorrectly) (continues with text)	Flash

611. EXECUTIVE METHOD

- a. The executive method is used when it is desired to execute a signal at a certain instant, for example to ensure that two or more units take action at the same moment. While the executive method is usually associated with signals from a signal book, it may be used, when appropriate, for plain language messages.
- b. There are two types of executive methods:
 - (1) Delayed executive method, in which stations receipt for the message and the executive signal is made in a later transmission.
 - (2) Immediate executive method, in which the executive signal is made in the ending of the original message. Thus, stations are unable to give receipts before the message is executed.
- c. Only abbreviated plaindress messages may be employed with the executive method.
- d. Executive method messages do not carry a time group.

- e. A message which requires a signal of execution carries the prosign IX immediately before the first BT.
- f. When using the Executive Signal, IX (5 second flash), the IX is effectively "stand by" and should be repeated as often as necessary to ensure that all ships have received the stand by and are awaiting the order to execute. The moment of execution will be the completion of the 5 second flash. In both directional and non-directional procedure, except when using DSL, all ships repeat the IX being made to ensure the signal is ready for execution and repeat the executive signal (5 second flash) to ensure simultaneous execution.
- g. The Executive Signal, XI (5 second flash), alone after a call means "Execute all unexecuted messages transmitted by this station (by executive method) to the same call." The call may be omitted if not confusion could result.
- h. Identification is required if:
 - (1) A portion of a message or one of several unexecuted messages is to be executed at that time.
 - (2) A considerable time has elapsed between the transmission of the message and time to execute.

B23 has sent to all ships by non-directional method:

2 DE B23 IX BT FORM ONE TACK SPEED TWO FIVE BT K

- (a) To execute SPEED TWO FIVE only, the transmission would be:

2 DE B23 SPEED TWO FIVE XI - (5 second flash) AR

- (b) To execute the remaining portion the transmission would be:

2 DE B23 IX's (5 second flash) AR

- (c) To have executed the entire transmission after a considerable time lapse the transmission would have been:

2 DE B23 FORM ONE TACK SPEED TWO FIVE IX's (5 second flash) AR

NOTE: The, absence of BTs in (a) and (c) shows that the message to be executed is not a new message.

- i. Requests for repetitions, corrections or verifications of the texts of signals taken from a naval signal book must be for the entire text or those portions separated by TACK. The following applies:
 - (1) BT to TACK - first BT to first TACK
 - (2) TACK to TACK - first TACK to next TACK
 - (3) TACK to BT - first TACK to final BT
- j. When it is necessary to reference a portion of a signal where the above will not suffice, then include with the TACK only enough amplifying information (suffix, call sign etc.) as necessary to positively identify the portion referred to.

612. **EXAMPLES OF DELAYED EXECUTIVE METHOD - DIRECTIONAL PROCEDURE**

- a. C69 transmits direct to D35.

<u>C69 makes</u>	<u>D35 makes</u>
<u>D35</u> (until answered)	K
XI	Flash
BT	Flash
TURN	Flash
STBD	Flash
<u>FOUR</u>	Flash
BT	Flash
K	R
Flash	

(to execute)

<u>C69 makes</u>	<u>D35 makes</u>
D35 (until answered)	K
IX's	IX's
<u>5</u> second flash	5 second flash
AR	Flash

- b. DIV D 5 transmits an executive method message to D DIV 5 by directional light.

<u>DIV D 5 makes</u>	<u>D32 makes</u>	<u>D72 makes</u>
----------------------	------------------	------------------

1	K	
<u>1</u>	1	K
<u>XI</u>	Flash	
	IX	Flash
<u>BT</u>	Flash	
	BT	Flash
CORPEN	Flash	
	CORPEN	Flash
STBD	Flash	
	STBD	Flash
NINE	Flash	
	Nine	Flash
<u>BT</u>	Flash	
	BT	Flash
K	R	
Flash	K	
	Flash	R
	L	
Flash		
* (to execute)		
IX's	IX's	IX's
<u>5</u> second flash	5 second flash	5 second flash
<u>AR</u>	Flash	
AR	Flash	

*NOTE: The executive signal may be preceded by a call in the event of a delay in receipt of the original transmission.

613. **EXAMPLE OF DELAYED EXECUTIVE METHOD - NON-DIRECTIONAL PROCEDURE**

<u>R38 makes</u>	<u>Repeating ships makes</u>	<u>Receiving ships makes</u>
2 (until all answer)	2 (until all answer)	Ks (or hoist DESIG if by DSL)
IX	IX	
BT	BT	
SPEED	SPEED	
TWO	TWO	
FIVE	FIVE	
BT	BT	

K DESIG if by DSL)	K	RRRR (or haul down
Flash	L	
(to execute)		
*2 (until all answer)	2 (until all answer)	K's (or rehoist DESIG if by DSL)
IX's	IX's	IX's (unless transmission by DSL)
5 second flash	5 second flash	5 second flash (or haul down DESIG if by DSL)
<u>AR</u>	<u>AR</u>	

*Second call-up may be omitted if no confusion could result.

614. **IMMEDIATE EXECUTIVE METHOD**

a. The rules for immediate executive method are:

- (1) The text is to be sent twice, separated by IMI. The executive Signal, IX 5 second flash), is made at the end of this transmission.
- (2) As receipts cannot be obtained before execution of the message, the use of immediate executive method must be authorized by the officer originating the message.
- (3) Directional procedure may be used with a single ship. Non-directional procedure must be used if signalling two or more ships at night. Immediate executive method is not normally used during daylight, when signalling two or more ships, unless the originating ship is fitted with DSL.
- (4) It is NOT to be used with directional flashing light when employing no response procedure.

EXAMPLE	<u>R62</u> makes	<u>C41</u> makes
	C41 until answered	K
	IX	Flash
	BT	Flash
	SPEED	Flash
	TWO	Flash
	<u>ZERO</u>	Flash
	<u>IMI</u>	Flash

SPEED	Flash
TWO	Flash
ZERO	Flash
BT	Flash
IX's	IX's
5second Flash	5 second Flash
K	R
Flash	

615. **EXAMPLE OF IMMEDIATE EXECUTIVE METHOD**

- a. B3 transmits TURN STBD NINE by immediate executive methods using non-directional procedure.

<u>B23 makes</u>	<u>Repeating ships makes</u>	<u>Receiving ships makes</u>
2 (until all answer)	2 (until all answer)	Ks (or hoist DESIG if by
<u>DSL</u>)		
<u>IX</u>	<u>IX</u>	
BT	BT	
TURN	TURN	
STBD	STBD	
NINE	NINE	
IMI	IMI	
TURN	TURN	
STBD	STBD	
NINE	NINE	
BT	BT	
IX's	IX's	X's (unless transmission is by DSL)
5 second flash	5 second flash	5 second flash (or haul down DESIG f by DSL
K	K	RRRR (unless transmission is by DSL)

- b. R38 transmits CORPEN STBD NINE by the IMMEDIATE EXECUTIVE method.

<u>R38 makes</u>	<u>C46 makes</u>
<u>C46 (until answered)</u>	K
<u>IX</u>	Flash
BT	Flash
CORPEN	Flash

STBD	Flash
<u>NINE</u>	Flash
IMI	Flash
CORPEN	Flash
STBD	lash
<u>NINE</u>	Flash
<u>BT</u>	<u>Flash</u>
IX IX IX	IX IX IX
<u>5</u> Second Flash	5 Second Flash
AR	Flash

616. **EXAMPLE OF VERIFICATION AND CORRECTION - EXECUTIVE METHOD MESSAGES**

- a. R38 has made by delayed executive method to all ships TURN STBD TWO TACK SPEED EIGHT.

R21 requests verification of TURN STBD TWO

<u>R21 makes</u>	<u>R38 makes</u>
<u>R38</u> (until answered)	K
BT	Flash
J	Flash
TURN	Flash
STBD	Flash
<u>TWO</u>	Flash
BT	Flash
1358Z	Flash
K	R
Flash	

R38 confirms with his Commanding Officer that the message is correct as originally transmitted:

<u>R38 makes</u>	<u>R21 makes</u>
R21 (until answered)	
<u>BT</u>	K

C	Flash
TURN	Flash
STBD	Flash
TWO	Flash
<u>BT</u>	Flash
1405Z	Flash
K	R
Flash	

- b. If the message or portion of the message is found to be incorrect, the whole message or portion must be cancelled to all addressees and a new message transmitted. (The new message may be made and executed before the incorrect message is cancelled in those cases when speed is vitally important.)

<u>R38 makes</u>	<u>Receiving ships makes</u>
2 (until all answer)	
<u>BT</u>	Ks
NEGAT	
TURN	
STBD	
TWO	
BT	
1458Z	
K	
	RRRR
2 (until all answer)	
	Ks
<u>IX</u>	
<u>BT</u>	
TURN	
PORT	
<u>TWO</u>	
<u>BT</u>	
K	

RRRR

The two signals TURN PORT TWO and SPEED EIGHT are unexecuted and may be executed together or singly in the normal manner.

617. CANCELLING MESSAGES

- a. Once the executive signal has been made, a message cannot be cancelled.
- b. An executive method message awaiting execution can only be cancelled by a separate non-executive method message.
- c. To cancel all messages awaiting execution, the prosign NEGAT is transmitted. NEGAT preceded by a call cancels all executive method messages addressed to that call.

EXAMPLE:

2 DE C36 BT NEGAT BT 1512Z K

- d. To cancel only one, or a portion of several messages awaiting execution, the prosign NEGAT must be followed by identification data, consisting of a repetition of the text, which it is desired to cancel.

EXAMPLE: The following message is awaiting execution:

2 DE C23 IX BT FORM ONE TACK TURN STBD ONE EIGHT BT K

To cancel TURN STBD ONE EIGHT, C23 transmits:

2 DE C23 BT NEGAT TURN STBD ONE EIGHT BT 1212Z K (or AR)

- e. When a message is awaiting execution and a portion of it has been cancelled or executed only the remainder of that message is considered to be outstanding.

618. FLASHING WITH AIRCRAFT

- a. When flashing with aircraft, the following points must be borne in mind:
 - (1) Flashing is only possible when the aircraft is occupying certain positions relative to the line of sight from the station with which flashing is taking place; consequently, owing to the rapid movement of the aircraft, the signaler may find that the time that the aircraft is in a favorable signalling position is very short.

- (2) The signaler in an aircraft may not have anyone to write down the message for him. He may have to read the whole of the message, and write it down from memory, or write down each word before sending a flash. It may therefore be advisable with long messages to use double-flash procedure.
 - (3) The aircraft should be maneuvered into a favorable position for the signaler to have an unobstructed view for as long a period as possible.
 - (4) Accurate training of the light at all times by the sending operator is of the utmost importance.
- b. Calling.
- (1) Aircraft are called by means of AA, the unknown station call.
 - (2) Many aircraft cannot signal by flashing and an answer should not always be expected. If no answer is seen, the message is to be made through at least twice, repetitions being preceded by IMI. Receipt may be indicated by the aircraft rocking its wings.

CHAPTER 7

SEMAPHORE

701. **GENERAL**

- a. Standard semaphore apparatus consists of two hand flags, generally 15 to 18 inches square, of design similar to either flags OSCAR or PAPA, attached to staffs about 22 inches long.
- b. The standard semaphore characters are illustrated in Figure I.

702. **TRANSMITTING**

- a. Care is to be exercised in selecting the position from which to send a semaphore message, in order that a good background may be obtained.
- b. The characters are to be formed in the same plane as the sender's shoulders with staffs at their full extent, forefingers along the staffs. When making the front sign, the flags should be crossed in front of the body.
- c. A distinct pause is to be made at each character according to the rate of sending. When transmitting prosigns, operating signals and abbreviations, this pause is to be of double duration. A double duration pause at each character is also recommended when transmitting coded groups.
- d. The front sign is made at the end of each word, group, prosign or operating signal. Where double letters occur, the arms are to be dropped to the front sign after the first letter is made, and then moved to the second letter without pausing.

703. **RATE OF SIGNALLING**

- a. Semaphore messages should be transmitted at a rate consistent with the capabilities of the receiving operator.
- b. Semaphore messages being transmitted to more than one receiving station should always be made at a moderate rate by the originating ship and by ships relaying.

704. **READING**

- a. The direction sign shows the direction of transmission.
- b. The characters as a general rule are made facing the ships called.

705. **SIGNALLING PROSIGNS AND OPERATING SIGNALS**

Prosigns and operating signals are signaled as groups, e.g., FM, IMI, QRK.

706. **NUMERALS**

Numerals occurring in all components of a semaphore message shall be spelled out. If it is desired that numerals be recorded as digits they shall be preceded and followed by the numerals sign, except in the heading and ending where numerals or numeral pennants are always recorded as digits.

707. **TRANSMISSION OF SIGNALS FROM A SIGNAL BOOK**

- a. In the heading.
 - (1) Letters will be sent as characters.
 - (2) Numerals or numeral pennants will be spelled out but recorded as digits.
- b. In the text.
 - (1) Letters and numerals comprising a signal group will be spelled out.
 - (2) Call signs will be transmitted in accordance with paragraph 206.b.
 - (3) The use of the executive method by semaphore is not authorized.

708. **SPECIAL CHARACTERS**

- a. Answering Sign - Used as an answer to a call. If necessary, the answering sign may be preceded by a call sign to denote the station answered.
- b. Attention Sign - Used as a preliminary call by semaphore and to establish communication.
- c. Direction Sign - Used after the attention sign to indicate the direction of transmission.
- d. Front Sign - See subparagraph 702.d.
- e. Numeral Sign - Used before and after each group of numerals, or groups of mixed letters and numerals in the text, which are to be recorded and counted as a single group consisting of letters and digits.

UNCLASSIFIED

ACP130(A)

- f. Separative Sign - The separative sign in semaphore is a special character made by sending the characters II as one group. It is used in accordance with paragraph 321.
- g. The following examples illustrate the use of these signs which are indicated as follows:

Attention	-	Asterisk (*)	Numeral	-	Number Sign (#)
Front	-	Colon (:)	Direction	-	Percent Sign (%)
Separative	-	Hyphen (-)			

- (1) Message transmitted in abbreviated form. Message is addressed to C19 and was originated and transmitted by D26:

* : % : - :

FM : D : # TWO : SIX #: - :

TO : C : # ONE : NINE #

BT :

SEARCH : AREA : ONE : TWO : BRAVO : COMPLETING : NOT :
LATER :

THAN : ONE : EIGHT : ZERO : ZERO : ZULU : # :

BT :

SEARCH : AREA : ONE : TWO : BRAVO : COMPLETING : NOT :
LATER :

THAN : ONE : EIGHT : ZERO : ZERO : ZULU : # :

BT : ONE : TWO : FIVE : ZERO : Z :

K :

Recorded as:

FM Dp2p6 -
TO Cplp9
BT
SEARCH AREA ONE TWO BRAVO COMPLETING NOT LATER
THAN
18ØØZ BT 125ØZ K

- (2) Message transmitted in plaindress form. Message is addressed to D76 and F43 and was originated and transmitted by R72:

* : % :

- : P : - : ONE : SIX : ONE : SEVEN : ONE : EIGHT : Z : - :

FM : R : SEVEN : TWO : - :

TO : D : SEVEN : SIX : - :
 INFO : F : FOUR : THREE :
GR : FOUR :
 BT:
AVOLO : TSAPI : HNUMY : ETERA :
 BT:
 K :
 Message recorded as:
 - P - 161718Z -
 FM R72 -
 TO D76 -
 INFO F43
GR4
 BT
AVOLO TSAPI HNUMY ETERA
 BT
 K

- (3) Groups containing mixed letters and numerals in the text are to be counted as one group.

Transmitted: LIMA : FOUR : HOTEL : TWO : # :
 Written: L4H2

- (4) Groups containing punctuation symbols authorized in paragraph 106.a.(2), in the text are to be counted as one group.

Transmitted: # : ONE : TWO : FIVE : XE : THREE : # : AND : XE :
 OR : # : FIVE : SIX : SEVEN : XE : ALFA : BRAVO : EIGHT : AAA :
 SIX : # :

Written: 125/3 and/or 567/AB8.6 (3 groups)

NOTE: When checking group count (see paragraph 413.b), groups such as those shown in examples (3) and (4) above will be indicated by the first effective letter or numeral in the group.

709. SPECIAL SEMAPHORE ABBREVIATIONS

- a. Move Signs - Used by receiving station to direct the sender to move to a better sending position. They are:

MD Move down.

ML Move to your left, as you face me.
 MR Move to your right, as you face me.
 MU Move up.

- b. The abbreviation SEM may be used in calling and answering by flashing that a semaphore message will follow, or that the transmitting station is to use semaphore.

710. CALLING

- a. A call by semaphore is made by transmitting the call sign of the station called, or if practicable by just making the attention sign. It may be answered either by making the answering sign C by semaphore, or by transmitting the prosign K by flashing light or by hoisting ANS.
- b. The call for a semaphore message may be made by flashing light, in which case it is answered by flashing light. After being answered by flashing light, the transmitting station then indicates that a semaphore transmission will follow by the use of the abbreviation SEM.
- c. The call for a semaphore message may be made by flaghoist as follows:
- (1) The calling station hoists the call signs of the station called above flag JULIETT. When calling all ships and stations within visual range flag JULIETT may be used alone. DESIG hoisted below JULIETT indicates that a priority message awaits transmission. If it is desired to indicate any higher precedence the appropriate precedence prosign may be hoisted below DESIG.
 - (2) The receiving ship hoists the call sign of the transmitting station above ANS at the dip when seen, close up when ready to receive, and hauls down to indicate receipt. When no confusion could arise, the call may be omitted.

711. REPETITIONS

The receiving station shall allow the transmitting station to complete the transmission of the message before requesting a repetition. Repetitions are obtained as described in Chapter 4.

712. INTERRUPTION OF TRANSMISSION OR RECEPTION

The transmitting station may dip the call signs of the receiving stations to indicate that he is required to wait; the receiving stations should then dip their answering hoists until the transmitting station again hoists the call signs close up. The transmitting station may also use the prosign AS; by semaphore as described in Chapter 3. The receiving stations may dip their answering hoists to indicate that they are unable to receive.

713. **RECEIPTING**

- a. Receipt for a semaphore message is given by:
 - (1) Making R by semaphore or flashing light.
 - (2) Hauling down the answering hoist.

714. **EXECUTIVE METHOD BY SEMAPHORE**

The use of the executive method by semaphore is not authorized.

715. **RELAY**

- a. Where relay is involved, relaying stations should endeavor to pass on the message as rapidly as possible and should not wait for the original transmitting station to complete the message before commencing its retransmission.
- b. A station which is repeating the message as received and which misses a portion may substitute the operating signal ZEP* for the missing portion and proceed with the transmission. When the missing portion is obtained it is transmitted in the form of a correction.

*ZEP means "This message (or message.....) was incompletely received. Each word or group missed, which is indicated by position of ZEP in the message, will be forwarded as soon as obtained."

716. **EXAMPLES**

- a. When calling and answering by flaghoist.

Transmitting Station

Hoists call signs of units for which message is intended over JULIETT. If calling all ships in visual range JULIETT alone may be hoisted

Receiving Stations

Hoists call sign of transmitting station over ANS at the dip as soon as seen and close up when ready to receive. ANS alone may be used when no confusion will result.

When all stations have hoisted ANS close up commences transmission. If transmission is temporarily interrupted call should be dipped until ready to resume.

Transmitting Station

Upon completion of single message hauls down. If more than one message makes B K by semaphore, dips hoist until ready to send second message. Hoists call close up and resumes transmission. (see paragraph 309b)

Hauls down on completion of transmission of last message.

Receiving Stations

Keeps ANS hoisted close up while receiving, dips hoist if unable to receive for any reason.

Hauls down on receipt of single message. If more than one message dips hoist to receipt for the first message and close up to indicate readiness for next. Request for repetitions and relaying of first message may be initiated at this point if normal transmission is not interrupted. (see paragraph 309b)

Dips hoist to indicate receipt of last message. Hauls down when relaying responsibilities completed. No ship will haul down until all messages are completely received.

- b. When calling and answering by flashing light (one ship only).

Transmitting Station

Receiving Station

Call by flashing light

Makes K

SEM

Makes K

Proceeds with message using Semaphore

Receipts by light or semaphore.

- c. When calling and answering by semaphore.

Transmitting Station

Receiving Station

Makes call by semaphore

Proceeds with message using Semaphore

Makes C by semaphore or K by light.

Makes R by semaphore or light.

UNCLASSIFIED

ACP130(A)

7-9
UNCLASSIFIED

Original

CHAPTER 8

FLAGHOIST

801. **FLAGS AND PENNANTS**

Flags and pennants to be used in flaghoist communication are shown on Plate II.

802. **CALL SIGNS, ADDRESS GROUPS AND SEQUENCE NUMBERS**

a. Call signs, address groups and sequence numbers may be used in conjunction with signals from the Allied Maritime Tactical Signal Book or national or regional defense organization publications to complete, amplify or vary the meaning of signals as follows:

- (1) To address ships, units or commands, in which case they precede the signal.
- (2) To indicate or denote ships, units or commands referred to in the meaning of the signal, in which case they follow the entire signal.

803. **MESSAGE CONSTRUCTION**

A flaghoist message contains two parts - the heading and the text.

804. **THE HEADING**

The heading precedes the text and usually consists of only action addressees, although it may include information and exempted addressees.

805. **OMISSION OF ADDRESS**

- a. The address may be omitted under the following circumstances:
- (1) By the officer in Tactical Command (OTC) (in port the Senior Officer Present Afloat (SOPA) on signals addressed to all ships.
 - (2) By ships addressing the OTC who are in direct visual communication with him and no relay will be required, provided no confusion will result.
 - (3) By ships or commands on emergency alarm signals addressed to the OTC. (See paragraph 816.)

806. **MODIFICATION OF HEADING**

- a. The heading of a flag signal may be modified by use of the four substitutes as follows:
- (1) **FIRST SUB** - over the call sign of the originator hoisted where best seen means: "The originator of this signal is Intervening ships relay this signal to the addressees or to the OTC if there is no addressee."
 - (2) **SECOND SUB** - in place of the address means: "For general information: no specific address; no answer required."
 - (3) **THIRD SUB** - preceding the address means: "This signal, in addition to being addressed to certain ships for action, is for general information and is to be relayed and answered as an 'all ships signal'."
 - (4) **FOURTH SUB** - at the yardarm means: "Accompanying signals are taken from ATP 2, VOL II" or national or regional defense organization publications.

807. **CONSTRUCTION OF HEADING**

- a. In constructing flaghoist calls, numerals are expressed by numeral pennants, except when numeral flags are specifically indicated.
- b. In flaghoist signalling information and exempted addressees are indicated by flag and the NEGAT pennant respectively. A tackline must often be used to separate call signs to avoid ambiguous combinations of flags in heading and must always be used to separate W from the call sign preceding and/or following it in the same hoist.
- (1) **Action and information** - In a flaghoist having both action and information addressees, the elements are arranged as follows:
 - (a) Call signs of action addressees.
 - (b) Flag W followed by call signs of information addressees.

EXAMPLE:

ACTION	All ships under my tactical command
INFO	Commander this Task Force
HOIST	p1 TACK W TACK p0p6

- (2) Exemption - To exempt a station from a collective call sign used in a flaghoist heading, the elements are arranged as follows:
- (a) Call signs of addressees.
 - (b) (b)NEGAT followed by call signs of exempted addressees.
(Exempted addressees do not answer and take no action.)

EXAMPLE:

ACTION	All ships under my tactical command
EXEMPT	Screen
HOIST	pl NEGAT p5

- (3) Information and exemption - To indicate simultaneously information and exempted addressees, the elements are arranged as follows:
- (a) Call signs of action addressees.
 - (b) Flag W followed by call signs of information addressees.
 - (c) NEGAT followed by call signs of exempted addressees.
(Exempted addressees do not answer and take no action.)

EXAMPLE:

ACTION	All ships under my tactical command
INFO	Commander this Task Force
EXEMPT	Screen
HOIST	pl TACK W TACK p0p6 NEGAT p5

- (4) Information - To indicate information addressees only, flag W followed by call signs of information addressees may be used.

808. **TEXT**

The text will consist of such prescribed signals and plain language as may be necessary to convey the subject matter expressed by the originator.

809. **USE OF TACKLINE (TACK)**

- a. A tackline is a length of halyard approximately six feet long; the exact length depends upon the size of flags in use. It is transmitted and spoken TACK, and is used:

- (1) To avoid ambiguity. It separates signals or groups of numerals which, if not separated, could convey a different meaning from that intended.
- (2) When, for the needs of a particular signal, the instructions order that a tackline be used.

810. **HOISTING FLAG SIGNALS**

- a. A flaghoist is said to be "close up" when its top is touching the block at the point of hoist. Signals when hoisted by the originating station are normally hoisted close up.
- b. A flaghoist is said to be "at the dip" (dipped) when hoisted three-fourths of the way up towards the point of hoist. Flaghoists made in answer to or to repeat the original signal are normally hoisted at the dip, until understood, when they are hoisted close up. Relaying ships are always to repeat Flaghoists at the dip until they have been acknowledged by ships for which they are responsible, after which they hoist the flaghoist close up. (See Paragraph 813.)
- c. A flaghoist is said to be "hauled down" when it is returned to the deck. The moment of hauling down is the moment of execution unless:
 - (1) Time of execution is otherwise indicated. (See paragraph 813.c.)
 - (2) Signal is to be acted upon as soon as understood. (See paragraph 813.d.)
 - (3) Signification of a signal indicates that it is to be executed on dipping. (See paragraph 813.e.)
- d. Best results are achieved in flaghoist communication when signals can be made as a single hoist and hauled down before another hoist is made. If the hoist is of such length that it cannot be displayed on one halyard, then it is to be broken where a tack would be normally inserted. If the complete signal cannot be made on three halyards it is usually advisable to make two or more hoists. When this is done, the heading is hoisted and kept flying close up while successive hoists are made.
- e. A Commander when making signals to the ships of his unit should, whenever possible, leave a superior position vacant for relaying the OTC's signals.
- f. To describe the relative positions of flags in a hoist the terms "above" and "below" are used.
- g. Signals should be hoisted at the minimum interval of time before they are to be executed and they should only be kept flying for as long as it is necessary for

ships to relay, and acknowledge the signals. The object of this is to ensure that flag hoisting will always be rapidly carried out whether the signal is made in an emergency or not, and that this channel of communication is kept clear for additional signals.

- h. Signals are to be hoisted where they can be most clearly seen by the receiving ships, if necessary hoisting the signal on both sides of the mast. Where the signification of the signal specifies the position of the flags, these instructions take precedence.
- i. Subject to the above principle, "all ships" signals are to be hoisted at a superior position and are to be answered/relayed at a superior position.
- j. When a display consists of two or more hoists, which will be flying at the same time, the hoists are to leave the deck in the order in which they are to be read.
- k. Whenever flags are hoisted, they are to be kept clear. If there is not enough wind to blow the flags out so that they can be easily read, the hoists should be kept on the move.

811. ORDER OF READING FLAG SIGNALS

- a. Order of flaghoists.
 - (1) Flags of a single hoist are to be read from the top down.
 - (2) Adjacent hoists are to be read from outboard in or from forward aft.
 - (3) When several flaghoists are displayed simultaneously, they are to be read in the following order:
 - (a) Masthead
 - (b) Triatic stay
 - (c) Starboard yardarm
 - (d) Port yardarm
- b. A flaghoist, which is to be read before another, which is flying at the same time, may be described as being in a "superior position." Conversely, a flaghoist, which is to be read after another is referred to as being in an "inferior position."

812. ANSWERING AND ACKNOWLEDGING FLAG SIGNALS

- a. A flaghoist is normally answered by addressees repeating the entire hoist at the dip. Heavy ships and unit commanders will always repeat flag for flag. Small ships will normally act in the same manner, but when signalling conditions warrant they may use ANS alone, or below the call of the originator when this is necessary to avoid confusion.
- b. A flag officer or unit commander may answer a flaghoist addressed to him from a ship or unit commander junior to him, by hoisting ANS at the dip, either alone or below the originator's call.
- c. Acknowledgement is effected by hoisting the signal or ANS close up. Signals shall be hoisted close up when understood and by repeating ships when all addressees for whom they are responsible have acknowledged.
- d. When ANS is used to acknowledge a signal, and if a further signal is hoisted after acknowledgement has been given, ANS is to be dipped and rehoisted close up when the subsequent signal is acknowledged.
- e. When an addressee cannot determine the meaning of a hoist or desires to question the meaning, the signal, or ANS shall be kept at the dip, and INT (below the originator's call sign if necessary) shall be hoisted.
- f. Requests may be acknowledged by a senior officer by hoisting CHARLIE (affirmative) or NEGAT (below the call of the ship making the request, if necessary). Such signal constitutes both receipt and answer.

813. **EXECUTING FLAG SIGNALS**

- a. A flag signal is executed when it is hauled down by the originator, unless otherwise indicated.
- b. When a time signal is used it applies only to the group immediately preceding it. When it is required to apply to two or more groups preceding it, BRAVO TANGO is inserted before, and separated by TACK from, the first of the groups to which the time signal is to apply.
- c. If BRAVO TANGO is hoisted separately as the first hoist and left flying during several succeeding hoists, all hoists made in this period will be executed when BRAVO TANGO is hauled down. No time signal is needed with this method of execution.
- d. Certain signals, however, are acted upon as soon as understood. (A note to this effect will be found against the signification of such signals in the Allied Maritime Tactical Signal Book.) Any signal preceded by EMERG is to be acted upon as

soon as understood. Ships having relay responsibilities will not repeat close up until all ships for which they are responsible have answered/repeated close up.

- e. In addition there are certain signals, which are partially executed by dipping the signal. Instructions for these signals are given in the signification of the signal.
- f. All addressees and relaying ships haul down with the originator, except when directed by a subordinate unit commander to delay execution.
- g. When a signal is executed by more than one means, e.g., radio and visual, the first order to execute received will govern the time of execution.

814. **CANCELLING A SIGNAL**

- a. Flaghoist signals are cancelled by the following uses of NEGAT:
 - (1) When only one flag signal is flying, NEGAT hoisted on an adjacent halyard cancels the signal.
 - (2) When two or more flag signals are flying under the same call NEGAT hoisted on an adjacent halyard cancels all signals flying. If only one signal is to be cancelled, it must be repeated preceded by NEGAT.
 - (3) When "all ships" signals and specifically addressed signals are flying at the same time, NEGAT without a call preceding cancels all signals without a call and NEGAT with a call preceding cancels all signals under a similar call. If only one signal of several under the same call is to be cancelled, it must be repeated, preceded by NEGAT under the same call.
- b. The cancelling signal and the signal cancelled are to be hauled down together when all addressees have acknowledged.

815. **CORRECTING A SIGNAL**

- a. Flaghoist signals are corrected as follows:
 - (1) An originating ship cancels the signal in question, then hoists correct signal.
 - (2) A repeating ship hoists the signal meaning "Signal is repeated incorrectly" on an adjacent halyard, then hauls down both signals. The correct signal is then hoisted.

816. **EMERGENCY ALARM SIGNALS**

- a. When emergency alarm signals are hoisted the originator is also to:

- (1) Sound six short blasts on the whistle.
 - (2) Pass the emergency alarm signals to the OTC by the most expeditious means authorized.
- b. The flag signal is to be repeated by all ships. If originated by other than the OTC, the visual call sign of the originator is to be hoisted below FIRST SUB.

817. **EXPEDITING OF FLAGHOIST SIGNALLING**

- a. An originating ship may pass its signal by light if there is doubt that its flags can be clearly seen.
- b. Directional or non-directional light, applying appropriate procedure, may be used. The operating signal ZJL meaning "Hoist the following signal" may be included.
 - (1) If directional procedure is used, the signal will be received for by light and acknowledged in the normal flaghoist manner. The executive signal need not be made by directional light when the flag signal is hauled down.
 - (2) If non-directional procedure is used and no ship will answer, the signal may be repeated as often as necessary with repetitions being separated by IMI and ships will acknowledge by flaghoist. The executive signal will be made by light as the flag signal is hauled down.
- c. If a special flaghoist task organization call sign appears in the hoist, the numeral flag will be spelled out and the numeral pennants transmitted as Morse symbols, e.g., "SIX 4511 for Task Force 45. When a substitute appears as the first flag of a hoist it will be transmitted as FIRST, SECOND, THIRD, or FOURTH, as appropriate.

818. **RELAYING**

- a. General relaying responsibilities are as laid down in Chapter 5 with additional instructions for flaghoist signalling given below.
 - (1) Signals are to be relayed by any ship in a position to help by so doing.
 - (2) Whenever practicable, ships which repeat the OTC's signals are to do so on halyards corresponding to his.
- b. If the OTC hauls down a signal before all ships have acknowledged ships, which have answered the signal hoist it close up, and haul down immediately. Relaying ships are to pass the signal by light to ships for whom they are responsible who have not acknowledged the signal.

- c. Relaying signals from the OTC:
 - (1) Signals are relayed at the dip, and hoisted close up when the ships addressed have acknowledged.
 - (2) The originator is not indicated.
- d. Relaying signals from ships other than the OTC to ships other than the OTC:
 - (1) The originating ship hoists FIRST SUB followed by her call sign, the call sign of the addressee and the text. If the identity of the originator will be evident to all ships within visual communication range, FIRST SUB followed by the call sign of the originator need not be hoisted.
 - (2) The relaying ship hoists FIRST SUB above the call sign of the originator close up, followed by the call sign of the addressee and the text at the dip (hoisted close up when the ship addressed has acknowledged).

EXAMPLE: C58 originates a signal to be relayed to C34 by C33:

<u>C58</u>	<u>C33</u>	<u>C34</u>
<u>Hoists</u>		
First hoist close up	1st C p5 p8	
Second hoist close up	C p3 p4 A D 6	
	<u>Hoists</u>	
	First hoist close up	1st C p5 p8
	Second hoist at the dip	C p3 p4 A

D
6

Hoists

First hoist close up 1st
C
p5
p8

Second hoist at the dip C
p3
p4
A
D
6

Second hoist close up to Acknowledge

Close up to indicate acknowledgement by addressee

Hauls down

Hauls down

Hauls down

- e. Relaying signals to the OTC:

Signals from individual ships to the OTC are relayed as in d. above except that the call sign of the OTC is considered to be understood and is omitted. (See paragraph 806.a (1).)

819. **ENTERING AND LEAVING PORT**

Unless directed otherwise, ships entering or leaving port during daylight will hoist their international signal letters. Visual call signs, address groups, and berth assignments may also be prescribed.

820. **SPEED FLAGS**

- a. In order to facilitate station keeping, the speed at which a ship is proceeding may be indicated by small size numeral flags displayed from the navigation bridge or by regular size numeral flags at the dip from an outboard signal halyard.
- b. Care is to be taken when indicating speeds of ten knots and over that the flag indicating tens is shown above that indicating units.

- c. Speed flags are normally used only when entering or leaving harbor in formation, conducting minesweeping operations or when ordered by the Unit Commander.
- d. Specific details on the use of the foregoing are found in the Allied Maritime Tactical Instructions and Procedures.

821. **SHIFTING BERTHS**

Ships shifting berths within a harbor will conform to local regulations on the display of international signal letters and berth assignments.

CHAPTER 9

MISCELLANEOUS SYSTEMS

SECTION I - SOUND

901. DISTRESS

The continuous sounding of any fog signal apparatus is a signal of distress.

902. WHISTLES, SIRENS, BELLS, ETC

The International Morse Code and special signals are used for this means of communication. When transmitting by whistle, siren, fog horn, or other devices with which the length of sound can be controlled, a short blast represents a dot and a long blast a dash; for transmitting with a device which is struck to create the sound, such as a bell, gong, drum, etc., a single stroke represents a dot and two rapid strokes represent a dash.

903. LIMITATIONS

- a. The use of sound for communication is normally limited to certain specified sound signals. Among the more commonly encountered of these are the signals prescribed for vessels in the "Rules of the Road," air raid alerts, and similar signals. When sound signals are used in special circumstances, as shown below, care must be exercised that they do not conflict with more commonly used signals and thereby confuse ships or stations not familiar with the special signal.
- b. Sound signals other than those included in the "Rules of the Road" are not to be employed in pilotage waters and are only to be used in an emergency when short range radio is prohibited or is not available, or for the sounding of visual call signs on occasions when the Officer in Tactical Command (OTC) may wish to ascertain which ships are within hearing distance.
- c. Sound may only be used by the OTC or by an individual ship having vital information to report to the OTC.
- d. Complete instructions for sound communication between ships in convoy are contained in ATP 2, VOL II or appropriate national or regional defense organization publications.

904. FORM OF MESSAGE

- a. No heading or ending is used in sound signalling. The text only is to be made twice through separated by a pause.

- b. Messages made by any ship other than the OTC are to be followed by the call sign of that ship.

905. **RECEIPTING**

- a. When sound is used by the OTC at least one ship should be directed by him to repeat back or to receipt for the signal.
- b. When sound is used by an individual ship the OTC is always to receipt for the signal with that ship's call sign followed by R. No ship is to relay.
- c. A ship may be ordered to receipt by making that ship's call sign followed by K. It receipts by making DE, its call sign, followed by R.

906. **THE EXECUTIVE SIGNAL**

- a. In those signals, which require it, the executive signal is to consist of a 5 second blast and is to follow immediately after the repetition of the text.
- b. The execute to follow prosign IX is not to be used either in the text or to precede the 5 second blast.
- c. The signal is executed on the termination of the 5 second blast. Ships are not to wait for any ship that may be ordered to receipt or repeat back. When ships are ordered to repeat back they are to include the executive signal if one has been used.

EXAMPLE A: The OTC orders all ships to stop engines:

SPEED SIERRA (pause) SPEED SIERRA (5 second blast) C78 G

All ships stop engines on the termination of the 5 second blast; the cruiser whose visual call sign is C78 makes:

SPEED SIERRA (pause) SPEED SIERRA (5 second blast)

EXAMPLE B: An individual ship reports a man overboard to the OTC:

OSCAR (pause) OSCAR (pause) C2

The OTC makes:

C2 R

EXAMPLE C: The OTC signals SPEED EIGHT and orders C78 to receipt for it:

SPEED EIGHT (pause) SPEED EIGHT (5 second blast) C78 K
 C78 makes:
 DE C78 R

907. **IDENTIFICATION OF SHIPS**

- a. Occasions may arise when the OTC will wish to determine which ships are within hearing. This may be done by the OTC sounding the signal meaning "Sound your visual call sign" made only once.
- b. On hearing this signal ships are to reply by sounding their visual call sign once only without call or ending as follows:
 - (1) If addressed to an individual ship - immediately on hearing the signal.
 - (2) If addressed to more than one ship - the ships will answer in alphabetical sequence of call signs.
 - (3) If no ship sounds within 30 seconds of her proper turn, the next ship is to sound without waiting.

EXAMPLES OF SOUND SIGNALS

SIGNAL	MEANING
One short blast	I am altering my course to STBD.
Two short blasts	I am altering my course to PORT.
Three short blasts	I am operating astern under propulsion.
One prolonged blast at intervals of not more than two minutes	A power driven vessel underway in restricted visibility.
Two prolonged blasts in succession by intervals of not more than two minutes	A power driven vessel underway but stopped and making no way through the water.
One prolonged followed by two short blasts at an interval of not more than two minutes	A vessel not under command. A vessel restricted in her ability to manoeuvre. A vessel constrained by her draught. A sailing vessel. A vessel engaged in fishing. A vessel engaged in towing/pushing another vessel.

SECTION II - INFRA-RED COMMUNICATION908. **GENERAL**

Infra-red communication is a night visual communication method with the added complication that the receiver, unlike the human eye is directional. This complication introduces the necessity for a somewhat rigid system of visual responsibility, and a necessity for the transmitting operator to "control the circuit" as is done in radio.

909. **BASIC FORMS**

- a. Infra-red communication is further divided into two basic forms:
 - (1) Directional, using the standard signal searchlights with filters, or special purpose equipment.
 - (2) Non-directional, using a large infra-red yardarm signalling light, with non-directional procedure.

910. **INTERFERENCE**

To reduce interference, infra-red communications between separate ships are generally directional. A station having traffic for wide distribution will normally use non-directional procedure.

911. **GUARDSHIPS**

The officer prescribing a fleet disposition and officers commanding formations therein will designate the infra-red guardships and promulgate the chain of visual responsibility.

912. **INDICATING TRAFFIC FOR STATIONS**

Before commencing transmission of a long message, the transmitting station should broadcast an operating signal and traffic list indicating the stations for whom he has traffic. In this way outlying stations may secure their equipment if there is no traffic for them.

913. **CALLING PERIODS**

- a. In order to reduce confusion in routine calling and communication, OTCs may prescribe calling periods and instructions for delivery of traffic. The general rule to be followed is that the OTC or guardship, as the case may be, will:

- (1) Call stations and, by means of an operating signal and a traffic list, indicate those for whom he has traffic.
- (2) Deliver traffic, repetitions, etc.
- (3) Receive traffic by predetermined schedule, or when alerted by the term "Nancy" on the voice radio.

914. **POINT OF TRAIN LIGHT (POT)**

The POT is a steady infra-red light used to assist the sender in locating the receiving station and in keeping his light properly trained. It is turned on to indicate that a station is communicating, or is ready to communicate with infra-red. It is turned off at other times.

915. **PROCEDURE**

- a. Directional - At scheduled times or when alerted by voice radio, ships having traffic will turn on POT, locate the ships with whom they wish to communicate, and commence transmitting with directional infra-red searchlights using flashing procedure.
- b. Non-directional - Infra-red procedure is the same as non-directional flashing light procedure. The non-directional light will normally be used for multiple address messages.

916. **NAVIGATIONAL AIDS**

Directional infra-red systems may be used as navigational aids in assault tactics.

917. **USES OF INFRA-RED IN AMPHIBIOUS OPERATIONS**

- a. In amphibious operations, infra-red communication between ship and shore normally will be initiated after request by radiotelephone or flashing light. At the scheduled time ships will turn on their POT to aid the shore stations in locating them.
- b. Signals from the shore may be weak and it will be easy to confuse them with bursts of gunfire. Therefore, accurate locations of shore parties should be obtained from a plot whenever possible.

UNCLASSIFIED

ACP130(A)

9-6
UNCLASSIFIED

Original

CHAPTER 10

PANEL SIGNALLING

SECTION I - INTRODUCTION

1001. GENERAL

- a. Panels are visual signals for sending simple messages to aircraft. There are:
 - (1) Position marking panels.
 - (2) Signalling panels.
- b. Panels should be sufficiently large to be read easily by aircraft and should be so colored as to contrast with the background.

1002. POSITION MARKING

Position marking serves to indicate to aircraft, on request or on the initiative of the ground troop commander, the position on the ground of the most advanced friendly elements or those in contact with the enemy. This is done by means of small individual panels exposed by ground troops.

1003. COMPOSITION OF POSITION MARKING PANELS

- a. Position marking panels measure approximately 0.66m x 0.50m (2 ft by 1 ft 6 ins). Each side should be of a different color, contrasting with the terrain. Panels roll up from each side on rods and can be secured by elastic cords. When no regular panels are available, they can be improvised with newspapers, handkerchiefs, towels, or any other material at hand, which has definite color contrast with the background and surrounding terrain.
- b. Each person holding a position marking panel will, within the limits of personal safety and without attracting the attention of the enemy, display it, when required, by shaking it with the contrasting color side up. Thus, the panel will be more visible and will not be confused with other objects on the ground.

1004. REQUEST FOR POSITION MARKINGS

Request for position marking by aircraft and the signal "Have understood. Cease marking." is sent to troops on the ground by:

- a. Radio, if possible.
- b. Pyrotechnic signals listed in the Communications Instructions of the theater of operations.

- c. Pre-arranged signals with the aircraft (rocking wings laterally, etc.).

1005. **SIGNALLING**

Signalling permits ground personnel to communicate with an aircraft by means of a limited code. Panels laid flat on the ground or other markings are used.

1006. **DESCRIPTION OF SIGNALLING PANELS**

Signalling panels should measure 1.8m x 0.68m (6 ft x 2 ft 3 ins). They should be a light color on one side and a darker contrasting color on the other. When no regular panels are available, the following may be used:

- a. Flexible strips.
- b. Pieces of wood.
- c. Marking on snow, earth, or sand.

1007. **VISIBILITY OF SIGNALLING PANELS**

- a. Signalling panels should be spread on relatively level and preferably grassy ground, unencumbered and free of thick vegetation. The area should be defiladed from enemy observation, but so located that the display can be easily detected from the air. If the panels are two-toned, use the side contrasting more sharply with the background.
- b. In addition, panels should be sufficiently far apart to be read easily. In the following diagrams and examples:
 - (1) a -- 1/2 panel length.
 - (2) b -- 1 panel length.
 - (3) c -- 2 panel lengths.

1008. **SIGNALLING PANEL CODE**

Panels can signal:

- a. Figures (Paragraph 1011).
- b. Letters (Paragraph 1012).
- c. Special signs (Paragraph 1016).

1009. INDICATORS

a. Index Flash

- (1) Index flash is a single panel centred above and at right angles to base panels (Paragraph 1013). It is the last panel put in place and the first to be picked up when the pattern is changed or removed.
- (2) Used without any other indicator it means: "Read as in vocabulary".
- (3) In all other cases it means: "Top of number or word group" and "Ready to read".

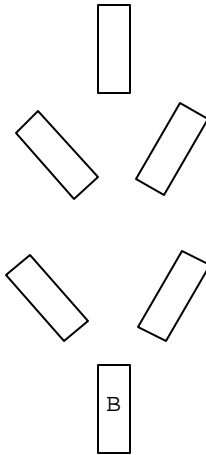

b. Letter Indicator. Shown above index flash it means: "Read as letters". The numbers 1 - 26 represent A - Z.

c. Morse Code Indicator. Shown above index flash it means: "Read as Morse Code".

d. Figure Indicator. Shown above index flash it means: "Read as figures". B marks the base panel.

1010. SENDING NUMBERS

The numerals 0 through 9 are signalled by panels using the code in Figure VII. Numerals stand for:

- a. Phrases and expressions making up a special vocabulary dealt with in Paragraph 1034 - 1043
- b. Names and coordinates specially for completing meaning of phrases and expressions below.
 - (1) Sending of phrases and expressions.
 - (a) The vocabulary used appears in Paragraph 1034 - 1043 and consists of the numerals 0 through 69, each with a special meaning.
 - (b) In this case, the index flash is used alone, without a special indicator and means: "Read as in vocabulary."

EXAMPLE

<u>Meaning</u>	<u>Pattern</u>	<u>Explanation</u>
Vocabulary No. 5. (The meaning is given in Chapter 8, para. 801. Request for small arms ammunition).	<p>a -- 1/2 panel length b -- 1 panel length c -- 2 panel lengths</p>	<p>Index Flash</p> <p>Panel 5</p>

(2) Sending of figures as such (quantities, coordinates).

(a) In such cases, the number indicator is placed 1/2-panel length above where the index flash will be placed. The number indicator is made up of 3 panels forming a Y which means: "Read as figures."

EXAMPLE

<u>Meaning</u>	<u>Pattern</u>	<u>Explanation</u>
The figure 5		<p>Read as figures</p> <p>Index Flash</p> <p>Panel 5</p>

Numbers of two figures are sent in 1 signal.
 Numbers of three figures are sent in 1 signal or 2 signal parts.
 Numbers of four figures are sent in 2 signal parts.

(c) Groups of numerals are separated from each other by a special sign (No 15 in Vocabulary).

a -- 1/2 panel length

b -- 1 panel length

c -- 2 panel lengths

1st EXAMPLE

SENDING OF FIGURE 3205

1st Part

2nd Part

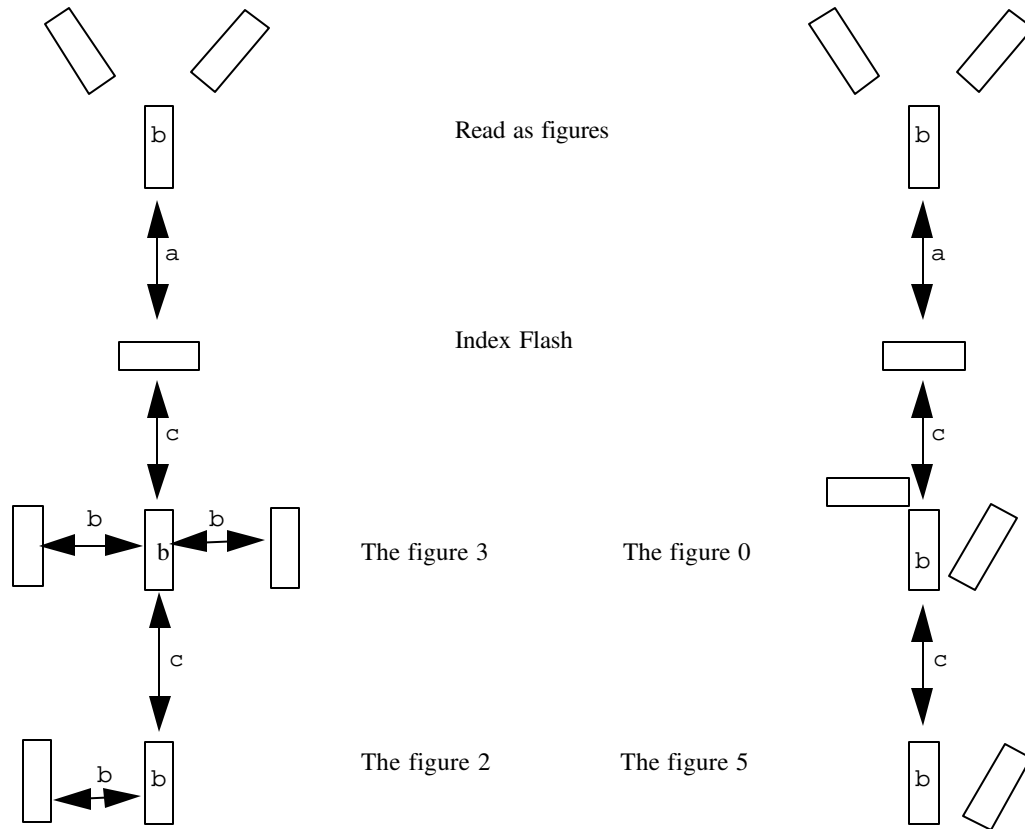

a -- 1/2 panel length

b -- 1 panel length

c -- 2 panel lengths

2nd EXAMPLE

Enemy at 2798 (yards or metres)

1st Signal:

Enemy at (No. 52 in vocabulary).

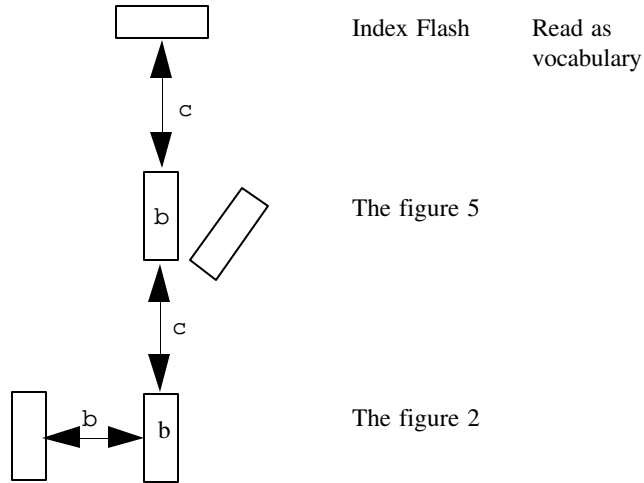

2nd Signal 2798

1st Part

2nd Part

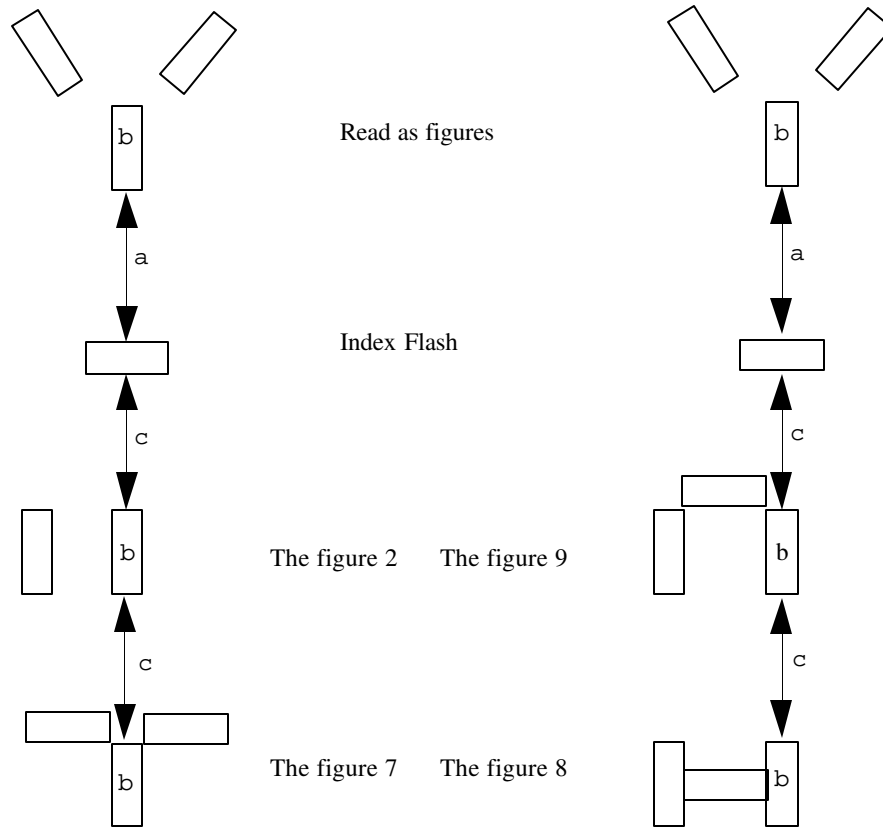

a -- 1/2 panel length
 b -- 1 panel length
 c -- 2 panel lengths

1011. **SENDING LETTERS**

- a. Letter Indicator. The numeral 1, placed 1/2 panel length above the index flash and in line with the basic numerical panels, means "Read as letters."

EXAMPLE A:

Meaning

The letter "D"
("D" is the 4th
letter of the alphabet)

Pattern

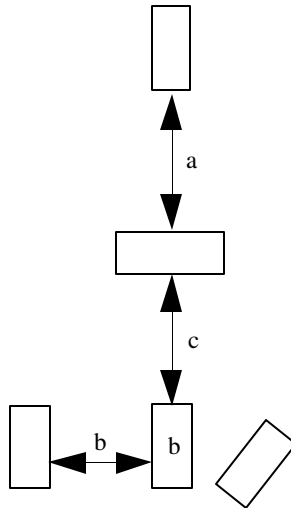

Explanation

Read as letters.

Index Flash

Panel 4

a -- 1/2 panel length
b -- 1 panel length
c -- 2 panel lengths

EXAMPLE B:

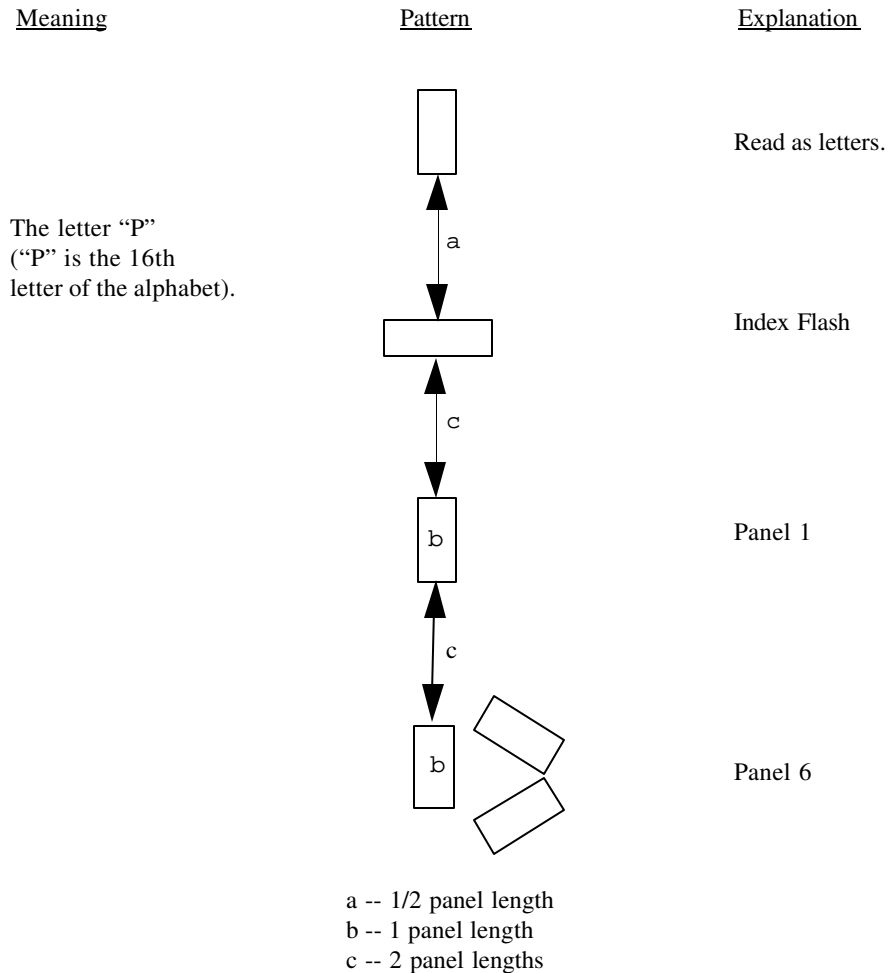

b. Morse Code Indicator

- (1) The letter V, placed 1/2 panel length above the index flash in line with the basic numerical panels, means: "Read as dots and dashes in Morse Code."
- (2) When letters are sent in Morse Code, a dot is represented by a panel perpendicular to the index flash; a dash is represented by a panel parallel to the index flash.

1st EXAMPLE: Sending the letter R

Meaning

Pattern

Explanation

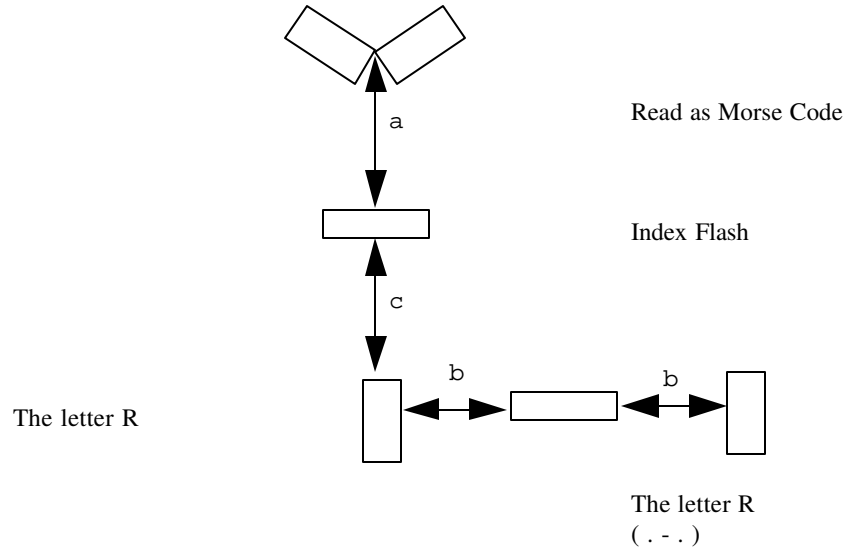

- (3) Combinations of more than two letters are sent in groups of two.
- (4) The separation sign (No 15. in the vocabulary) is used to separate groups of signs or letters sent one after the other.

a -- 1/2 panel length
b -- 1 panel length
c -- 2 panel lengths

2nd EXAMPLE: Request for Estimated Time of Arrival

Ist Signal: Request for (No. 40 in the vocabulary).

Meaning

Pattern

Explanation

No. 40 in the
vocabulary means:
"Request for"

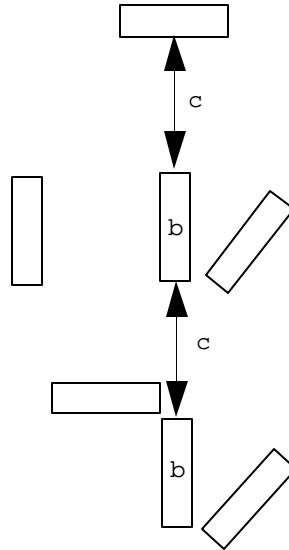

Index Flash only
(read as vocabulary)

The figure 4

The figure 0

a -- 1/2 panel length
b -- 1 panel length
c -- 2 panel lengths

2nd Signal Estimated Time of Arrival (ETA)

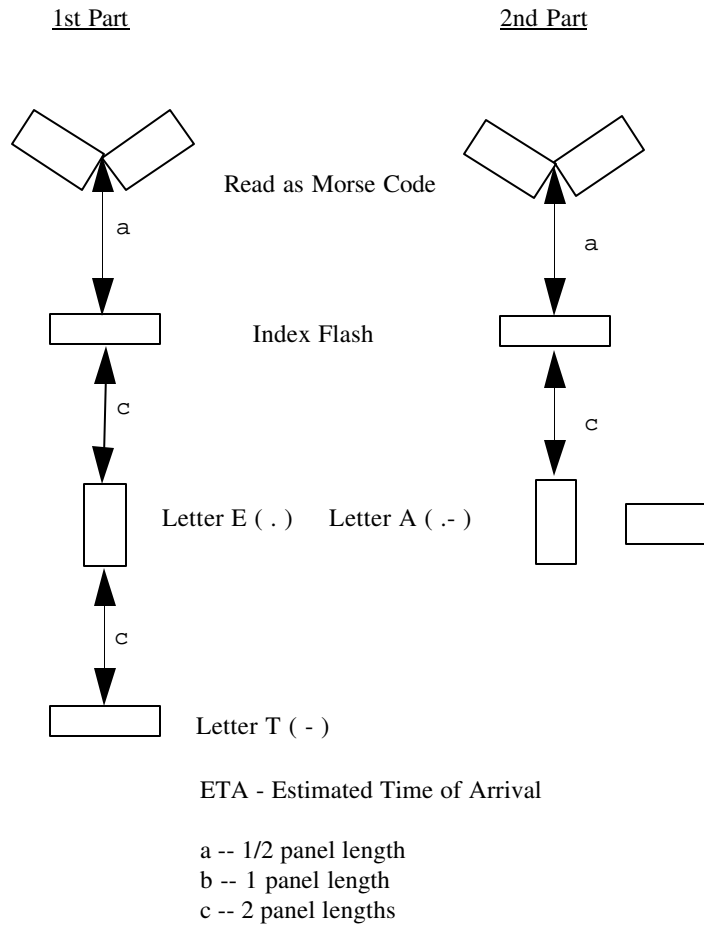

1012. **OPERATING PROCEDURE**

- a. One of the vertical panels in each numeral, and in the indicators "Read as letters" and "Read as numerals", is used as a base panel. They are located centrally with respect to the index flash. The base panels are established first and are kept in place as long as panel signalling is in progress.
- b. One base panel is established to signify that a one-numeral display (pattern) will follow. Two base panels are aligned one above the other to signify that a two-numeral display will follow.
- c. Panel communication may be commenced by an initial display composed of two base panels, one above the other. When the index flash is added, this signifies "I have a message for you". It is usually practicable, however, to proceed with a message without the above display, which is used primarily to attract the attention of an aircraft without pre-arrangement.

- d. When a panel numeral is changed from one to another, the change is made in the most expedient manner by shifting, adding, or removing panels other than the base panel. The index flash is the first panel removed when a display is changed and the last to be laid out when a new display is ready to be read. All panels not in use for a particular display must be removed from view.

1013. SPACING

- a. The spacing shown graphically in this document (marked a, b, c) is the normal spacing as per paragraph 1007. In order to obtain maximum efficiency and speed this spacing should be followed as closely as possible.
- b. Whenever it can be done, it would be advantageous to use panels of double length. However, if the area available is relatively limited as in the case of a road, the overall dimensions of the pattern may be modified without changing the basic pattern. Thus the spacing between base panels may be reduced to one panel length minimum, and to one-half of a panel length between panels making up the numerical numerals 2, 3 and 4; the numeral 7 could be made up of 2 instead of 3 panels.

1014. SIGNALLING AND ACKNOWLEDGING RECEIPT

- a. Messages Received and Understood. Aircraft will indicate that the ground signals have been seen and understood by:
 - (1) Day or Moonlight:
 - (a) Rocking wings laterally.
 - (b) Sending a radio signal.
 - (c) Any prearranged signal.
 - (2) Night:
 - (a) Making green flashes with a signal lamp.
 - (b) Any prearranged signal.
- b. Message Received and Not Understood. Aircraft will indicate that ground signals have been seen but not understood by:
 - (1) Day or Moonlight:
 - (a) Executing a 360 degree turn to the right.
 - (b) Sending a radio signal.

- (c) Any prearranged signal.
- (2) (2)Night:
- (a) Making red flashes with a signal lamp.
 - (b) Any prearranged signal.
- c. New Patterns. Each new pattern should be acknowledged.

SECTION II - SPECIAL SIGNS

1015. GENERAL

These special signs composed of signal panels, should be used without the index flash or indicators of any kind.

1016. DIRECTION OF LANDING

A "T" is used to indicate "Land In this Direction (direction from base to head of "T")".

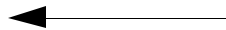
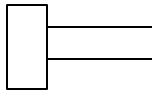

Direction of Landing

1017. DIRECTION INDICATOR

- a. An arrow made up of at least three panels means: "In This Direction".
- b. It can be used by itself or in conjunction with any other pattern to complete its meaning.

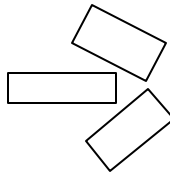

1018. PICK UP MESSAGE HERE

- a. An offer of a message to be picked up by an aircraft shall be made by using the direction indicator in conjunction with two parallel panels. The direction indicator gives the line of approach to the pickup point and should be into the wind. The parallel panels shall be placed upwind from the direction indicator with both panels parallel to the direction

indicator. The message, when ready for pickup, shall be suspended on posts at the ends of each parallel panel remote from the direction indicator.



- b. Message ready for pickup shall be indicated by placing a panel across the line approach between the posts.



1019. **DROP MESSAGE HERE**

Wind direction is indicated by the direction indicator.



1020. **MESSAGE DROP NOT RECOVERED.**

If a message drop is not recovered, the flank panels making the point of the direction indicator in paragraph 1018 shall be removed.

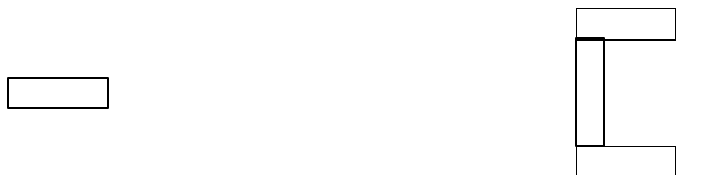

1021. **CROSSED PANELS.**

Panels forming an "X" mean "Unable to Proceed" or "You may not Proceed". It may also be used in conjunction with other panels to imply cancellation.

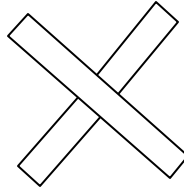

SECTION III - MARKING OF DROPPING ZONES

1022. TYPES OF VISUAL MARKING

- a. Panels - The aerial delivery recognition panels normally used by allied forces, or the best available substitute, shall be used for marking dropping zones during daylight operations. Panels should have contrasting characteristics with the surrounding terrain. The size of the letters used should be 27m x 27m (9Ø ft x 9Ø ft) providing adequate space and marking equipment is available. The absolute minimum acceptable will be 13.5m x 13.5m (45 ft x 45 ft). These markings should normally be visible under Visual Meteorological Conditions (VMC) at a distance of not less than three nautical miles (5.5 kilometers) from a height of 1,500 ft above ground level.
- b. Lighting - Standard lighting equipment normally used by allied forces, or the best available substitutes shall be used, together with, or in the place of, panels during the hours of darkness or poor visibility. The systems used should be capable of being read from a vertical height of 1,500 ft above ground level. Tactical situations may sometimes dictate that lighting be visible only from above in which case shielding devices must be provided to direct the light accordingly. Such devices should beam the lighting towards the flight path or sound of the approaching aircraft.
- c. Smoke, Flares and other Devices - These may be used to give an indication of wind direction and the location of the Drop Zone if this is considered necessary. They should be placed downwind of the Drop Zone/Landing Zone symbols in order to preclude those symbols from being obscured. Colors and detailed techniques for the use of these items will be given in operational plans.

1023. CODE IDENTIFIERS

The code identifier is used to identify a particular dropping zone. It shall consist of block letters formed from panels or lighting or a combination of methods to meet the situation. Only the specific letters A, C, J, R, and S will be used as identifiers to avoid conflict with other panel signals. Type of marking by day or by night, details of the code identifiers and any marking substitutes will be defined in operational plans. The identification letters shall be displayed until the drop is completed.

1024. MARKING OF DROPPING ZONES

- a. A detailed marking of dropping zones is given in Figures I and II.

- b. The Impact Point - This is the point where the first parachute or equipment should land. The impact point marker is to consist of a code identifier, as detailed in paragraph 1023.
- c. The Dropping Zone Indicator - Whenever necessary and if facilities are available, the dropping zones may be marked with the symbol "P" located approximately 180m (600 ft) to the left of, and in line with, the code identifier.
- d. No Drop-and Dropping Temporarily Postponed - Temporary postponement is indicated by two vertical bars "II" under the code identifier. No drop is indicated by an "X" under the code identifier.
- e. Boundary Limit Marker - If required these may be used to indicate the usable limit of the drop zone.

1025. EMERGENCY MARKING

Because of unusual circumstances or camouflage requirements, it may not be possible to lay out the ground markings in accordance with Figures I and II. In this case, the dropping zone shall be marked by any alternative means such as smoke and fires.

1026. UNMARKED DROPPING ZONES

Where the dropping zone cannot be marked by any method, dropping is still possible if the pilot is provided with a large scale map or air photograph showing the dropping zone axis and direction of drop.

SECTION IV - MARKING OF LANDING SITES AND STRIPS

1027. GENERAL

- a. A landing zone is a zone containing a number of landing sites and/or landing strips. Landing sites and landing strips are marked but landing zones are not marked.
- b. In order not to disclose positions to the enemy, markings should be kept to a minimum and only displayed when actually required.

1028. TYPES OF VISUAL MARKING

- a. Panels - Recognition panels normally used by allied forces or the best available substitute shall be used for marking landing areas during daylight operations. Panels should have a color contrast with the surrounding terrain.
- b. Lighting - Standard lighting equipment normally used by allied forces, or improvised lighting shall be used together with, or in the place of, panels during the hours of darkness or poor visibility.

1029. **MARKING OF LANDING STRIPS**

- a. The detailed marking of landing strips is given in Figures III and IV.
- b. Dimensions - The length, width and panel marking of a strip will vary according to the type of aircraft utilizing it. Figure III reflects adequate marking for light aircraft; Figure V details the markings involved in airborne operations involving multiple aircraft landings in a high density pattern.
- c. Landing Direction - The letter "T" is used to indicate "land-in this direction" (direction from base to head of T) and should be sited to the left of the intended landing path at the approach end of the strip.
- d. Wind Direction - The wind direction may not be the same as the direction of landing. If the tactical situation allows, it should be indicated by a wind sock or other visual means.
- e. Additional Markings - Additional markers may be spaced along the sides and ends of the strip linking the corner markers. Bad ground must be marked and markings must be visible from the air and from the ground.
- f. No landing - If the strip is not to be used, a large cross 13.5m x 13.5m (45 ft x 45 ft) will be displayed in the centre of the strip.

1030. **MARKING OF HELICOPTER LANDING SITES**

- a. Display of markers - There is a danger of insecure markers being dislodged by the downwash from the helicopter, and causing damage by being sucked up into the rotors. Panels or lights should therefore be firmly secured, or removed before the helicopter hovers above them.
- b. Day Marking
 - (1) The detailed marking of helicopter landing sites by day is given in Figure V.
 - (2) Identification - The letter "H" indicates a helicopter landing site. Individual landing points within a landing site may be indicated by a ground marshaller, panels or any form of obvious marker such as a small flag. Where it is necessary to differentiate between neighboring landing zones, sites or points, details will be given in operational plans.
 - (3) Wind Direction - The letter "H" or panels used to indicate the landing site should be displayed at the up-wind edge of the landing area. Smoke may be used to indicate the wind direction, or as an additional means of identifying the landing site, but should be placed at the downwind side to avoid obscuring the touchdown point.

- (4) Specific Landing Points - If specific landing points within the helicopter landing sites are not to be used, a large cross, 13.5m x 13.5m (45 ft x 45 ft), will be displayed in the center of the site.
- c. Night Markings
- (1) For night landings, individual landing points within landing sites are marked. Two methods are shown in Figure VI.
 - (2) Primary Method - Five lights are laid out on the ground, or hand held by troops lying on the ground, at 9m (30 ft) intervals to form the letter "T," 18m x 18m (60 ft x 60 ft). The horizontal bar of the "T" is placed upwind, so indicating wind direction to the pilot.
 - (3) Emergency Method - Tow vehicles are placed 35m (115ft) apart and 35m (115ft) downwind of the center of the landing point with their headlight beams intersecting at the center of the landing point. The helicopter will approach into wind, pass between the vehicles, and land in the pool of light.
 - (4) Additional Lighting - Such as glide path indicators may be used, but as these may not be standardized care should be exercised when using landing sites of other nations.

SECTION V - IDENTIFICATION

1031. GENERAL

This paragraph should be read in conjunction with the relevant parts of ACP 150 - Recognition and Identification Instructions, Air Land and Sea Forces. It is limited to the method of identification used with panel signals.

1032. IDENTIFICATION OF DROPPING ZONES

Dropping zones will be identified as prescribed in paragraphs 1024 to 1028, by a letter placed as shown in Figures I and II.

1033. IDENTIFICATION OF GROUND FORCES

- a. Panel Sets of one red and one yellow fluorescent panel equipped with tie cards shall be used. Each panel shall be approximately 1.8m x 0.68m (6 ft x 2 ft 3 ins).
- b. Panel Sets should be carried by each platoon or forward element and by each vehicle.

- c. The sign and arrangement of panel(s) to be displayed for identification shall be prescribed in operational instructions. Commanders must also ensure that those instructions define the conditions under which panels shall be displayed for identification.
- d. Because of the ease with which this method of identification may be compromised, it should be supplemented by any of the other means described in ACP 150.

SECTION VI - VOCABULARY

1034. **MAIN COMBAT MESSAGES**

- Ø You may land here.
- 1 We are attacking.
- 2 Do not parachute or land for the time being.
- 3 Request food supplies.
- 4 Request water.
- 5 Request ammunition for small arms.
- 6 Request medical supplies.
- 7 Request POL.
- 8 We have attained our objective.
- 9

1035. **INTELLIGENCE ON FRIENDLY ACTION**

- ØØ I am staying here.
- Ø1 Our attack has failed.
- Ø2 We are in position and ready to attack.
- Ø3 We are taking up defensive position here.
- Ø4 We have been stopped by anti-tank obstacles in the direction indicated.
- Ø5 Our troops are at . . . (followed by coordinates).
- Ø6 We are surrounded.
- Ø7 We are pulling back.
- Ø8 We are going to move (Direction or coordinates of new location can be shown.)
- Ø9 We are changing Command Post. (May be followed by coordinates of new location.)

1036. **PROCEDURAL SIGNALS**

- 1Ø Wait. (Figures may follow showing number of minutes.)
- 11 I have a message for you.
- 12 Received your message.
- 13 Repeat your message.
- 14 Cancel last message pattern.
- 15 Separating signs.
- 16 Nothing more to say.

- 17 No or negative.
- 18 Yes or affirmative.
- 19 Come back tomorrow.

1037. **LIAISON**

- 20 I do not receive your signals.
- 21 Your signals are weak.
- 22 Radio not ready or unserviceable.
- 23 Your message not understood.
- 24 Are you receiving my signals?
- 25 I have no other means of communication.
- 26 Use visual signals.
- 27 Message understood.
- 28 I am asking for contact on following frequency.
- 29

1038. **ARTILLERY OBSERVATION**

- 30 Not ready to fire.
- 31 Ready to fire on target.
- 32 Cannot fire on target.
- 33 Check reference on map.
- 34 I do not need you anymore.
- 35

1039. **GENERAL**

- 36 I know my position.
- 37 I am moving towards the site -- in the direction indicated.
- 38 I am going to a water point or a supply depot indicated by you and will remain there.
- 39 Everything all right -- no help requested.

1040. **SPECIAL REQUESTS**

- 40 Request (followed by letters or Figures). Figures may show number of packages to be dropped.
- 41 Request reinforcement.
- 42 Request mortar ammunition.
- 43 Request anti-tank ammunition.
- 44 Request artillery ammunition.
- 45 Request additional instructions.
- 46 Request my position.
- 47 Request shoes and clothing.

- 48 Request medical assistance.
- 49

1041. **INTELLIGENCE ON ENEMY ACTION**

- 50 The enemy is attacking
- 51 The enemy in possession of landing field.
- *52 The enemy at:.... (followed by coordinates).
- 53 Enemy attack has broken through.
- 54 Enemy attack has failed.
- 55 Enemy preparing attack.
- 56 Have been informed enemy aircraft approaching.
- *57 Enemy concentration in direction shown.
- *58 Enemy automatic weapons in direction shown.
- *59 Enemy artillery in direction shown.

1042. **INSTRUCTIONS FOR AIRCRAFT**

- 60 Carry out reconnaissance in direction shown.
- 61 Following is magnetic direction. Letters or Figures show reading.
- *62 Ask for air support in direction shown.
- *63 Interesting target in direction shown.
- 64 If you can see our elements, fly in circles and in the direction shown.
- 65 Give my position to the Command Post.
- 66 Indicate closest food supplies by circling and flying in the correct direction.
- 67 Indicate closest water point by flying in circles and in the correct direction.
- 68 Do not attack.
- 69

1043. **INSTRUCTIONS TO HELICOPTERS.**

- 70 This is an ammunition pick-up point.
- 71 This is a refueling point.
- 72 This in an emergency medical evacuation point.
- * Numbers 52, 57, 58, 59, 62, and 63 may be accompanied by a Figure showing hundreds of meters or yards depending on user.



SECTION VII - EMERGENCY SIGNALS

1044. **GROUND/AIR VISUAL SIGNALS FOR USE IN EMERGENCY BY SURVIVORS**

The following code is used in case of emergency by personnel having crashed or parachuted in a distant area and requiring medical aid, food or information, such as direction to take in order to find help. No indicator is used for this code which is used only in emergencies.



Message	Code
Require Assistance	V
Require Medical Assistance	X
No or Negative	N
Yes or Affirmative	Y
Proceeding in this Direction	Arrow at 12 o'clock
If in doubt, Use International Symbol	SOS

1045. **GROUND/AIR VISUAL SIGNALS FOR USE IN EMERGENCY BY SEARCH PARTIES**

Operation Completed	LLL
We have found all personnel	<u>LL</u>
We have found only some personnel	++
We are not able to continue. Returning to base	XX
Have divided into two groups, each proceeding in direction indicated	
Information received that aircraft is in this direction	
Nothing found. Will continue to search	NN

1046. **GROUND/AIR VISUAL SIGNALS FOR EMERGENCY-USE IN MILITARY OPERATIONS**

The following signals will be used in military operations in conjunction with those in paragraphs 1044 and 1045 to convey information to an aircraft in an emergency. Commanders may prescribe the use of appropriate identification signals for use in conjunction with the code in their own theater of operations if necessary.

Meaning	Code
Casualty requiring Immediate evacuation	
Require radio with batteries	
Require radio batteries	°
Ground Party in action with enemy	E
Enemy attacking or preparing to attack (from direction of apex of A)	E A
Target of opportunity in direction shown	E 
Request air support in the direction of arrow (each band 200 yds)	E 
Enemy concentrated in direction indicated. Not in Contact	E 
Enemy withdrawn	E X
Cancel air strike	X A
Cancel supply drop	XXX
Nothing more to communicate	XN
Meaning	Code
I have a message for you	I U

Message received U

Are you receiving my signals UI

Enemy in possession of landing ground  E

Temporary landing ground 

Do not land here 

Land in this direction (from base to head of 'T') T

Emergency drop here TZ

Helicopters touch down H

(not to scale)

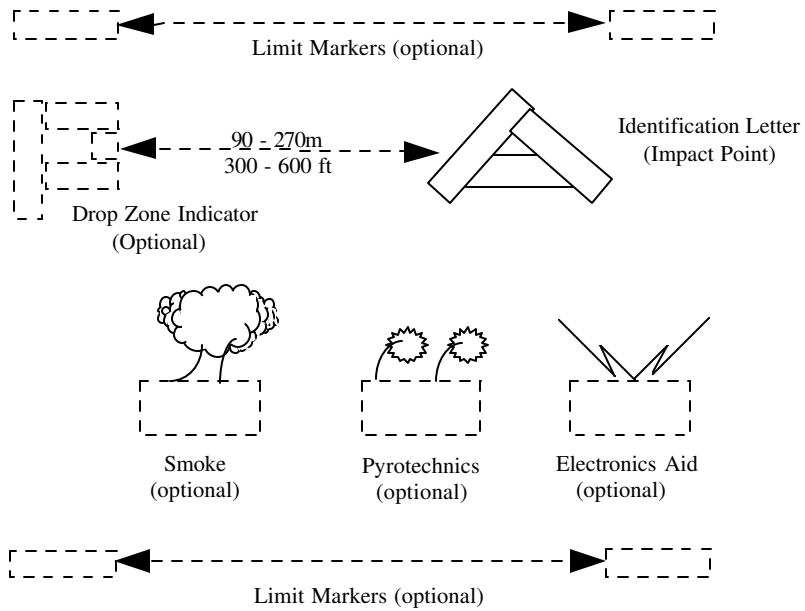

Signals Forbidding Dropping or Parachuting

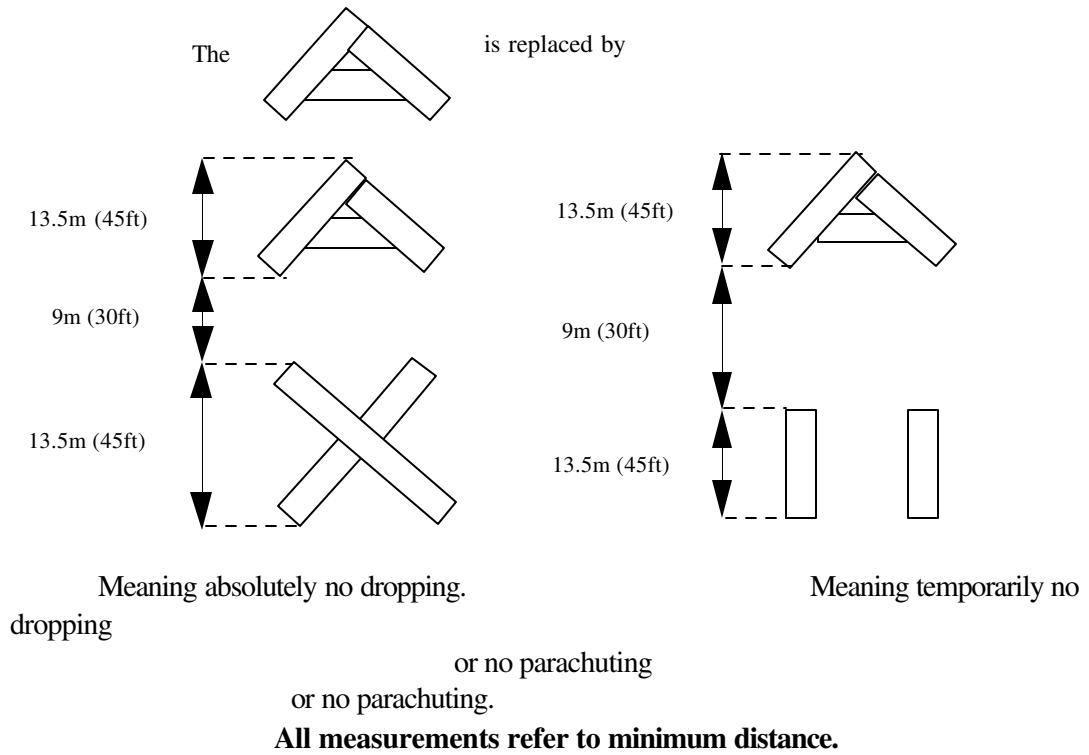
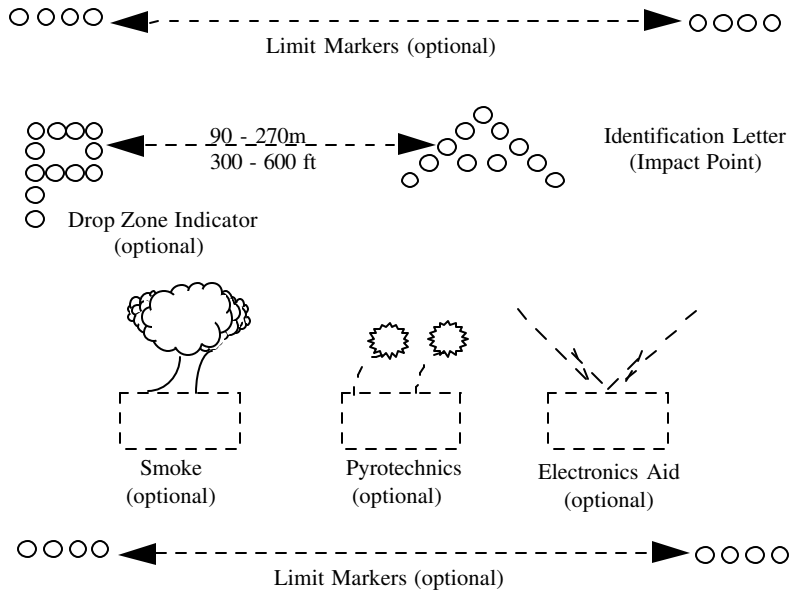
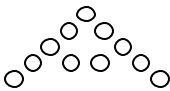

Figure 10-1 Visual Markings Of Dz By Day

(not to scale)



SIGNALS FORBIDDING DROPPING OR PARACHUTING

The  is replaced by

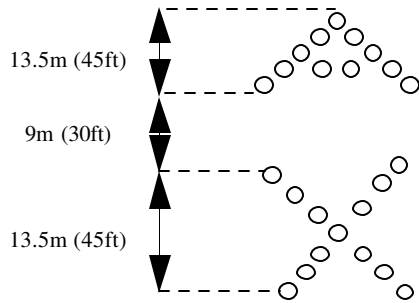

Meaning absolutely no dropping
dropping
or no parachuting
no parachuting.

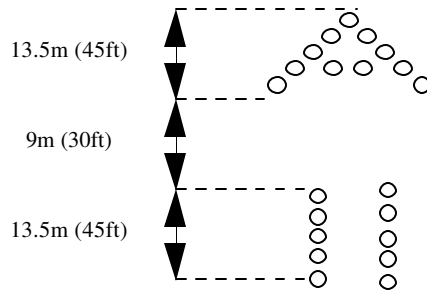

Meaning temporarily no
dropping
or

Figure10-2 Visual Markings Of Dz By Night

(Not to Scale)

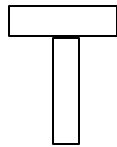
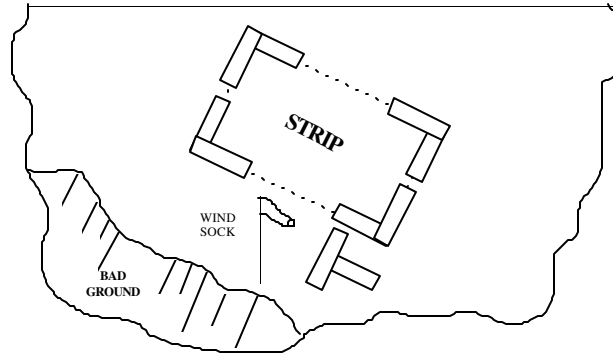

Land in this Direction
(from base to head of T)

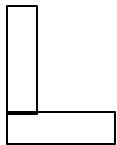

Corner Markers

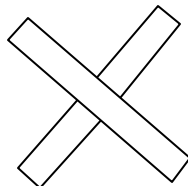

Do not Land

Figure 10-3 Visual Marking Of Landing Strips By Day

(For multiple aircraft landings to
high density pattern)

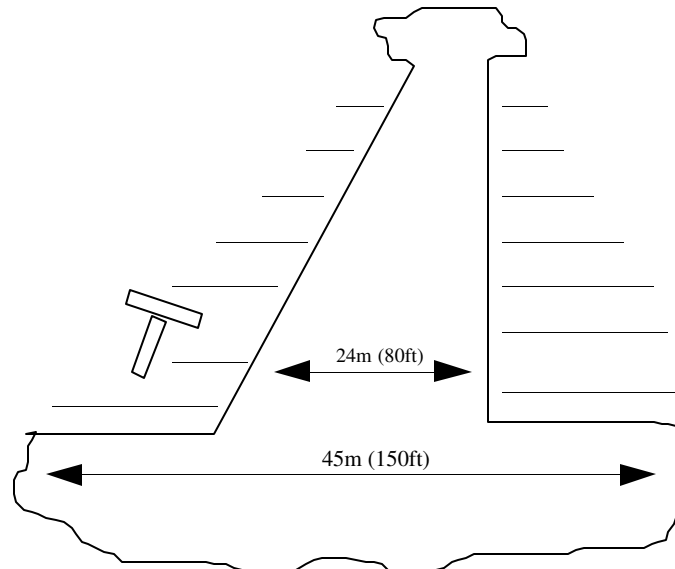

Notes:

1. Length of strip to be determined by requirements of operating aircraft and should provide for overrun.
2. Except for identifying letters, all marker panels will be erected at a 45 degree angle from the horizontal to enable the pilot to observe readily the markings when the aircraft is on final approach. At the discretion of the mission commander, the panel markers will be erected to provide for landing in opposite direction. This is accomplished by erecting the panels in the form of a tent. To do this, stake a second panel on the opposite side of the first panel. To allow for prop blast of the aircraft cut a series of flaps in the panels to allow for air flow through the panels.

Figure 10-4 Visual Marking Of Landing Strips By Day

(Not to Scale)

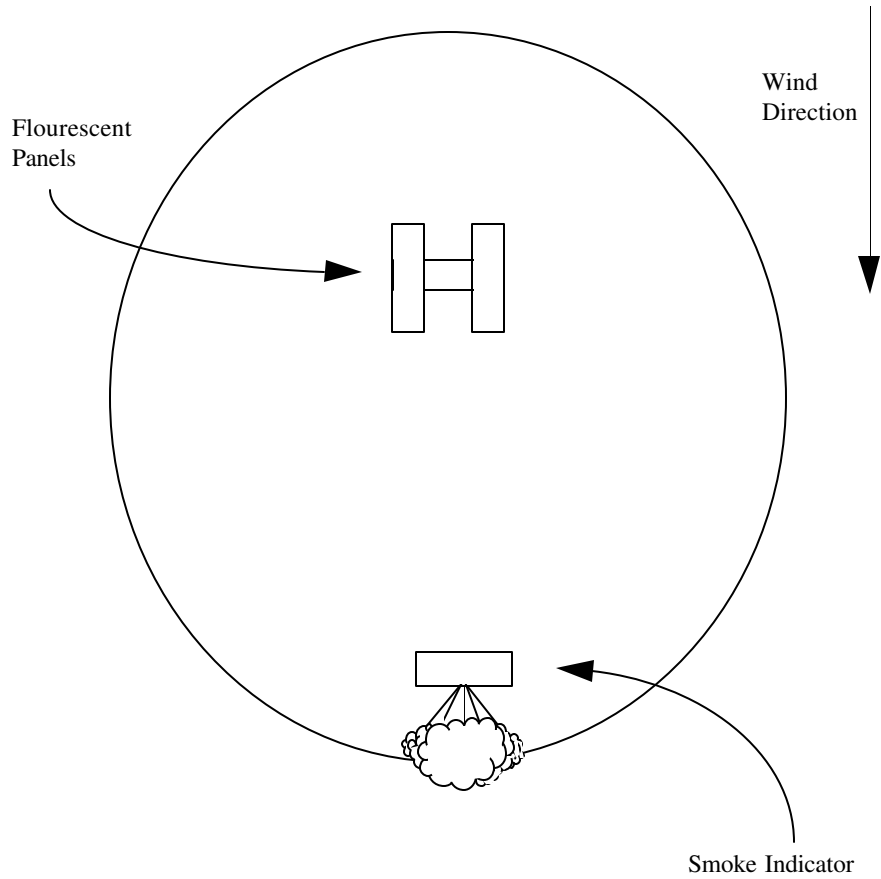

Caution: Place the smoke indicator on the downwind side so not to obscure the intended landing site.

Figure 10-5 Visual Marking Of Helicopter Landing Site By Day

(Not to Scale)

Method 1. Night Landing Point: Primary Marking Method

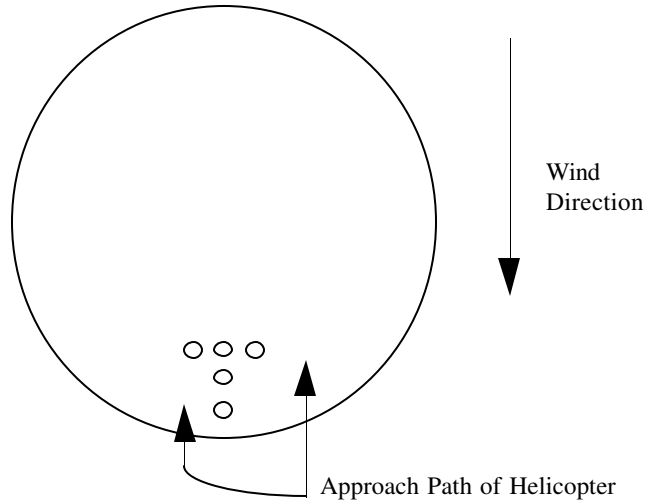

Method 2. Night Landing Point; Emergency Marking Method

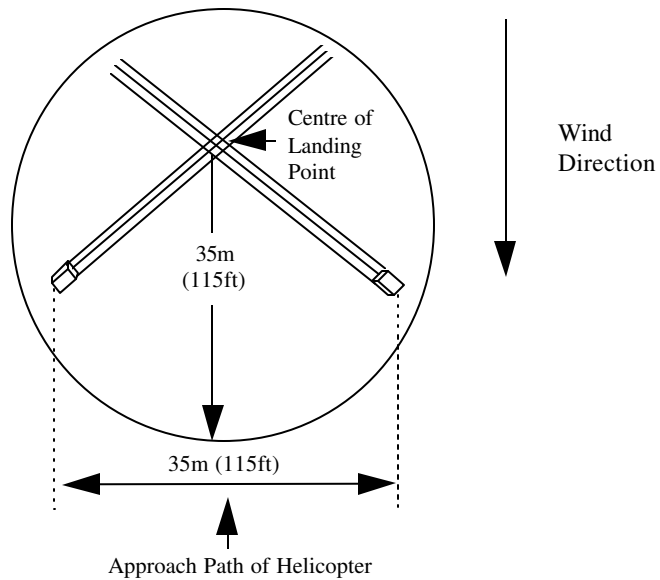

Figure 10-6 Visual Marking Of Helicopter Landing Site By Night

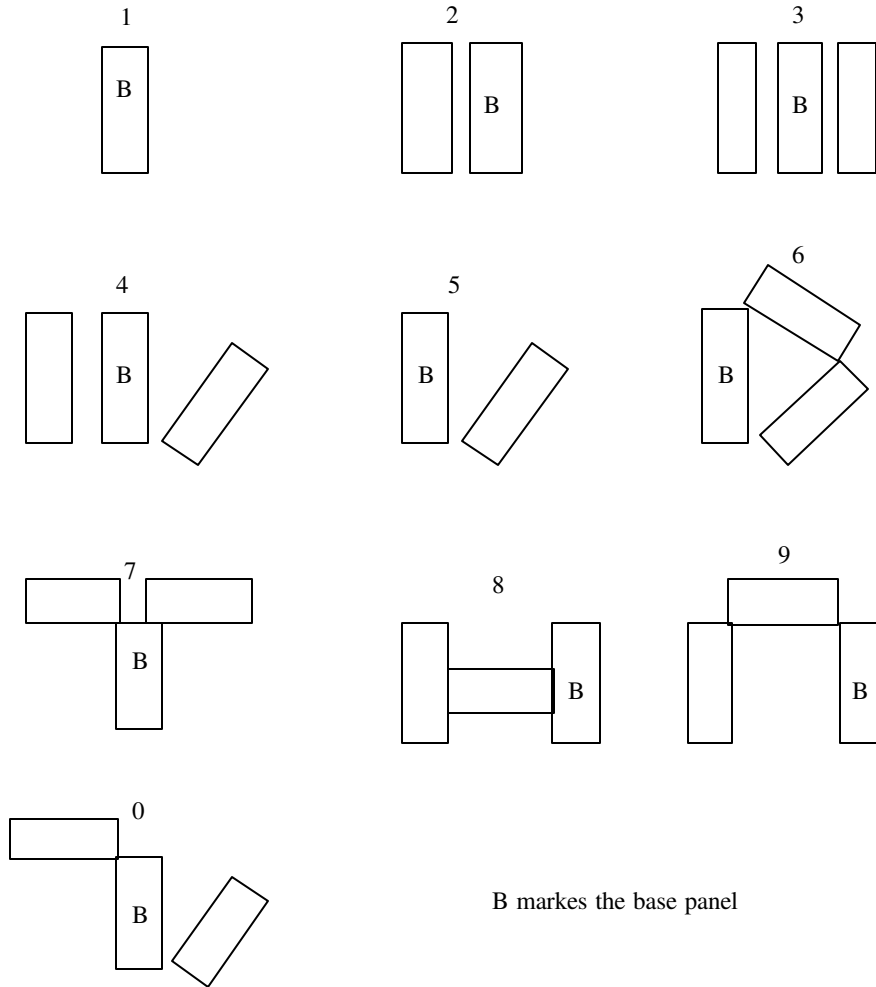

Figure 10-7 Panel Code - Figures

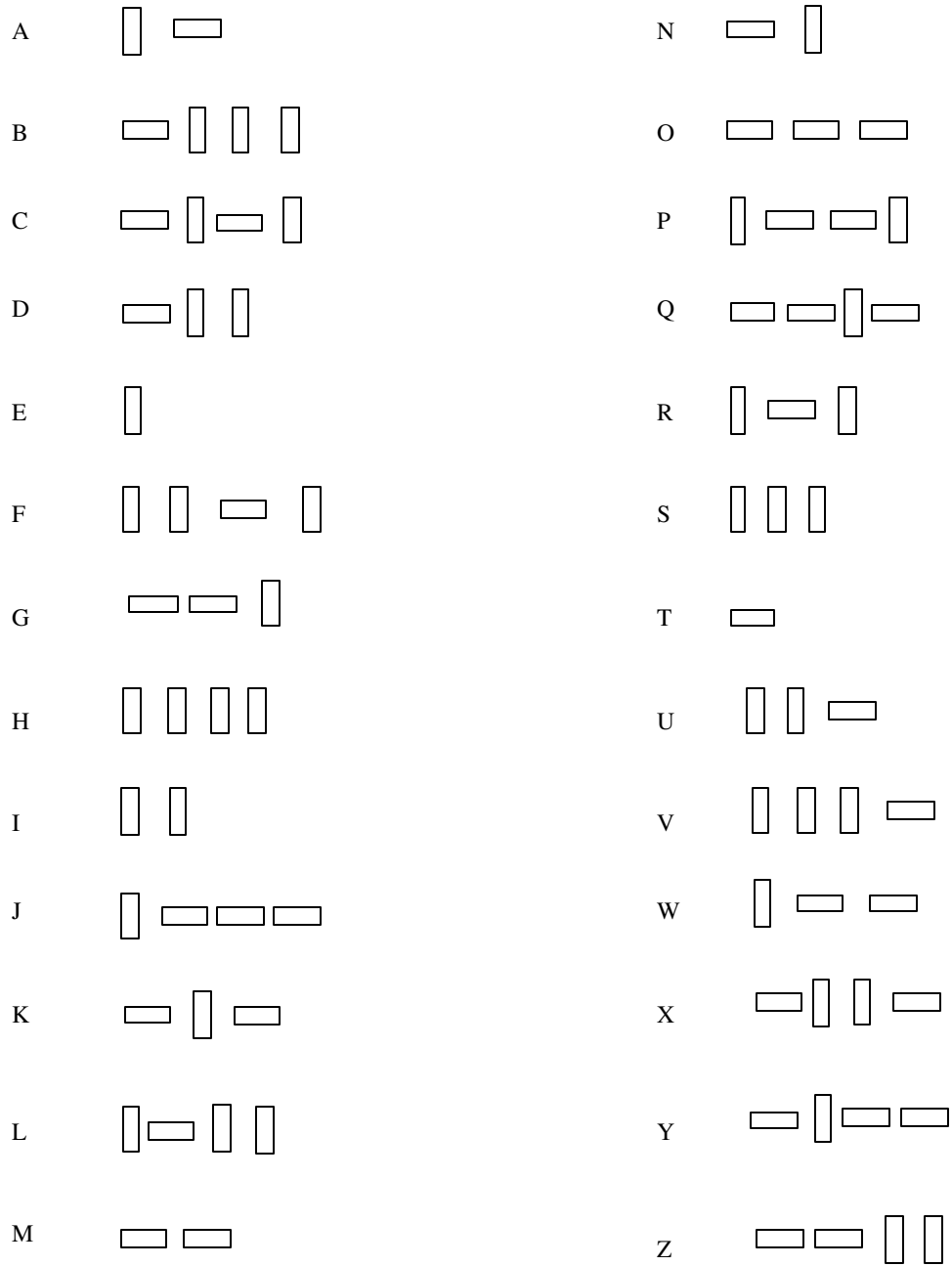

Figure 10-8 Panel Code - Letters

CHAPTER 11

PYROTECHNICS

SECTION I - INTRODUCTION

1101. **PURPOSE AND SCOPE**

- a. This chapter describes the basic pyrotechnic signals agreed for use by nations, but does not include recognition signals.
- b. Theatre, Operational and Tactical Commanders may:
 - (1) Authorize alternative or additional meanings provided there is no confusion to forces not taking part in the operation or exercise.
 - (2) Prohibit the use of certain signals in order to prevent dangerous situations developing. For example, at sea a single red light could be either:
 - (a) A Convoy Commodore's order for an Emergency Turn to Port: or
 - (b) A submarine indicating Emergency Surfacing, to their exercise participants. In exercises where both convoys and submarines were present, the Officer in Tactical Command (OTC) should restrict the use of this signal to submarines only.

1102. **DEFINITIONS**

- a. Pyrotechnic Light includes all pyrotechnics which provide a temporary source of light,
- b. Pyrotechnic Smoke includes all pyrotechnics, which provide a source of smoke.
- c. Pyrotechnic Signal is the all inclusive term embracing both light and smoke signals.

NOTE: In certain circumstances an alternate means, such as an electrical source (e.g., a signalling lamp), may be used in lieu of the pyrotechnic light. In these cases, the signals listed in Figure I and IV of this chapter shall apply.

1103. **LIMITATIONS**

Pyrotechnics, because of their nature are limited in their use. The following limitations are listed as a guide when selecting various Pyrotechnic Signals for use.

- a. Simplicity, as opposed to complicated combinations, is essential. Signals consisting of a succession of pyrotechnics or a combination of color should, if possible, be avoided, as there is always the danger that an observer may not have seen the whole of the signal and may consequently misinterpret it.
- b. It has been found by experiment that the standard colors, red, white (or yellow) and green are the only colors which give satisfaction under the varying conditions of visibility. There are also limitations on the satisfactory manufacture of colors other than the standard red, white (or yellow) and green.
- c. Pyrotechnic signals are easily copied by the enemy. Little reliance can therefore be placed on them, unless the source of origin can be definitely identified.
- d. The enemy are likely to use pyrotechnic signals either for their own purposes or to confuse their opponents.
- e. Under certain atmospheric conditions, white signals may appear as yellow; these two colors are therefore synonymous.
- f. In certain conditions of humidity a white pyrotechnic is liable to be mistaken for green.
- g. Tracer is particularly liable to be confused with red pyrotechnics.
- h. At a distance it is difficult to identify the exact position from which a pyrotechnic signal was fired; consequently, a single pyrotechnic fired from each of two widely separated positions may appear to an observer as two pyrotechnics fired simultaneously or in succession. Also, since many of the signals are high angle and can be seen for great distances, tactical meanings assigned to particular signals must be coordinated at the highest level of command operating in a given area.
- i. The originator of a pyrotechnic signal has no method of knowing whether the signal has been observed by the authority for whom it is intended, unless the action taken by this authority indicates receipt (e.g., ceasing fire). Therefore the signal should be confirmed by other means such as radiotelegraph, radiotelephone or telephone as quickly as possible.
- j. Once a pyrotechnic signal has been fired it can only be cancelled by using a different pyrotechnic device or by some other method of communication such as radiotelegraph, radiotelephone, or telephone.
- k. The range of visibility is largely dependent on weather conditions and is therefore, variable and unreliable.
- l. Pyrotechnic signals should not be expected from modern high speed jet aircraft.

m. An identification table for the very flare is at Figure VI

1104. NIGHT OR DAY USAGE

The signals listed in Figures I through V may be used either by night or-day unless otherwise specified (e.g., Figure II, line 2).

Line	Signal	Where Used	Meaning	Remarks
From Aircraft				
1	One RED light or a succession of RED lights.	At Sea, over Sea or over land.	Aircraft in distress (see line 3 for seaplane in distress on the water).	See line 2 for additional meaning international.
2	One RED light or a succession of RED lights.	In vicinity of a carrier or airfield	Immediate landing is required. No radio available.	
3	A succession of RED lights.	From a seaplane on the water.	Seaplane on the water in distress and requires assistance.	See line 5.
From Ship				
4	A succession of RED lights.	By a ship operating aircraft of helicopters.	Do not land even if previously authorization has been given.	
5	A succession of RED lights.	At sea.	Ship in distress and requires assistance.	See line 3.
From Submarine				
6	One RED light repeated as often as possible.	At sea during submarine exercises.	Keep clear. I am carrying out emergency surfacing procedures.	<u>Warning</u> - Submarine may surface simultaneously with RED light. Ships are to act in accordance with current instructions. See Figure III, line 8.
Miscellaneous				
7	One RED light.	By convoys.	Emergency turn together 45° to PORT.	
8	One RED light.	From the ground at an airfield.	Do not land for the time being (not withstanding any previous permission).	International.
9	One RED light.	From the ground an airfield.	For an aircraft on the ground 'Stop' or hold present position.	International.
1Ø	One RED light.	From the ground in armament	Emergency cease train ing.	

Line	Signal	Where Used	Meaning	Remarks
		training areas only.		
11	One RED light or a succession of RED lights.	From any crew in distress.	Am in distress.	
12	Succession of RED lights.	From the ground at an airfield.	1. Aircraft on ground, taxi clear of landing area (runway) in use. 2. Aircraft in the air, airport unsafe, do not land.	International.

Figure 11-1 - Red

Line	Signal	Where Used	Meaning	Remarks
From Aircraft				
1	One GREEN Light.	By aircraft in vicinity of airfield.	By night- request permission to land. By day - request permission to land in any direction other than that authorized.	To be used only when the aircraft is unable to use radiotelephones, radiotelegraph , lamp or projector.
2	Two GREEN lights fired simultaneously.	Fired by an aircraft over land when cooperating with Land Forces in Battle Areas or Military Practice.	Aircraft is about to drop a message.	By day only. When it is intended to use this signal in practice areas, all authorities concerned must be warned 24 hours before a particular practice is to be carried out.
3	One GREEN light every 5 minutes.	From an aircraft on search and rescue operations.	Call for distressed crew to fire RED pyrotechnic.	On sighting signal from distressed crew interval between GREEN signals to be halved. See line 6.
4.	One GREEN light.	From aircraft in vicinity of a carrier.	Aircraft wishes to land but has no immediate need.	Not to be used unless aircraft unable to use other means of communications.
From Ship				
5	One GREEN light.	At sea.	Ship has fired or simulated firing exercise torpedo.	See line 9.

UNCLASSIFIED

ACP130(A)

Line	Signal	Where Used	Meaning	Remarks
6	One GREEN light every 5 minutes.	From vessels on search and rescue operations.	Call for distressed crew to fire RED pyrotechnic.	On sighting signal from distressed crew interval between GREEN signals is to be halved, line 3.
7	A succession of GREEN lights.	From a ship operating aircraft.	Return for landing.	
8.	One GREEN light.	From a ship operating aircraft.	Cleared to land.	
From Submarine				
9	One GREEN light.	At sea.	Submarine has fired or simulated firing exercise torpedo.	See line 5.
Miscellaneous				
1Ø	One GREEN light.	From an airfield.	Cleared to Land.	
11	One GREEN light.	By convoys.	Emergency Turn together 45° to STARBOARD.	
12	One GREEN light.	In explosive demolition areas on land.	Stand by.	Only to be used: a. By day only. b. When the nature of the land, or distance, renders other forms of signalling (i.e. whistle or flag) impracticable. c. In conditions of good visibility. By the appropriate notice specified in local regulations. Warning of intended use is to be given to local police, coastguard, hospital and civil aviation authorities. Not to be used over the sea or fired out to sea.
13	One GREEN light.	From an airfield.	For aircraft on the ground. Aircraft at entrance to runway "you may enter the	International.

Line	Signal	Where Used	Meaning strip and take off’.	Remarks
14.	A succession of GREEN lights.	From an airfield.	1. Return for landing. 2. Aircraft ready to taxi, “you may taxi but keep clear of runway in use”.	International.

Figure 11-2 – Green

Line	Signal	Where Used	Meaning	Remarks
From Aircraft				
1	One WHITE light.	Air-to-air, ship - air-ground firing areas.	Cease-fire. Pay attention to signal lamp or aircraft manoeuver signals.	
2	One WHITE light.	From aircraft at sea.	Submarine below.	Merchant ships keep clear.
3	Two WHITE lights in succession.	Over sea.	Aircraft dropping sonobuoys.	
4	One WHITE light.	Air combat area over sea.	Cease-fire. Watch signals from ships and aircraft.	
5	Succession of WHITE lights.	From aircraft over sea or land.	Aircraft in difficulties, which compel it to land, immediate assistance not required.	International.
From Ship				
6	One WHITE light	At sea	Man Overboard	Peacetime
7	Two or more WHITE lights in quick succession.	At sea or in harbor.	Enemy submarines, midget submarines, human torpedoes, or torpedo boats in vicinity, or ship torpedoed.	
8	One WHITE light followed by a second WHITE light three minutes later.	At sea during submarine exercises.	Keep clear. My position is as indicated. I intend to carry out surfacing procedure.	Ships are to act in accordance with current instructions in AXP1. See Figure I line 6.

UNCLASSIFIED

ACP130(A)

Line	Signal	Where Used	Meaning	Remarks
Miscellaneous				
9	One WHITE light.	In explosives demolition areas on land.	All Clear.	Only to be used: a. By day only. b. When the nature of the land, or distance, renders other forms of signalling (i.e. whistle or flag) impracticable. c. In conditions of good visibility. By the appropriate notice specified in local regulations. Warning of intended use is to be given to local police, coastguard, hospital and civil aviation authorities. Not to be used over the sea or fired out to sea.
1Ø	A succession of projectiles discharged at intervals of 1Ø seconds, each showing on bursting WHITE lights.	At sea or on land.	To warn aircraft and merchant ships that they are in the vicinity of a restricted area and should change course.	
11	One WHITE light.	From a shore station.	Distress signal or plight observed assistance summoned.	Night. International.
12	A succession of WHITE lights.	From an airfield.	For aircraft on the ground "return to point of departure".	International.

Figure 11-3 - White (Or Yellow)

Line	Signal	Where Used	Meaning	Remarks
1	One ORANGE or one WHITE light.	Airfield.	Local recall.	This signal may also be used in fog or mist or for any other reason to indicate position of airfield.
2	A series of RED and GREEN lights fired simultaneously.	In Convoy.	Convoy will scatter.	
3	A series of RED and WHITE lights fired simultaneously	In Convoy.	Convoy will star.	
4	One RED light followed by one WHITE light.	Fired from aircraft towing target over firing range.	Cease fire, which is endangering me. Recommence firing after checking.	
5	Two WHITE lights followed by one GREEN light	Fired from rescue aircraft during rescue operations.	Rescue successful.	Used only when escorting aircraft accompanies rescue aircraft.
6	Two WHITE lights followed by one RED light.	Fired from rescue aircraft during rescue operations.	Rescue Unsuccessful.	Used only when escorting aircraft accompanies rescue aircraft.
7	Alternate RED and GREEN lights.	From airfield.	General warning signal to aircraft on ground and in the air exercise extreme caution.	International.

Figure 11-4 Miscellaneous Combination Lights

Line	Signal	Where Used	Meaning	Remarks
1	ORANGE smoke	At sea and on land	Distress	Day only
2	One WHITE pyrotechnic smoke.	In explosive demolition areas on land.	Fire.	Only to be used: a. By day only. b. When the nature of the land, or distance, renders other forms of signalling (i.e. whistle or flag) impracticable.

UNCLASSIFIED

ACP130(A)

Line	Signal	Where Used	Meaning	Remarks
				c. In conditions of good visibility. By the appropriate notice specified in local regulations. Warning of intended use is to be given to local police, coastguard, hospital and civil aviation authorities. Not to be used over the sea or fired out to sea.
3	One BROWN pyrotechnic smoke.	In explosive demolition areas on land.	Misfire.	Only to be used: a. By day only. b. When the nature of the land, or distance, renders other forms of signalling (i.e. whistle or flag) impracticable. c. In conditions of good visibility. By the appropriate notice specified in local regulations. Warning of intended use is to be given to local police, coastguard, hospital and civil aviation authorities. Not to be used over the sea or fired out to sea.
4	One WHITE or BROWN smoke puff.	From aircraft in the vicinity of a bombing range.		Used by aircraft engaged in practice bombing exercise for wind finding only.
5	One BROWN smoke puff.	On aerodrome.	Collision imminent.	Used by flying control from the ground. Pilots to fly straight and level until other aircraft sighted, then break away.

UNCLASSIFIED

ACP130(A)

Line	Signal	Where Used	Meaning	Remarks
6	Smoke (by day). Flames (by night) (From a smoke float).	At sea.	Aircraft crashed over the side.	Naval use only.
7	A succession of projectiles fired at intervals of 1Ø seconds each showing on bursting BLACK or WHITE smoke.	At sea or on land.	To warn aircraft that it is in the vicinity of a restricted area and should change course.	By day only.
8	WHITE smoke.	From a shore station.	You are seen. Assistance will be given as soon as possible.	International. By day only.
9	One WHITE (or YELLOW) smoke followed by a second WHITE (or YELLOW) smoke three minutes later.	At sea during submarine exercises.	Keep clear. My position is as indicated. I intend to carry out surfacing procedure.	Ships are to act in accordance with current instructions. See line 1Ø below.
1Ø	One RED smoke repeated as often as possible.	At sea during submarine exercises.	Keep clear. I am carrying out emergency surfacing procedures.	Warning. Submarine may surface simultaneously with RED smoke. Surface vessels are not to stop propellers and shall make RPM for at least 1 1Ø knots. See line 9 above
11	WHITE (or YELLOW) smoke.	On airfield.	Change of runway direction in progress.	By day only.
12.	One WHITE (or YELLOW) smoke.	At sea during submarine exercises.	My position is as indicated.	In response to an underwater signal.

Figure 11-5 - Pyrotechnic Smoke

PYROTECHNIC	IDENTIFICATION
Red Very Flare Cartridge	Raised Cross on top
Yellow/White Very Flare Cartridge	Raised Dot on top
Green Very Flare	Raised Triangle on top
Parachute Flare	Raised letter 'P' on top
Rada Flare	Raised word 'TOP' on top

Figure 11-6 - Very Flare Identification