

TUNER-AMPLIFIER B19

C63

Date of design :- 1937

Frequency range :- 40 - 13,500 Kc/s.

Valves and methods of coupling:- One NR41.
Three VR27 or VR21.

R/F Amplifier - one screened Pentode NR41 (1) Tuned Transformed.
Detector (Cumulative grid) - one VR27 or VR21 (2) Resistance-Capacity
A/F Amplifiers - two VR27 or VR21 (3) (4) L/F Transformer.

Reference :- Admiralty Handbook of W/T (1938)
Section F para.44.

2. Tuner Amplifier B19 was originally designed as a receiver for the transportable set Type 52T, but has been modified and arranged for box mounting in Receiver Outfit CBA with battery supplies as a part of Type 60E, and for rack mounting in Receiver Outfit CBB with battery supplies as the standard emergency receiver equipment.

The receiver consists of one stage of R/F amplification employing a screened pentode valve (1) with two tuned R/F circuits, a cumulative grid detector (2) with variable reaction and two stages of A/F amplification (3) (4).

3. AERIAL CIRCUIT.

An aperiodic aerial is used, the aerial is connected through a semi-adjustable condenser (7) to a fixed tapping on the "Aerial" plug-in range coil (8) which is used as an auto-transformer and in conjunction with the variable condenser (9) forms the tuned grid circuit of the R/F amplifying valve (1).

The condenser (7), whilst it may alter somewhat the tuning of the R/F Grid input circuit, is not itself intended as a means of tuning the aerial; but only of altering the selectivity and signal strength i.e., low values of the condenser (7) will weaken the signal strength but will also reduce the load imposed by the aerial on the tuned grid circuit, thereby giving greater selectivity.

The aerial circuit still remains aperiodic, and the condenser (7) may be set at any position between minimum and maximum value on any wave frequency received.

The condenser (7) is controlled from the front of the receiver by a "Push-Pull" knob marked "Aerial Coupling". A set nut is also provided, to enable the knob to be clamped in any position.

4.

TUNED R/F AMPLIFIER STAGE.

The R/F Amplifier stage consists of a screened pentode NR41 valve (1) with a tuned grid input circuit, consisting of the inductance coil (8) and the variable condenser (9), and an aperiodic anode circuit, consisting of the anode coil (10), which is inductively coupled to the the inductance coil (11) of the detector valve (2) tuned R/F grid input circuit.

The variable condenser (9), which has a maximum value of 0.003 mfd, is controlled from the front of the receiver by a vernier dial marked "R/F".

The inductance coils (8), (10), (11) consist of plug-in range coils.

The anode of the R/F valve (1) is connected to the top of the anode coupling coil (10). The bottom of the coil is connected to earth by a 0.25 mfd. condenser (19) and to the H.T. line through the 2000 ohm voltage reducing resistance (18).

The screen grid of the valve is decoupled to earth by a 0.25 mfd. condenser (17) and connected to the screen grid supply line through the 2500 ohm voltage reducing resistance (16).

5.

PLUG-IN RANGE COILS.

Two sets of seven plug-in range coils are used to cover the frequency ranges as follows :-

TUNER-AMPLIFIER B19

RANGE COIL.	FREQUENCY RANGE KC/S.
0	40 - 100
1	100 - 250
2	250 - 600
3	600 - 1,500
4	1,500 - 3,000
5	3,000 - 6,000
6	6,000 - 13,500

One set, marked "Aerial" and consisting of the inductance coil (8), is used for the tuned grid input circuit of the R/F amplifier valve (1) and the other set, marked "Det" for the tuned grid circuit of the detector valve (2). The latter comprise the R/F valve anode inductance coil (10), detector grid tuning inductance coil (11) and reaction coil (12).

Range coils not in use are stowed in a metal container which fits into the receiving rack alongside the receiver.

6. DETECTOR STAGE AND REACTION.

The detector valve (2) operates on the cumulative grid principle in conjunction with the 0.0001 mfd. grid condenser (14) and a 2 megohm grid leak resistance (15).

The tuned grid input circuit consists of the inductance coil (11) and variable condenser (13). The tuning condenser (13) has a maximum value of 0.0003 mfd. and is controlled from the front panel of the receiver by a vernier dial marked "Detector".

Capacity controlled magnetic reaction is employed to increase signal strength when receiving I.C.W. signals and for autodyning when receiving C.W. signals.

The amount of reaction used is governed by a differential condenser (24) which is adjusted from the front of the panel by a vernier dial marked "Reaction". This condenser controls the feed to the reaction coil (12).

By using a differential condenser, connected as shown in Fig. 3 the capacity between anode and filament of the detector valve (2) is maintained at a constant value for any setting of the condenser (24) for reaction purposes. This method prevents the grid tuning of the detector valve (2) from being affected by any alteration of the reaction condenser.

The anode of the detector valve (2) is connected to the H.T. line through a 10,000 ohm resistance (20), a 50,000 ohm load resistance (21) and a 20,000 ohm voltage reducing resistance (22). A 1 mfd. decoupling condenser (23) is connected between the junction of resistance (21) and (22) and earth. The 10,000 ohm resistance (20) takes the place of the usual R/F choke coil to enable smooth reaction to be obtained over the whole frequency range of the receiver.

7. A/F STAGES.

A resistance-capacity coupling circuit, consisting of the 50,000 ohm coupling resistance (21), a 0.01 mfd coupling condenser (25) and the grid leak resistance (26), is used between the detector valve (2) and the first A/F amplifying valve (3).

A filter circuit, consisting of two 100,000 ohm resistances (27) (28) and two 0.0002 mfd. condensers (29) (30) is included in the grid input circuit of the first A/F amplifying valve (3) to reduce to a minimum the amount of R/F voltage passed on to the grid of the A/F valve (3).

An audio-frequency transformer (31) is used to couple the first and second A/F stages and a telephone transformer (34) is connected in the anode circuit of the second A/F amplifying valve (4).

The anode of the first A/F amplifying valve (3) is connected to the H.T. line through the primary of the A/F transformer (31) and voltage reducing resistance (32). A 1 mfd. decoupling condenser (33) is connected between the junction of the primary of the A/F transformer and resistance (32) and earth.

TUNER AMPLIFIER B19

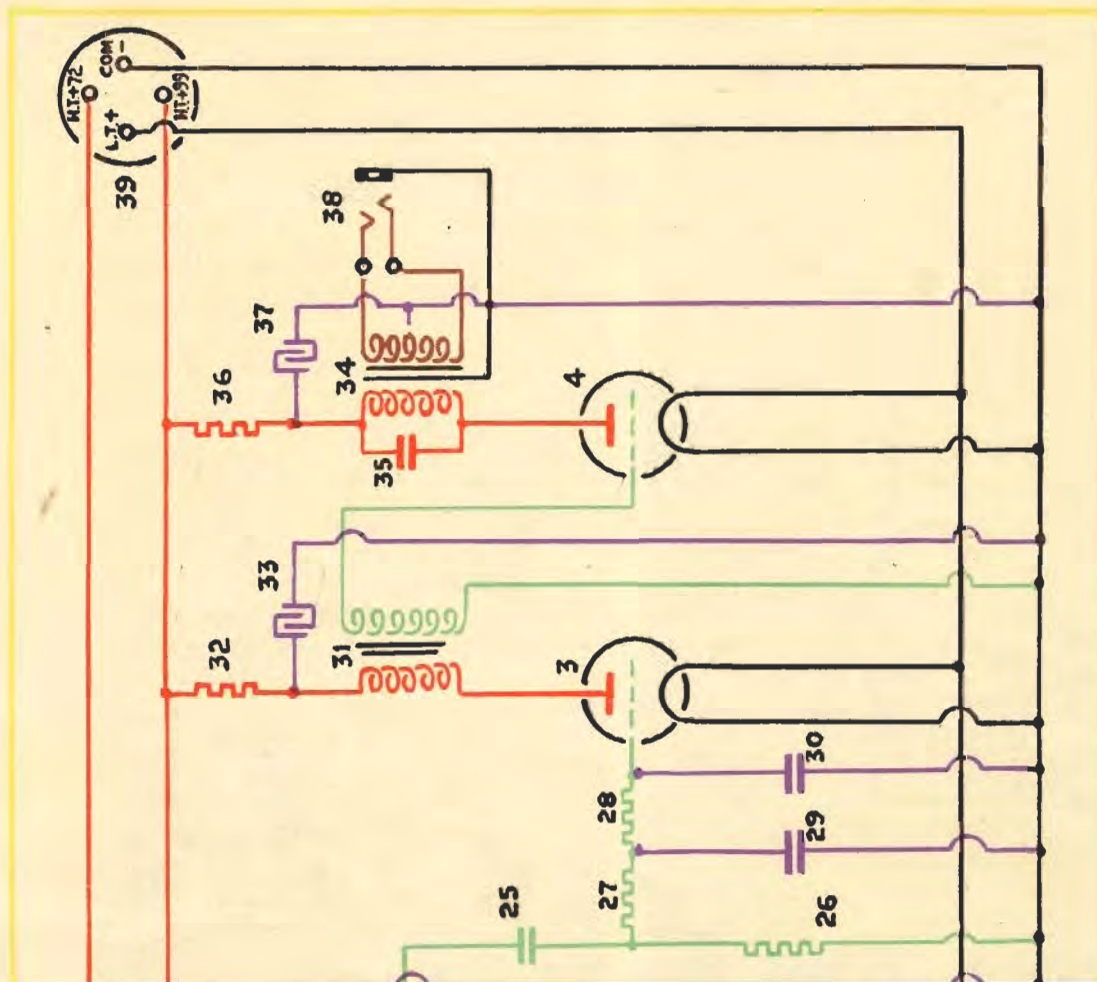

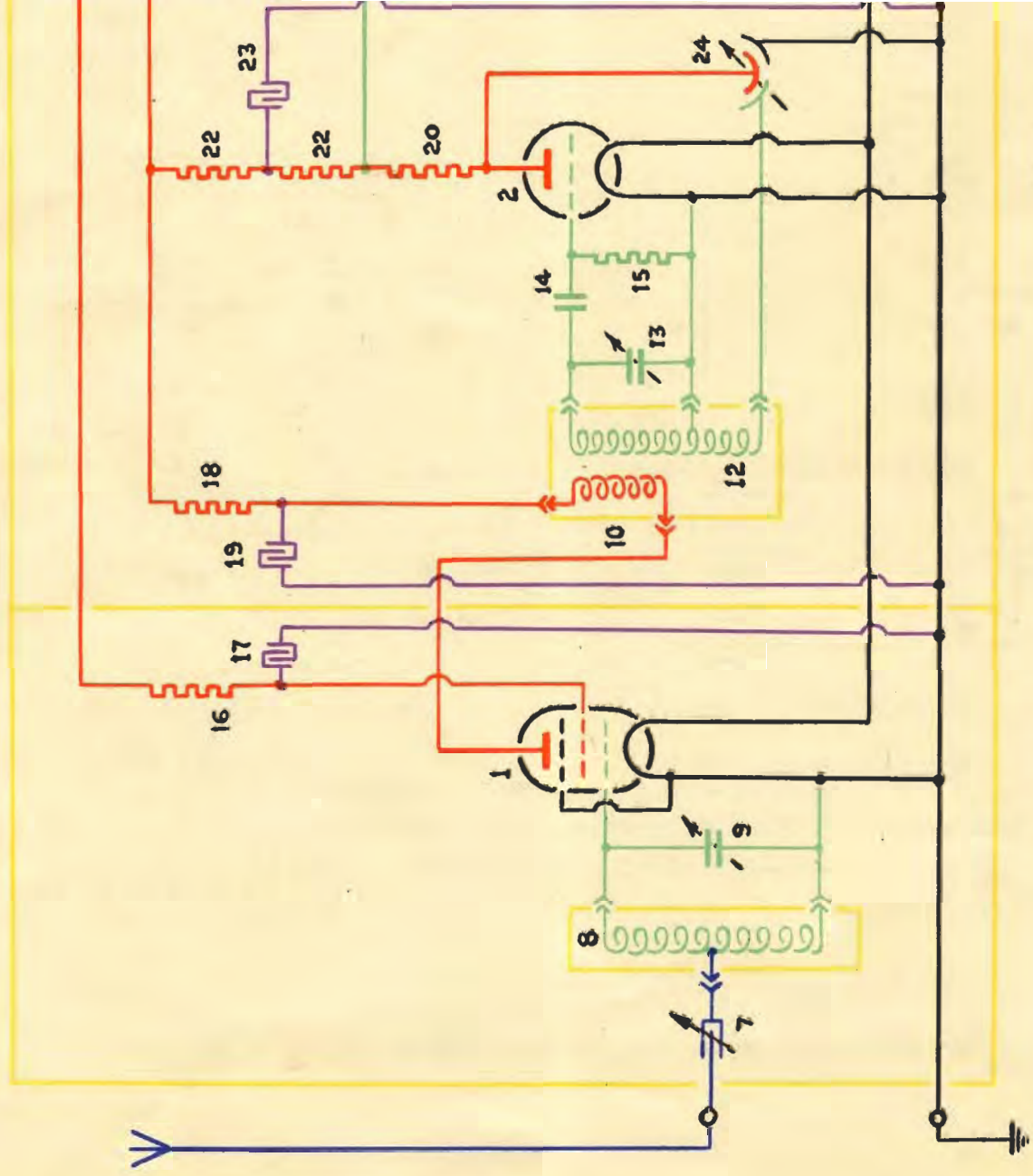

FIG. α.

TUNER-AMPLIFIER B19

C65

The anode of the output valve (4) is connected to the H.T. line through the primary of the telephone transformer (34) and a 50,000 ohm voltage reducing resistance (36). A 1 mfd. decoupling condenser (37) is connected between the junction of the telephone transformer primary and resistance (36) and earth. A .001 mfd. R/F by-pass condenser (35) is connected across the primary of the telephone transformer (34). The secondary of the telephone transformer (34) is connected to the telephone jack (38) which is fitted on the front panel of the receiver.

Earth connections are made to the iron core of the telephone transformer, to a centre tap on the secondary and to the ring contact on the telephone jack.

8. H.T. AND FILAMENT SUPPLIES.

The filament supply is obtained from a Pattern 6706, 2-volt accumulator battery and the H.T. supply from a Pattern 3774, 99-volt dry cell battery (47).

The H.T. battery is tapped at 72-volts for supplying the screen of the R/F amplifying pentode valve (1).

Two Pattern 6706, 2-volt accumulators (51) (52) are provided and should be fitted in the acid tight compartment (46) which forms part of the Pattern 4707 Battery Control Unit 4T.

The Battery Control Unit, which is designed to fit in the receiver rack alongside the receiver, also contains the H.T. Battery and switching arrangements for the 20-volt emergency lighting (44) and for charging (45) the 2-volt L.T. batteries from the 20-volt ship's mains through a Pattern 5519 25-volt, 25 watt lamp (50). The lamp also acts as a "Filament Battery Charge Indicator".

The switch (44) is fitted with a reversible ivory label showing four positions of the switch (i.e. "Max 4-volt Charge", "Off", "Lights", "Lights and 4-volt Charge") on one side, and two positions (i.e. "On" and "Off") on the other side.

The four position side is used when Patt. 4707 Battery Control Unit is fitted as a component of Receiver Outfit CBA, and the two position side with Receiver Outfit CBB.

The positions marked "Max 4-volt Charge" and "Lights and 4-volt Charge" are used in conjunction with Type 60E for charging the 4-volt filament battery of the Transmitter 4T.

The ivory label, which is slotted, is reversed by removing the three securing screws in the metal surround and sliding upwards.

The metal tally above the switch is also reversible, being marked "Emergency Lights" on one side for use when the switch is used in two positions, and "Lighting" the "4-volt Charge" on the other side for use when the switch is used in four positions.

The H.T. negative and L.T. negative leads are made common on the terminal block inside the battery control unit. The four connections between the battery unit and the tuner amplifier B19. (i.e. H.T. + 99-volts, H.T. + 72-volts, L.T. + 2-volts and common negative) are made by means of a 4 core flexible lead and 4-pin socket (40) which is connected to the 4-pin plug (39) fitted on the front panel of the tuner amplifier B19.

The connections to the socket from the battery control unit are as follows :-

H.T. + 99-volts	-	Green lead	-	Anode pin of socket
H.T. + 72-volts	-	White lead	-	Grid pin of socket
Fil. + 2-volts	-	Blue lead	-	Right-hand fil: pin of socket.
Common negative	-	Black lead	-	Left-hand fil: pin of socket.

9. OPERATION.

- (a) See that the appropriate aerial is connected to the receiver
- (b) Plug in appropriate aerial and detector tuning range coils for the required wave-frequency.
- (c) Set "Receiver Fil: Batts" switch (45) on the Pattern 4707 Battery Control Unit to the appropriate filament battery.

NOTE :- This will put the other filament battery on charge.

- (d) Check filament supply voltage by the voltmeter (41) on the Battery Control Unit.

TUNER AMPLIFIER B19

BATTERY CONTROL UNIT 4T
CIRCUIT DIAGRAM

Fig. 2.



- (e) Connect battery control unit socket (40) to the plug connection (39) on the Tuner Amplifier B19.
- (f) Set the detector tuning condenser (13) to the approximately correct position by reference to the tuning curves.
- (g) Adjust the reaction condenser (24) so that the detector is just oscillating for C.W. reception and just NOT oscillating for receiving I.C.W. signals.
- (h) Set the "Aerial Coupling" condenser (7) to approximately 50% coupling, (i.e. sliding condenser adjustment about mid-way).
- (j) Adjust the "R/F" Tuning condenser (9) for maximum "mush" in the telephones.
- (k) Search slowly on either side of the approximate adjustment of detector tuning condenser (13) until the required signal is heard, when this is done readjust "R/F" tuning condenser (9), if necessary, for maximum signal strength in the telephones.
- (l) Strength of received signal may be controlled, within limits, by varying the aerial coupling.

Note:- This may necessitate a slight readjustment of the "R/F" tuning condenser (9).

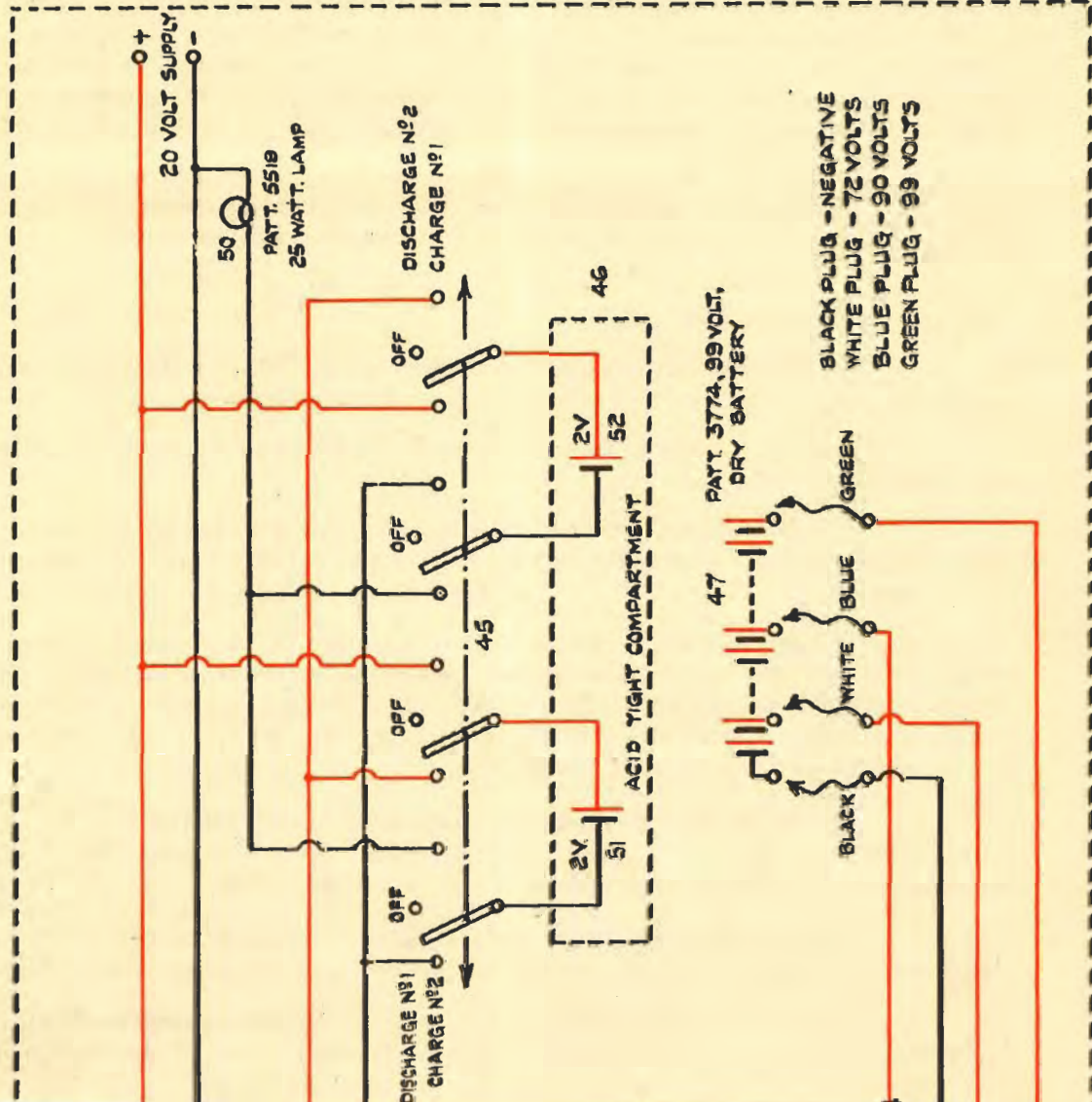
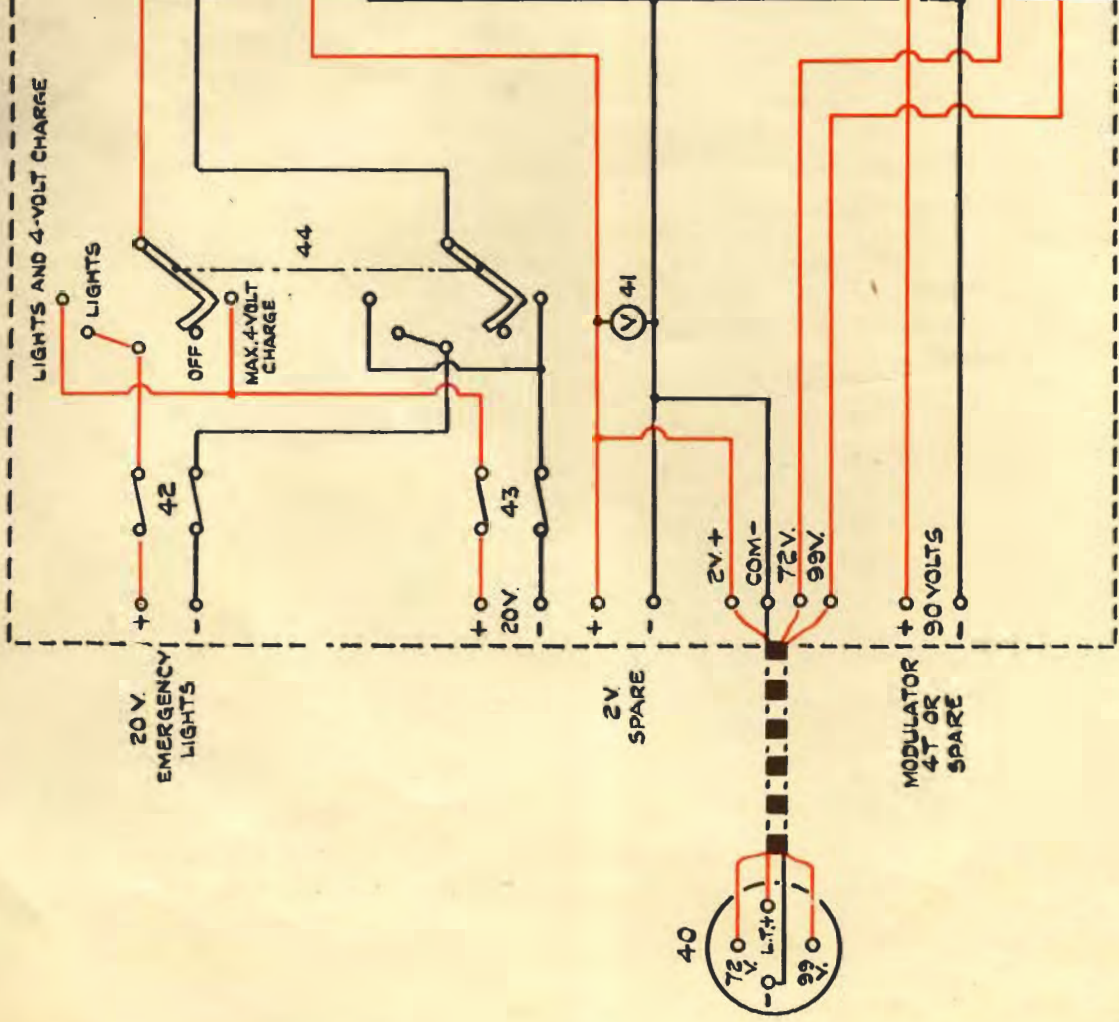
FRONT PANEL VIEW

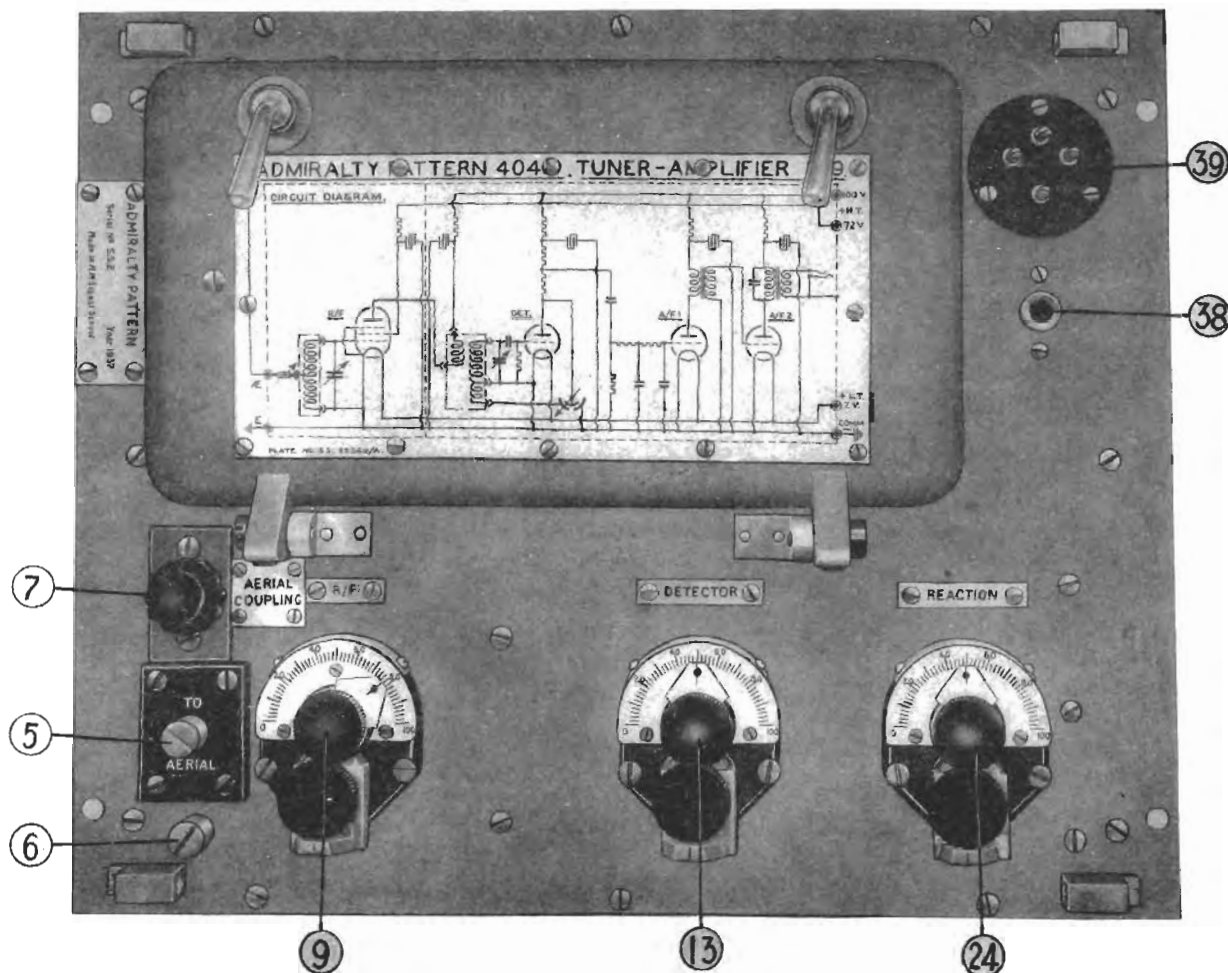

TUNER-AMPLIFIER B19
PATT. 4707 BATTERY CONTROL UNIT 4T
FRONT VIEW

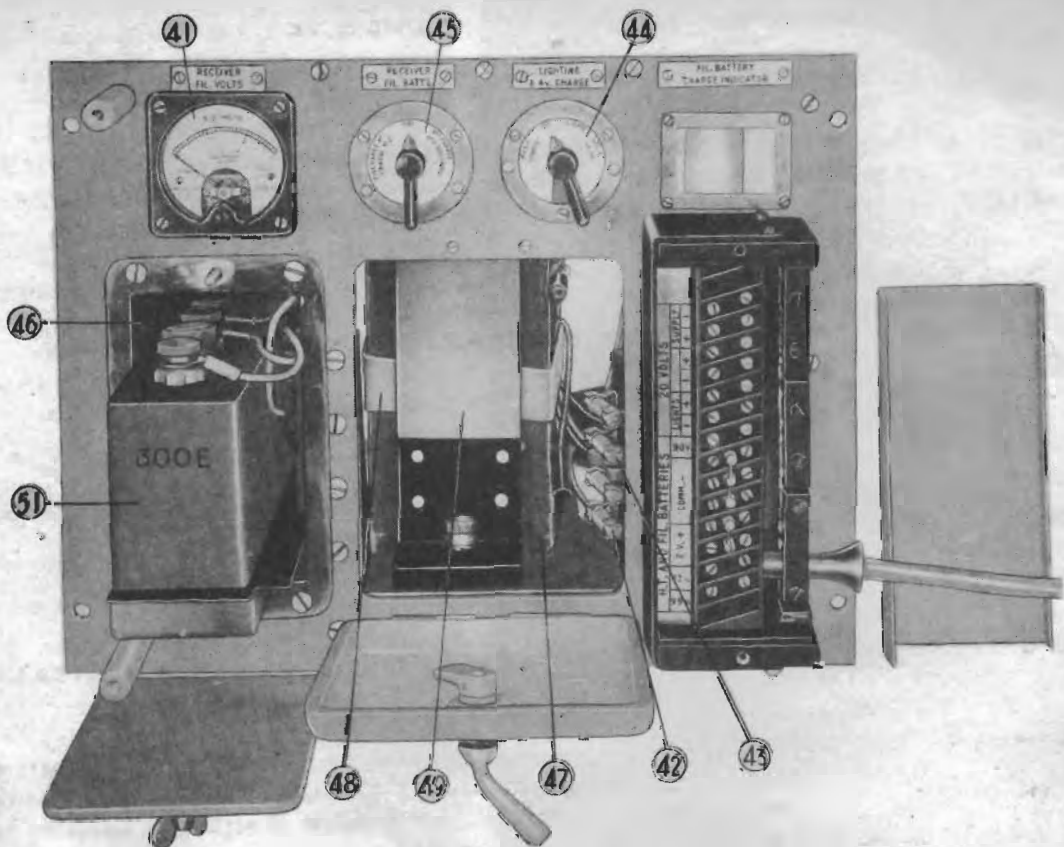

Fig. d

TUNER AMPLIFIER B19
AERIAL AND DETECTOR PLUG-IN RANGE COILS

