

GC10

OSCILLATOR G 35

FRONT VIEW

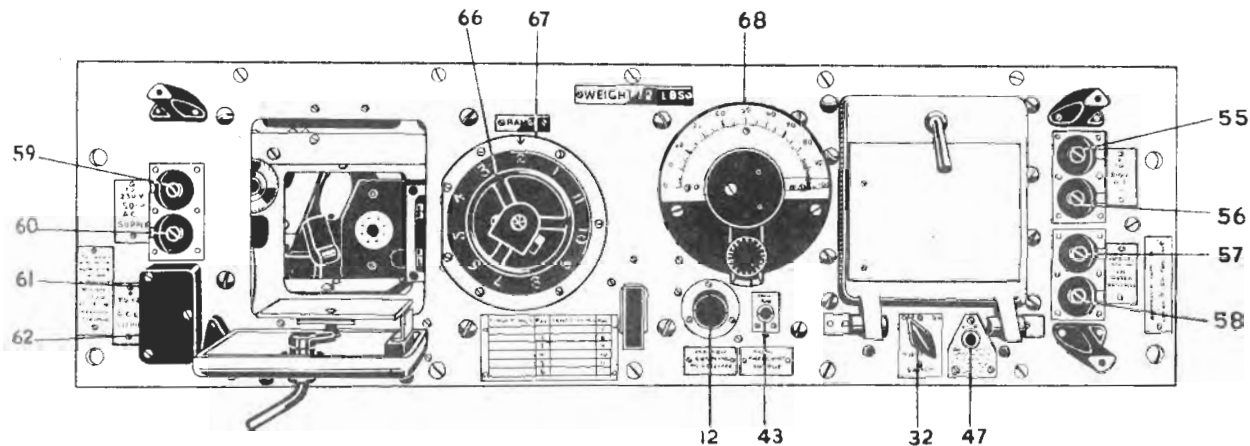

FIG b

OSCILLATOR Q 35

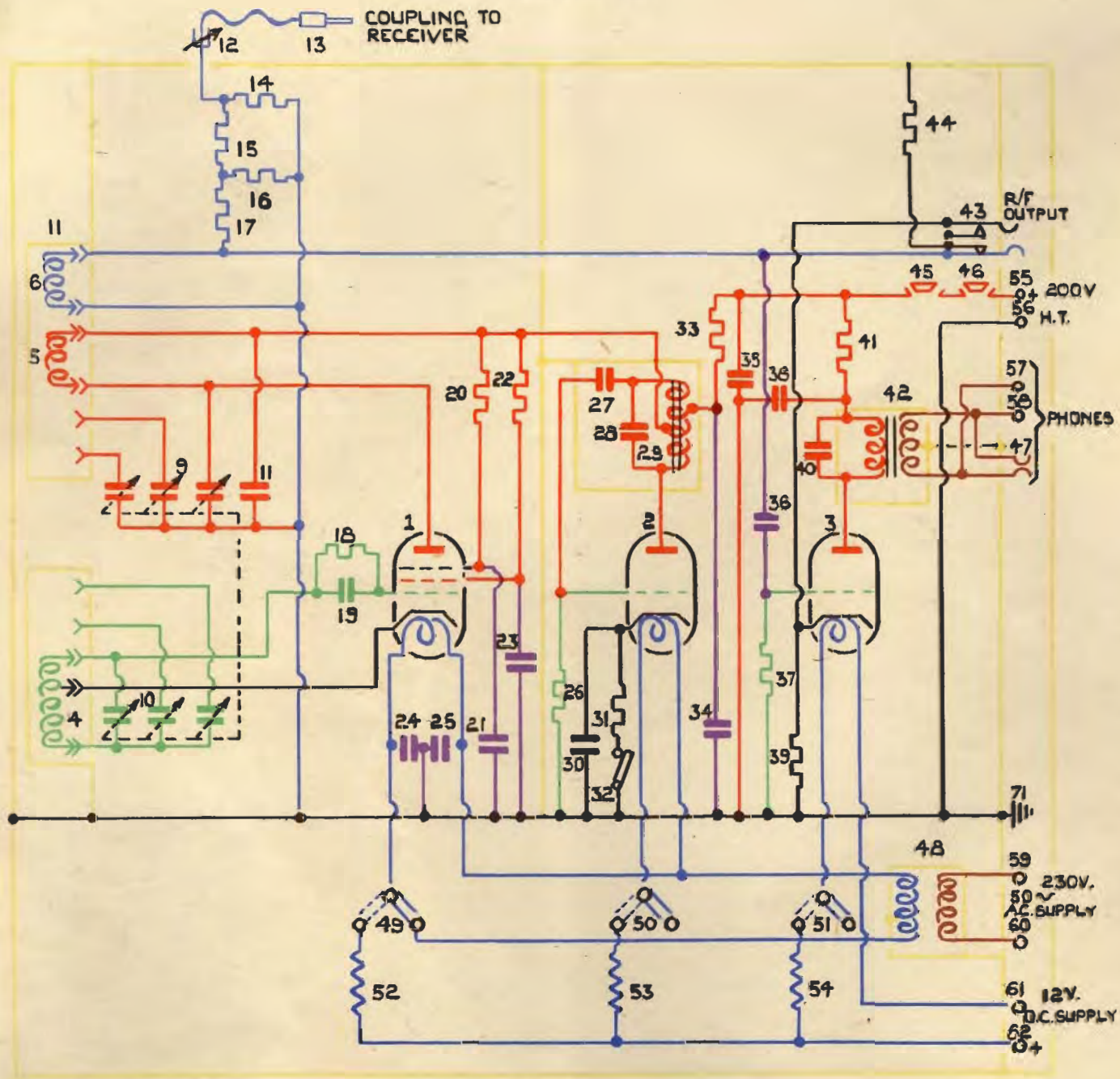

FIG C.

OSCILLATOR G35

GC9

Date of Design :- 1938
Frequency Range :- 15 to 25,000 kc/s.
Valves used :- Oscillator Valve = one NR49
Modulator Valve = one NR48
Detector Valve = one NR48
Reference :- Admiralty Handbook of W/T (1938) Vol. II. Section W.

Oscillator G35 is used to provide oscillations for the following purposes :-

- (i) As a C.W. or M.C.W., local oscillator for setting a receiver to a desired frequency.
- (ii) As a heterodyne wavemeter in conjunction with a receiver to measure the frequency of an incoming signal.
- (iii) As a heterodyne receiver to measure the frequency of a local transmitter.

In conjunction with H/F wavemeter G61 and M/F wavemeter G62, it constitutes Wavemeter Outfits GH to GJ and GL. Wavemeter G61 in conjunction with Oscillator G35 constitutes Wavemeter Outfit GK.

As the calibration of Oscillator G35 is not maintained to a high degree of accuracy no tuning curves are provided but a high degree of accuracy is obtained by using this oscillator in conjunction with wavemeter G61/62 using the latter for frequency measurement.

The frequency band 15 to 25,000 kc/s is covered in 11 ranges as indicated below

Range	Kc/s.	Range	Kc/s.
1	15 - 25	7	800 - 1,600
2	25 - 50	8	1,600 - 3,000
3	50 - 100	9	3,000 - 6,000
4	100 - 200	10	6,000 - 12,000
5	200 - 400	11	12,000 - 25,000
6	400 - 800		

Two ganged inductance coils (4) (5), one for the grid circuit and one for the anode circuit are used for each wave band and are mounted on two turrets on a common spindle, operated from the front panel by a turret wheel (66) marked "Range", the range number in use is that opposite the arrow mark. Tuning Condensers. The anode and grid coils in use are tuned by two variable condensers (9) (10) whose spindles are ganged and are operated by the tuning dial (68) marked "Oscillator Tuning".

To prevent interaction between adjacent coils the grid coils (4) for the two previous ranges and the anode coil (5) for the range previous to that in use are short-circuited by contacts (63) (64) (65) mounted on the turret screening boxes. (See Fig. a).

OSCILLATOR G 35

RANGE COIL FORMERS & TURRET BOXES

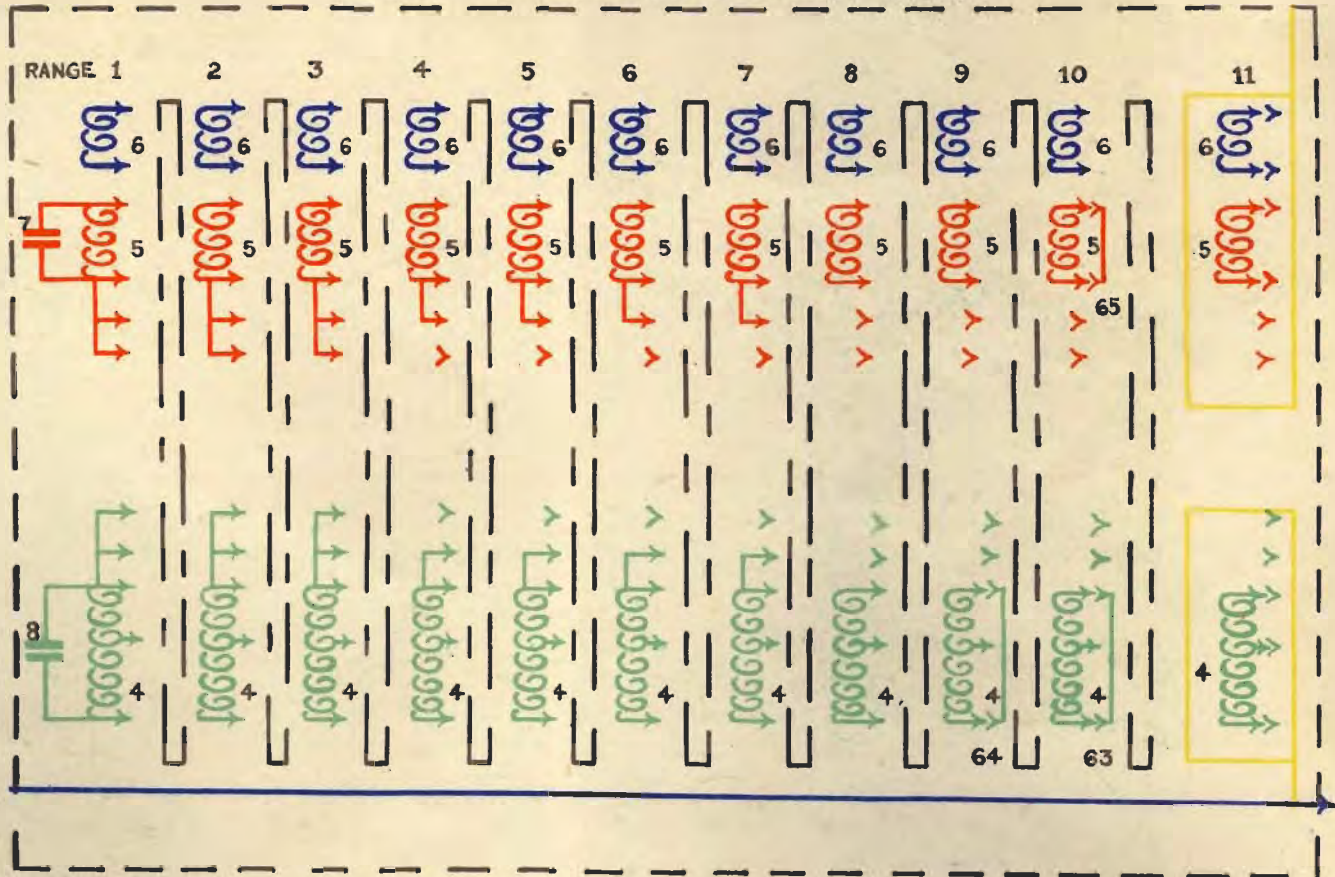

FIG 2

OSCILLATOR G35

GC11

Oscillatory Circuits. The Oscillator valve (1) functions as an electron-coupled oscillator. The cathode, control grid and screen grid are connected as a triode oscillator to a Hartley series feed circuit consisting of the grid inductance coil (4), grid tuning condenser (10), grid leak condenser (19) and resistance (18), and the 0.1 mfd. condenser (23). The screen grid is supplied with H.T. through a 100,000 ohms resistance (22).

The anode circuit consists of the anode inductance coil (5) and anode tuning condenser (9) which is connected across the anode coil (5) through the fixed condenser (11) of 0.1 mfd. The anode circuit is coupled to the oscillatory circuit through the valve (1) electron stream, and capacity coupling between the two circuits is reduced by the suppressor grid, which acts as a screen.

The suppressor grid is supplied with H.T. through the 1,000-ohms resistance (20) which, in conjunction with the 0.1 mfd. condenser (21) also functions as a decoupling unit.

Coupling Coil. The R/F output is derived from the anode circuit by means of a coupling coil (6) which is wound over each anode coil (5) in each range unit. The coupling coil (6) is connected to the ring of the R/F output jack (43) fitted on the front panel. A single-cored insulated flexible wire cord with a plug at each end is used for connecting the Oscillator G35 R/F output jack (43) with the Wavemeter G61/62 R/F input jack, the return circuit being completed by an earth return. When connected thus, the coupling coil is terminated by the 100-ohms input resistance of the wavemeter; when the plug is withdrawn from the G35 Oscillator R/F output jack (43) the coupling coil is connected via the R/F output jack ring inner through a 100-ohms resistance (44) to earth.

The coupling coil (6) is also connected to a fixed attenuator unit consisting of a network of resistance units; two 2,000-ohms resistances (15) (17) forming the series arms and two 100-ohm resistances (14) (16) the shunt arms of the attenuator unit. The attenuation of this unit is approximately 60 decibels. (See Admiralty Handbook of W/T (1938), Volume II, Appendix (A).)

R/F Output. The attenuated output of the Oscillator G35, which is suitable for supplying a R/F voltage at any wave frequency within the range of the oscillator to receiver inputs, is connected to the receiver coupling socket (12) marked "Variable Coupling to Receiver".

The Receiver Aerial input jack is coupled to the Oscillator G35 by the special plug and cord (13) provided. The plug forms a capacity coupling made variable by sliding it further into or out of the socket. The coupling unit (12) is indicated as a variable condenser in Fig. b. When the plug is pushed right in it makes contact with the attenuator output and short circuits the coupling capacity.

Heterodyning. To enable a local transmitter to be tuned by the heterodyne method the R/F coupling coil (6) is connected through a 200 mmfd. condenser (36) to the grid of the detector valve (3) which is returned to earth by the resistance (37) of 100,000 ohms. For this purpose the transmitter is connected to the detector valve cathode via the transmitter Wavemeter Exchange, the wavemeter G61/62 "Transmitter Coupling" terminals and the tip circuit of the insulated flexible twin-core cable provided for connecting the wavemeter G61/62 to oscillator G35. The circuit is completed by an earth return.

The resistance (39) of 100-ohms provides a suitable bias for the detector valve (3), and also a correct termination for the transmitter coupling circuit.

The anode of the detector valve (3) is connected to the primary of a screened telephone transformer (42) which is shunted by a 0.001 mfd. condenser (40) to by-pass the R/F currents. The anode circuit of the detector valve is decoupled by resistance (41) of 50,000 ohms and condenser (38) of 1 mfd.

The secondary of the telephone transformer (42) is connected to a jack (47) marked "Phones, For Wavemeter Transmitters and Incoming Signals on Receiver by Heterodyne Method". Telephone receivers plugged into this jack enable the beat note to be heard.

Modulator Circuit. The R/F output may be modulated at 500 cycles by the audio frequency oscillator valve (2), a Hartley series feed circuit being used. A choke (29) is tuned to approximately 500 cycles by a condenser (28) of 0.03 mfd. in conjunction with the capacities from other parts of the circuit. Back coupling to the grid of the valve (2) occurs through the blocking condenser (27) of 0.1 mfd., and the grid is returned to earth through a resistance (26) of 100,000-ohms.

A switch (32), completes the modulator circuit by earthing the cathode bias resistance (31) of 2,500-ohms, condenser (30) of 1 mfd. being used as a R/F by-pass.

OSCILLATOR G35

POWER SUPPLIES — OPERATION

Power Supplies. A 200-volt H.T. supply is required for oscillator G35 and is normally obtained from a pattern 1204B Stabilised Rectifier unit which also supplies wavemeter G61/62.

Safety switches (45) (46) are fitted, one on each valve access door, which break the H.T. positive lead when the doors are opened. The H.T. supply is decoupled by two 1 mfd. condensers (34) (35) and a resistance (33) of 1,000-ohms.

A 230-volt, 50-cycles supply is required for heating the filaments of the valves. This supply is fed to a screened transformer (48) fitted inside the oscillator G35 and stepped down to 6 volts by the secondary the centre point of which is earthed. Two condensers (24) (25) of 0.1 mfd. are connected between the filaments and earth to reduce hum.

Alternative Filament Supply. The filaments may alternatively be supplied from a 12-volt battery connected to terminals (61) (62). For this purpose three links (49) (50) (51), fitted inside the instrument, are provided and must be changed over to the appropriate positions marked "12 V". The alternative supply is then passed through three 30-ohm resistances (52) (53) (54), one in the positive lead to each filament, to reduce the voltage to 6 volts. The negative 12-volt supply terminal is connected to earth via the secondary of the filament transformer (48).

I. To calibrate or Tune a Receiver to a Desired Frequency.

- (a) Insert the appropriate plug in the Oscillator G35 "Variable coupling to Receiver" socket (12). If the receiver is connected to the Aerial Exchange, insert jack plug end of cord in top-most jack for the appropriate aerial. If a local receiver is being set, insert jack plug in the local receiver jack (situated beneath wavemeter transmitter exchange), and put wavemeter coupling switch on pattern 4835 wavemeter coupling box to "ON".
- (b) See that one end of the cord for connecting wavemeter G61/62 and oscillator G35 is inserted in the G35 R/F output jack (43) and the other end in G61 or G62 according to the wave frequency range required.
- (c) Set wavemeter G61/62 to the required frequency.
- (d) Turn the oscillator G35 turret wheel (66) to the range which covers the required frequency.
- (e) Turn the tuning dial (68) to its maximum clockwise setting (mark 100) and then turn it slowly anticlockwise until a deflection is obtained on the wavemeter milliammeter. Obtain the final setting on the slow-motion dial. It is important to follow this procedure to avoid false setting, due to harmonics of the G35, or to a second reading on the G61/62 (See wavemeter G61/62 instructions).
- (f) The receiver is tuned to the oscillations. 500 cycles modulation may be applied by switching the G35 modulation switch (32) to "ON". The strength of oscillations may be varied by sliding the variable coupling plug in its socket (12) on the G35.

II. To measure the Frequency of an Incoming Signal.

- (a) Insert connections as in 1 (a) and (b).
- (b) Tune the receiver to the incoming signal.
- (c) Tune the oscillator G35 as in 1 (d) and (e) until a beat note is heard in the telephones, and tune to the dead space of this note.
- (d) Measure the frequency of the G35 on the wavemeter G61/62.

III. To measure the Frequency of a Local Transmitter. The Oscillator G35 may be used to measure the frequency of a local transmitter by the heterodyne method. The connections are the same as for tuning the transmitter on the wavemeter G61/62. (See Handbook of Instructions for Wavemeter G61 and G62), and the beat note between the oscillator G35 and the local transmitter may be heard by inserting telephone receivers in the phones jack (47) on the G35 or at the Transmitter Room Wavemeter panel. The G35 is tuned to the dead space and the frequency measured on the Wavemeter G61/62.

The method is not recommended for small transmitters as the G35 is liable to "Pull" the transmitter off its frequency. It is preferable to tune a receiver to the transmitter, and set the G35 to the same frequency as in para. 2 above.