

# WAVEMETERS G61-62

GD11

Date of Design:- 1937.  
Frequency range:- G61:- 1,000 - 24,000 kc/s (in 5 ranges).  
G62:- 15 - 2,500 kc/s (in 8 ranges).  
Indicator:- Triode valve and milliammeter. (See Admiralty Handbook of W/T (1938 Vol. II. W. + 1 kc/s (G61) (See Admiralty Handbook of W/T (1938) Vol. II Section W.9. ± 0.1 kc/s (G62).  
Valves used:- One NR48 = Crystal Controlled Oscillator.  
One NR48 = Harmonic Selector Valve Oscillator.  
Two NR48 = "Heterodyne Beat Note Amplifier" (1 Detector, 1 A/F Amplifier).  
Five NR48 = Interpolating Absorption Wavemeter. (4 coupling, 1 Detector).

Note:- NR48 valve is a double diode triode, but the triode portion only is used in G61.

Wavemeters G61 and G62 in conjunction with Oscillator G35 constitutes Wavemeter Outfits GH to GJ and GL. Wavemeter G61 in conjunction with Oscillator G35 constitutes Wavemeter Outfit GK. Capabilities and Principle of Wavemeters. Wavemeters G61 and G62 may be used for tuning a transmitter to a required frequency or, in conjunction with Oscillator G35, for measuring the frequency of incoming signals and calibrating receiver outfits.

Note:- Throughout this section the fundamental frequency for each wavemeter when using crystal oscillator is:- G61 = 1,000 kc/s, G62 = 100 kc/s.

Both G61 and G62 contain a crystal (20) controlled valve (1) oscillator which is maintained accurately at 1,000 kc/s and 100 kc/s respectively by enclosing the crystal in a thermostatically controlled oven (24).

The crystal oscillator is used accurately to tune, by the heterodyne "Dead-Space" method, a self excited valve (2) oscillator (harmonic selector) to integral multiples of the fundamental frequency. To facilitate this, the quartz crystal and harmonic selector oscillators are coupled to the grid input circuit of a two stage amplifier (1 DET (8), 1 A/F Amp. (9) ), to which may be connected a pair of telephones.

The "Harmonic Selector" circuit is calibrated in integral multiples of the fundamental frequency and controlled by a variable condenser (34) and operated in conjunction with a range coil switch (32).

The frequency to be measured is fed into a special push-pull coupling circuit and is mixed with a suitable multiple of the fundamental frequency which is also fed into the coupling circuit from the "Harmonic Selector" oscillator. The RESULTANT heterodyne beat frequency between the unknown frequency and the selected multiple of the fundamental frequency is measured by an interpolating absorption wavemeter similar to the Wavemeter G56.

General description. Wavemeters G61 - G62 comprise the following three sections :-

- (a) A quartz crystal-controlled oscillator.
- (b) A harmonic selector self-excited oscillator and a two stage "Heterodyne Beat" note amplifier.
- (c) An interpolating absorption wavemeter having a frequency range of G61 1000 to 2000 kc/s.  
G62 15 to 200 kc/s.

Normal arrangements for decoupling and biasing the grids and cathodes of the valves are used.

The only difference between G61 and G62 other than frequency range, is that in the former the resistance in the parafed coupling between the two valves of the Heterodyne Beat Note amplifier is increased on the higher frequencies by one contact of the "thousand selector switch".

Each wavemeter is designed to fit in a standard receiving rack.

Crystal controlled oscillator (Fig. a). This consists of an indirectly heated NR48 valve (1) with tuned anode circuit (10) and (11) and oscillator employing either a 1000 kc/s or 100 kc/s quartz crystal (20) control. (See Admiralty handbook 1938, Vol. II, Sect. K42, 45). The crystal is maintained at a temperature of 50°C by being enclosed in an electric thermostatic oven. A small pre-set variable condenser (19) is connected in parallel with the crystal, for the purpose of fine frequency control and is capable of adjusting the 1000 kc/s crystal within 1 kc/s and the 100 kc/s crystal within .01 kc/s with the oven at a steady temperature of 50°C. This setting should not be altered after the instrument is calibrated at H.M. Signal School.

Link (15) connects two terminals which are used for inserting a milliammeter in the anode circuit when investigating the behaviour of the various crystals and are not required when the wavemeter is in service.

# QUARTZ CRYSTAL-CONTROLLED OSCILLATOR

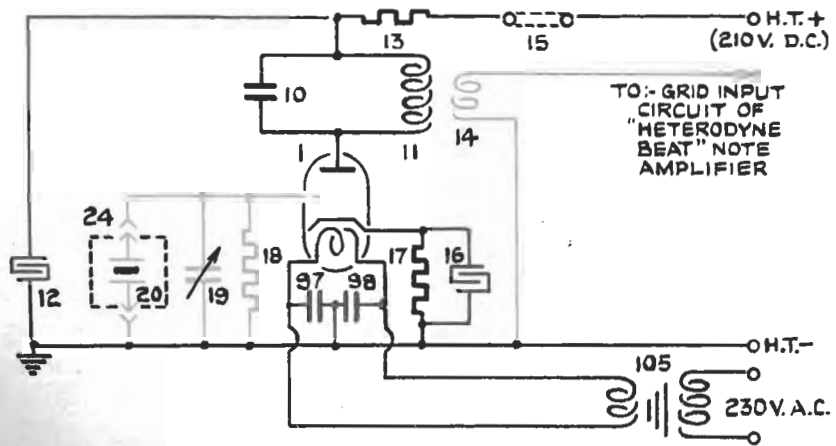

Fig. a.

## WAVEMETERS G61-62

Harmonic Selector Oscillator (Fig. b). This consists of a self-excited valve oscillator employing an indirectly heated NR48 valve (2) and includes a number of grid (31) and anode (33) tuning coils, the appropriate coils being selected by a range switch (32). The selected anode coil is tuned by a variable condenser (34) in parallel with it, controlled by a vernier dial marked "Thousands Selector" (G61) or "Hundreds Selector" (G62). The harmonic selector oscillator may be tuned to any particular multiple of the fundamental frequency by setting the selector switch (32) to the appropriate range, and with slow motion dial (34) to tune to the dead space of the Heterodyne beat note heard in the telephones, the output of this circuit is fed to the heterodyne beat note amplifier by one half of condenser (29). When the selector range switch (32) is set to range 1 in the case of G61 and 1 to 4 in the case of G62 the harmonic selector valve oscillator is cut out entirely by breaking the H.T. supply to the valve (2). Any frequency between

1000 and 2000 kc/s      G61

15 and 200 kc/s      G62

can then be measured directly on the interpolating absorption wavemeter. The anode supply to the harmonic selector oscillator is decoupled by a 20,000 ohms resistance (56) and 0.01 mfd. condenser (35).

"Heterodyne Beat" Note Amplifier (Fig. c). This consists of a detector (8) and A/F amplifier (9) coupled to both the crystal controlled oscillator and harmonic selector oscillator, and serves to facilitate the accurate tuning of the self excited oscillator to definite integral multiples of the fundamental frequency. The "Parafed" (See Admiralty Handbook of W/T (1938) Vol. II, Sect. F.19) method of coupling is used between the detector valve (8) and amplifier valve (9) and consists of the anode resistance (38), (in G62 this is resistance (38) but in G61 it consists of two resistances (38) and (39) connected in series, switch (32) ganged to the "Thousands Selector" switch brings one or both of these resistances into the parafed coupling system.)

A second parafed coupling, consisting of the anode resistance (51), coupling condenser (52) and A/F transformer (53) is employed for feeding the output of the A/F valve to the telephones used for the "Heterodyne Beat" note "dead space" tuning. The secondary of the transformer (53) being connected to the telephone jack (55).

## HARMONIC SELECTOR OSCILLATOR

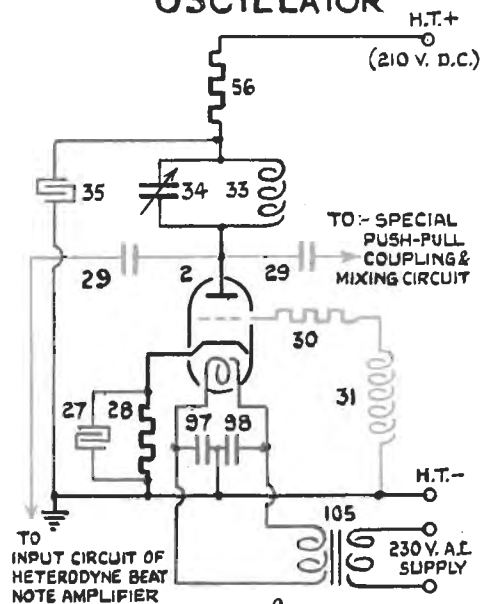

FIG. B.

## HETERODYNE BEAT NOTE AMPLIFIER

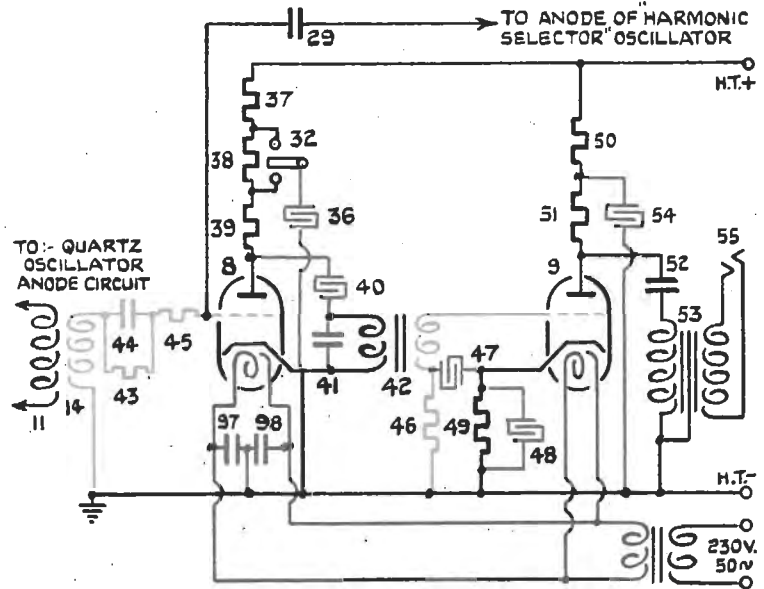

FIG. C.

Interpolating absorption wavemeter. This is situated on the right hand side of the instrument and comprises :-

- (a) A balanced push-pull coupling circuit.
- (b) The wavemeter.

**Coupling Circuit.** The coupling circuit is employed for mixing the unknown wave-frequency with the particular harmonic of the fundamental frequency selected, and then applying the heterodyne beat frequency to the wavemeter. A system of balanced valve (3) and (4) is employed to exclude harmonics from the wavemeter. (Admiralty Handbook of W/T (1938) Vol. II, Sect. F27.)

The grid coil (60) of the coupling circuit is centre tapped to the harmonic selector the signal it is desired to measure is coupled inductively to the grid coil by coil (59).

The heterodyne beat frequency is applied to the wavemeter via the coupling circuit anode coil (71) which is inductively coupled to the wavemeter coupling coil (72). The balancing of the coupling circuit is effected by adjusting the cathode bias by means of a potentiometer resistance (64) marked "Valve Balance Adjustment". The procedure for balancing :-

- (i) With no transmitter (or Oscillator G35) connected to the wavemeter, set the "Hundreds Selector" (G62) "Thousands Selector" (G61) dial of the harmonic oscillator to No. 3 graduation mark and the "Hundreds - Thousands Selector" switch to range (2 with G61) and (5 with G62).
- (ii) With the "Valve Balance Adjustment" well off its centre position, set the wavemeter tuning condenser dial to about 70 on the BLUE range, tune to maximum deflection on the millimeter (95).

# WAVEMETERS G61-G62

GD13

By means of the "Valve Balance Adjustment" reduce the milliammeter deflection to a minimum.

Once this balanced position has been found, provided the instrument has been switched on for sufficient time for the valves to be properly heated, it need not be repeated for each frequency measurement, it should be checked periodically and must be checked again if valves (3) and (4) are changed.

Wavemeter (Fig. h). The wavemeter circuit consists of two coupling valves (5) and (6) loosely coupled to a tuned circuit (89) (91) (92) which is in turn loosely coupled to the detector valve (7).

The grid of the first coupling valve is inductively coupled to the balanced coupling circuit by means of the grid coil (72).

Resistance-capacity coupling (79) (80) is used between the first and second coupling valves (5) and (6) and choke-capacity (84) (88) coupling between the second coupling valve and the tuned circuit.

The wavemeter tuning circuit consists of an inductance (89) and a dual range condenser (91) (92) designed to give straight line relation between condenser dial reading and frequency. Switch (90) either cuts out condenser (92) or puts it in parallel with condenser (91), the base plate of this switch is quartered in Red and Blue which indicates the calibration curve to be used, the RED covering the LOWER half, and the BLUE HIGHER half of the frequency range.

The wavemeter resonance tuning is indicated by means of a D.C. milliammeter (95) in the anode circuit of the detector valve (7), this valve is used as a lower anode bend detector, with a potentiometer (102) (103) (104) connected across the H.T. supply for cathode bias adjustment.

The position of the milliammeter pointer is controlled by the "R/F input control" which controls the cathode bias.

Protection of milliammeter. An excessive incoming signal will produce a large grid swing on the detector valve causing grid current to flow, which by passing through the grid leak (94) will increase the negative bias and so limit the rectified anode current to the valve.

Terminals (101, 125) are provided on the outside of the wavemeter which allow for a remote indicator to be connected across the 1000 ohms resistance (96) in the anode circuit of the detector valve.

Wavemeter G61. Covers a frequency range 1000 - 2000 kc/s, the wavemeter calibration book however, is calibrated from 0 - 1000 kc/s, all frequencies being reduced by 1000 kc/s., so that when measuring an incoming frequency the "Thousands" of kc/s. are read directly from the setting of the "Thousands Selector" dial and the hundreds, tens and units are read off the calibration curve. Thus, if the incoming frequency is 8,573 kc/s. the "Thousands Selector" dial is set to No. 8 graduation mark ("Thousands Selector" switch on range 4), and from the wavemeter tuning condenser setting the calibration curve gives 573 kc/s. Actually, when the "Thousands Selector" dial is set to No. 8, the 7th harmonic of the 1000 kc/s. crystal is selected, and this gives a heterodyne beat frequency of 1,573 kc/s, when mixed with the incoming signal. The frequency of 1,573 kc/s. is measured by the wavemeter.

The reason for adopting this procedure is that the frequency range from 1000 to 2000 kc/s. can be covered with a single tuning coil whereas from 0 to 1000 kc/s would be impossible in the space available.

The scale of the "Thousands Selector" dial is calibrated directly in integral multiples of 1000 kc/s. and operates in conjunction with the "Thousands Selector Switch".

Thousand Selector Switch	Graduation marks on "Thousand Selector" dial.
Range 2	2 and 3
3	4, 5 and 6
4	7, 8                      14
5	15, 16                    24

Tuning condenser switch (90) RED range calibration extends from 0 to about 550 kc/s and the BLUE from 550 to 1000 kc/s.

Wavemeter G62. Has been designed as an absorption wavemeter covering a frequency range of 15 to 200 kc/s., these ranges are covered by varying the value of the inductance coil (89) by means of a tapping switch which is ganged to and operated by the "Hundreds Selector" switch (32) on positions 1 to 4.

With the "Hundreds Selector" switch on ranges 1 to 4 (i.e. for measuring frequencies between 15-200 kc/s.) the wavemeter functions as an absorption wavemeter. The measured frequency corresponding to the tuning dial is read direct from the appropriate curve (i.e. Red or Blue).

## WAVEMETERS G61-62

The frequency ranges of the wavemeter tuning circuit are :-

Hundreds Selector Switch (32)	Dual Range Switch (90)	Wavemeter frequency Range.
Range 1	Red	15 - 20
1	Blue	20 - 26
2	Red	25 - 40
2	Blue	39 - 54
3	Red	50 - 80
3	Blue	80 - 110
4	Red	90 - 150
4	Blue	150 - 214
5 to 8	Red	100 - 150
5 to 8	Blue	150 - 200

On ranges 5 to 8 (i.e. for measuring frequencies between 200 and 2,500 kc/s.) the wavemeter functions as an absorption wavemeter on which the heterodyne beat frequency due to the interaction of the incoming unknown frequency and a locally generated frequency of 100 kc/s. or its integral multiples, is measured.

As is the case with G61, the hundreds of kc/s. are read directly from the setting of the "Hundreds Selector" dial, and the tens and units are read from the calibration curve.

The scale of the "Hundreds Selector" dial is calibrated directly in integral multiples of 100 kc/s. and operates in conjunction with the "Hundreds Selector" switch. The various ranges of the switch have the following graduation marks on the dial :-

Hundreds Selector Switch.		Graduation marks on "Hundreds Selector" Dial.
Range Position.	Kc/s.	
1	15 - 25	Not used
2	25 - 50	" "
3	50 - 100	" "
4	100 - 200	" "
5	200 - 400	2, 3.
6	400 - 700	4, 5, 6.
7	700 - 1400	7, 8..... 12, 13.
8	1400 - 2500	14,15..... 29, 30.

Power Supplies. The normal power supplies for operating wavemeters G61 - G62 are :-

- (a) 210 volts D.C. and 230 volts, 50 cycles A.C. when using an Admiralty Pattern oven.
- (b) 12 volts A.C./D.C. when using an Army type oven.

When using the Admiralty Pattern oven 230 volts A.C. is supplied to the terminals (26) of the oven, also to the transformer (105) which supplies the 6 volts required for the valve heater circuit. The above supplies are fed via a 1204B rectifier unit switch, terminals (128) (129) marked "230 volts A.C." and the safety contacts (123).

The 210 volts D.C. supply required to supply the anode current for the valves is obtained from the 1204B rectifier unit to terminals (126) (127) via safety contacts (124).

The A.C. supply to the oven is a separate supply and is left on in order to keep the oven at its correct working temperature, but the 230 volts A.C. to the transformer (105) and the 210 volts D.C. are controlled by a switch on the rectifier unit, and only required to be switched on about one minute before using the wavemeter to allow the valves to be properly heated.

Where an Army type oven is used a 12 volt A.C./D.C. supply is employed to heat the oven via terminals (111) (112) and single pole switch (118), and to the valve heater circuit via contact pins and socket contacts (25) through a 3.3 ohms voltage reducing resistance (122) (to reduce the supply to the valve filament to 6 volts), and valve heater "ON-OFF" switch (121). If 12 volts A.C. is used, an external transformer is employed with an 8 mfd. condenser across terminals (112) (113).

# WAVEMETERS G61-62

GD15

Admiralty Pattern 3190 oven. (Fig. d and e). The oven (24) is heated by a number of resistance mats (23) disposed round the inner walls and are fed from a 230 volts, 50 cycle supply. The thermostat contacts (22) are used to short-circuit a high resistance (21) fitted at the back of and outside the oven, when this resistance is short circuited the heating current is in the order of 150 milliamps, but when the thermostat operates and brings this resistance in the circuit the heating current falls to about 3 milliamps the thermostat control is adjusted to give an oven temperature of approximately 50°C.

Adjustment of the oven temperature may be necessary owing to change of the ambient temperature, this can be effected by removing coverplate (108) which discloses a plug of insulating material, beneath this plug is a screw (109), which when rotated in a clockwise direction increases the operating temperature and vice versa. With an oven temperature of 50°C, the temperature variations within the crystal holder (110) are less than  $\pm 0.25^\circ\text{C}$ .

## ADMIRALTY PATTERN 3190 OVEN

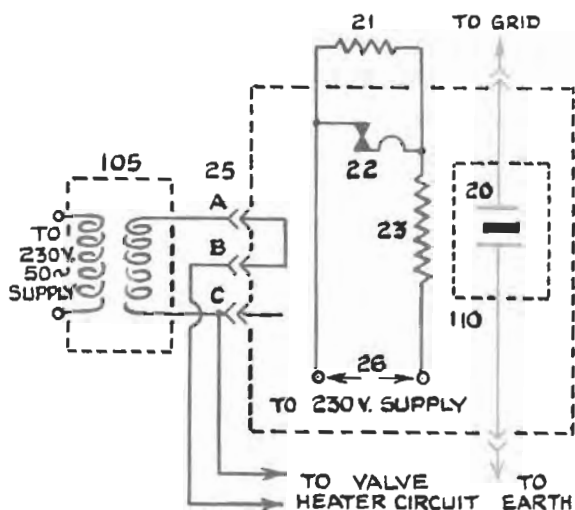

FIG. d

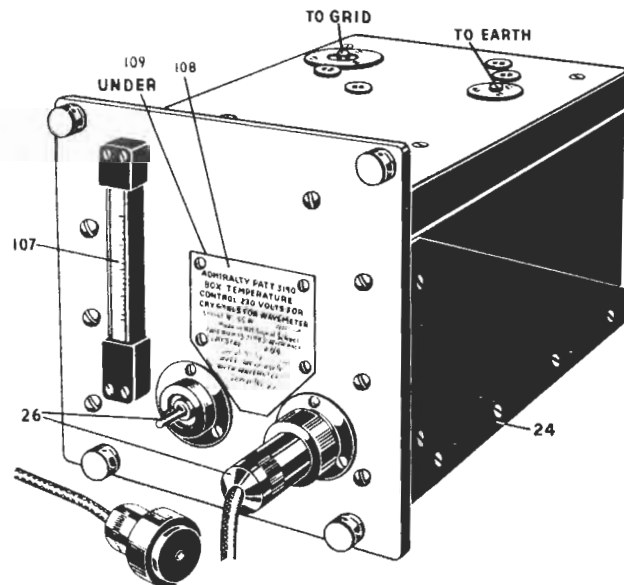

FIG. e.



Army type oven (Fig. f and g). The oven is similar in construction and operation to the Admiralty type, except that 12 volts A.C. or D.C. is used and the adjustment is made in a similar manner by means of screw (115), locking screw (117) and setting dial (116) marked '0 - 8' which give a variation of heating current from 2.85 amps to 3.5 amps.

The heating current is controlled by switch (118), a 12 volt lamp (119) which is visible through a red glass panel on the front, indicates that current is passing through the heating resistance via the thermostat contacts (22). The thermostat begins to "make" and "break" causing the lamp to go "ON" and "OFF" when the oven temperature reaches about 40°C. The temperature becomes steady after about two and a half hours.

### ARMY TYPE OVEN

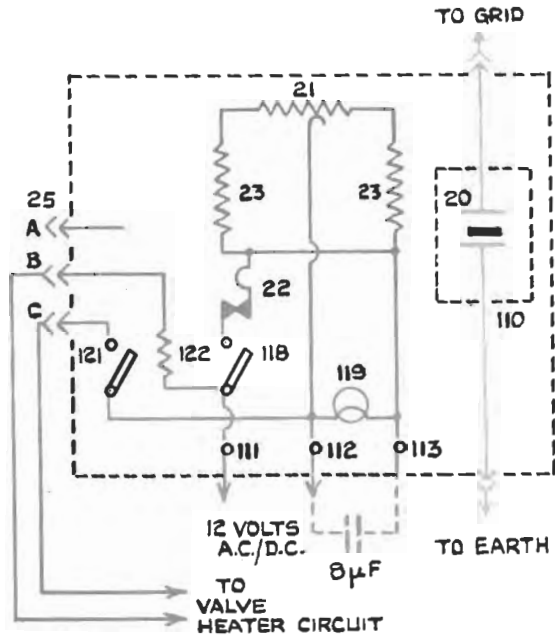

FIG. f

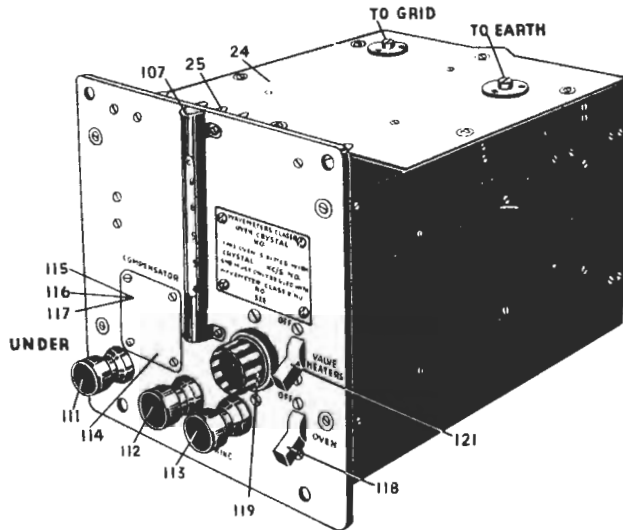

FIG. g.

# WAVEMETERS G61- G62

## INTERPOLATING ABSORPTION WAVEMETER

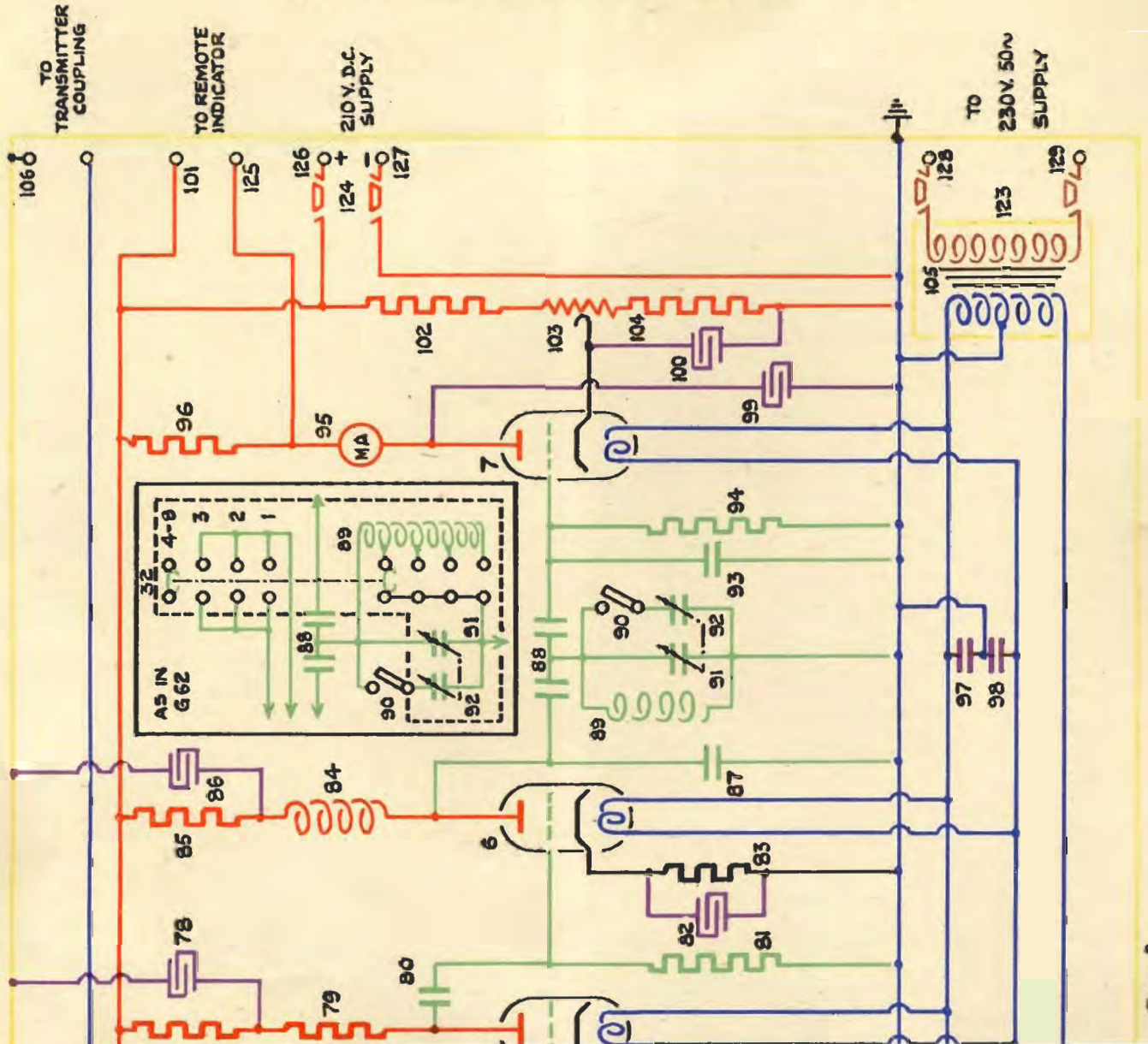
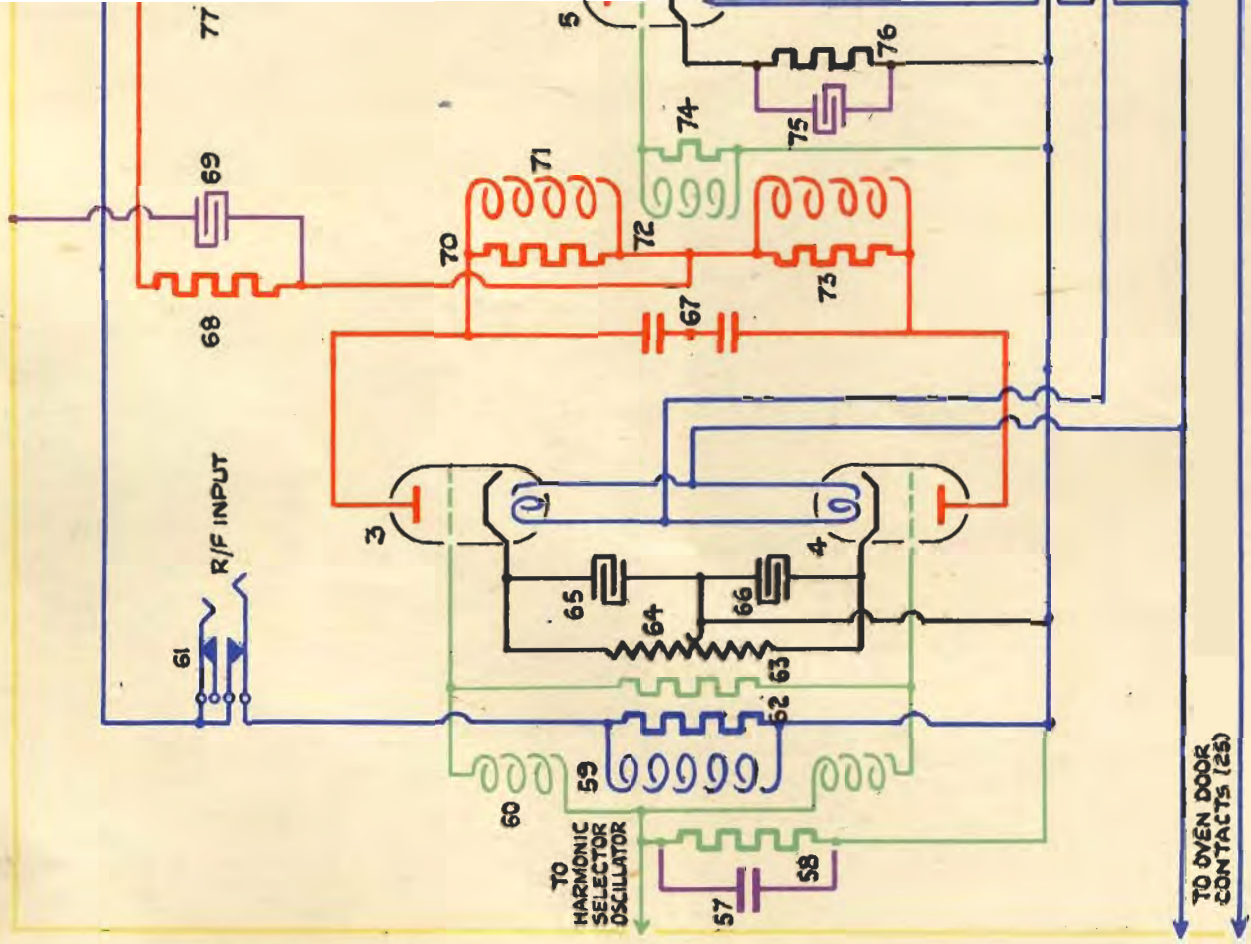

Fig. 8



Operation. The operating of both G61 and G62 is almost identical so for this purpose we will deal with one wavemeter only (G62).

To Measure an unknown frequency between 15 and 2,500 kc/s. Set the "Hundreds Selector" range switch (32) to Range 1 - 4 and with the "R/F Input Control" resistance (103) set to give a millimeter deflection of about 0.1 mA., go slowly through the whole range of the "Wavemeter Tuning" condenser (91) (92) (with the RED and BLUE curve switch (90) in each position in turn), beginning at 0 in the RED position and working upwards to about 70 in the BLUE position, searching for a vigorous deflection on the millimeter (95). If such a deflection is obtained, tune in carefully to the maximum deflection and read off the frequency from either the RED or BLUE calibration curve according to the position of the switch.

NOTE :- With the "Hundreds Selector" switch (32) in position 1 - 4, the "Harmonic Selector" oscillator does not function and the wavemeter simply operates similarly to Wavemeter G56 and G57.

If no vigorous deflection of the millimeter is obtained on Range 1 - 4, switch to Range 5, set the "Hundreds Selector" dial (34) to No. 2 graduation mark. The graduation marks 2, 3, etc., only serve as a guide and accurate adjustment of the heterodyne selector oscillator to the particular harmonic must be made by listening for dead space. Search through the whole of the Red and Blue ranges as before with the Wavemeter Tuning condenser for vigorous deflection of the millimeter.

On this range small spurious deflections may occur at the settings of the absorption wavemeter for 0 and 100 kc/s. but with proper balancing of the "Valve Balancing Adjustment" (64) these spurious deflections can be made small, while correct tuning gives a vigorous and unmistakable deflection.

If no such deflection is found with the "Hundreds Selector" dial at No. 2 graduation mark, turn it to No. 3 graduation mark and search again with the Wavemeter Tuning condenser. If still no vigorous deflection of the millimeter is found, switch the "Hundreds Selector" switch to position 6 and set the "Hundreds Selector" dial to No. 4 graduation mark, searching again with the wavemeter tuning condenser. Continue this procedure until a vigorous deflection of the millimeter is found.

When a vigorous deflection is obtained, tune carefully by the Wavemeter Tuning condenser (91) (92) till the deflection is a maximum and then read off the corresponding frequency from the RED or BLUE curve (according to the position of the switch (90) ) in the calibration book. Add the frequency reading to the hundreds figure given by the "Hundreds Selector" dial graduation mark and the result is the frequency being measured.

The grid coil (60) of the coupling circuit is connected to the harmonic selector oscillator from its centre tap and the signal it is desired to measure is coupled mutually to the grid coil by coil (59). This coil is energised either from the "To Transmitter Coupling" terminal (106) or from a local oscillator (G35) by connecting a plug into the jack (61) marked "R/F Input". This jack disconnects the transmitter coupling terminal from coil (59).

To Set a Transmitter to a Required Frequency. Set the "Hundreds Selector" switch (32), the "Hundreds Selector" dial (34), the "Wavemeter Tuning" condenser (91) (92) and the RED and BLUE curve switch (90) to give the required frequency from the calibration book.

Adjust the "R/F Input Control" resistance (103) to give a millimeter deflection of about 0.1 mA and tune the transmitter to give a vigorous deflection on the millimeter, starting with the transmitter at a higher frequency than that required and work down in frequency until the deflection is found. The reason for this is apparent from the following example :-

Suppose it is required to set a transmitter to 530 kc/s. Set the "Hundreds Selector" switch (32) to 5, the "Hundreds Selector" dial to No. 5 graduation mark, the "Wavemeter Tuning" condenser (91) (92) and Red and Blue curve switch (99) to give a frequency of 30 kc/s. from the calibration book, i.e. the "Harmonic Selector" oscillator is at 400 kc/s and the absorption wavemeter at 130 kc/s.

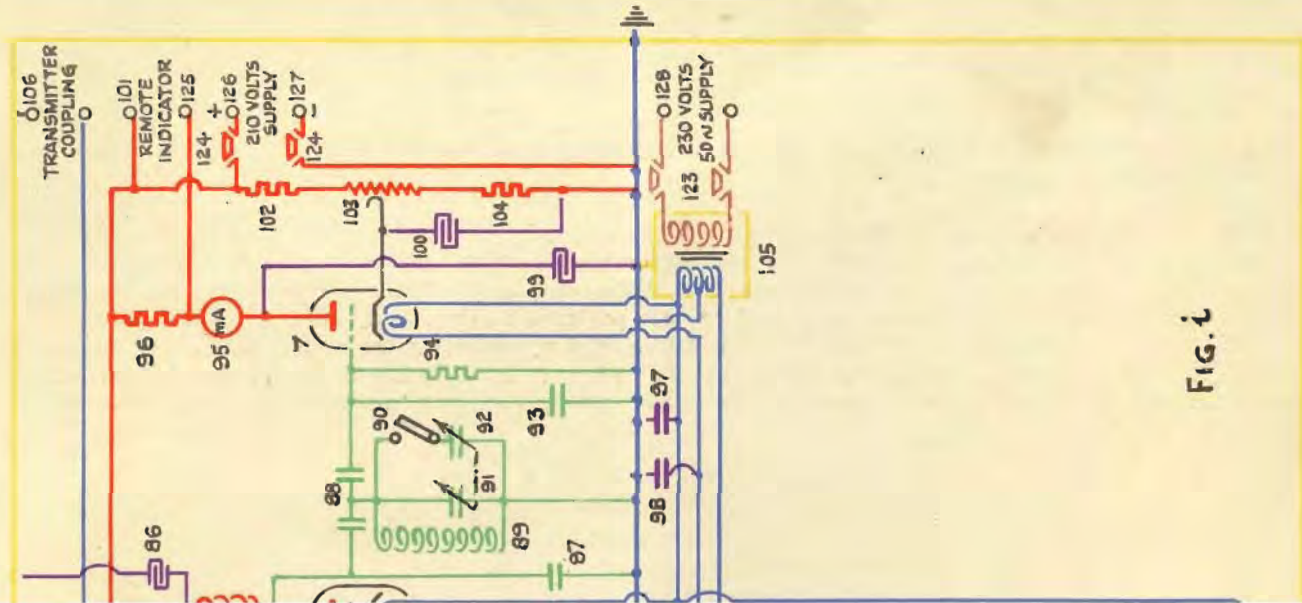
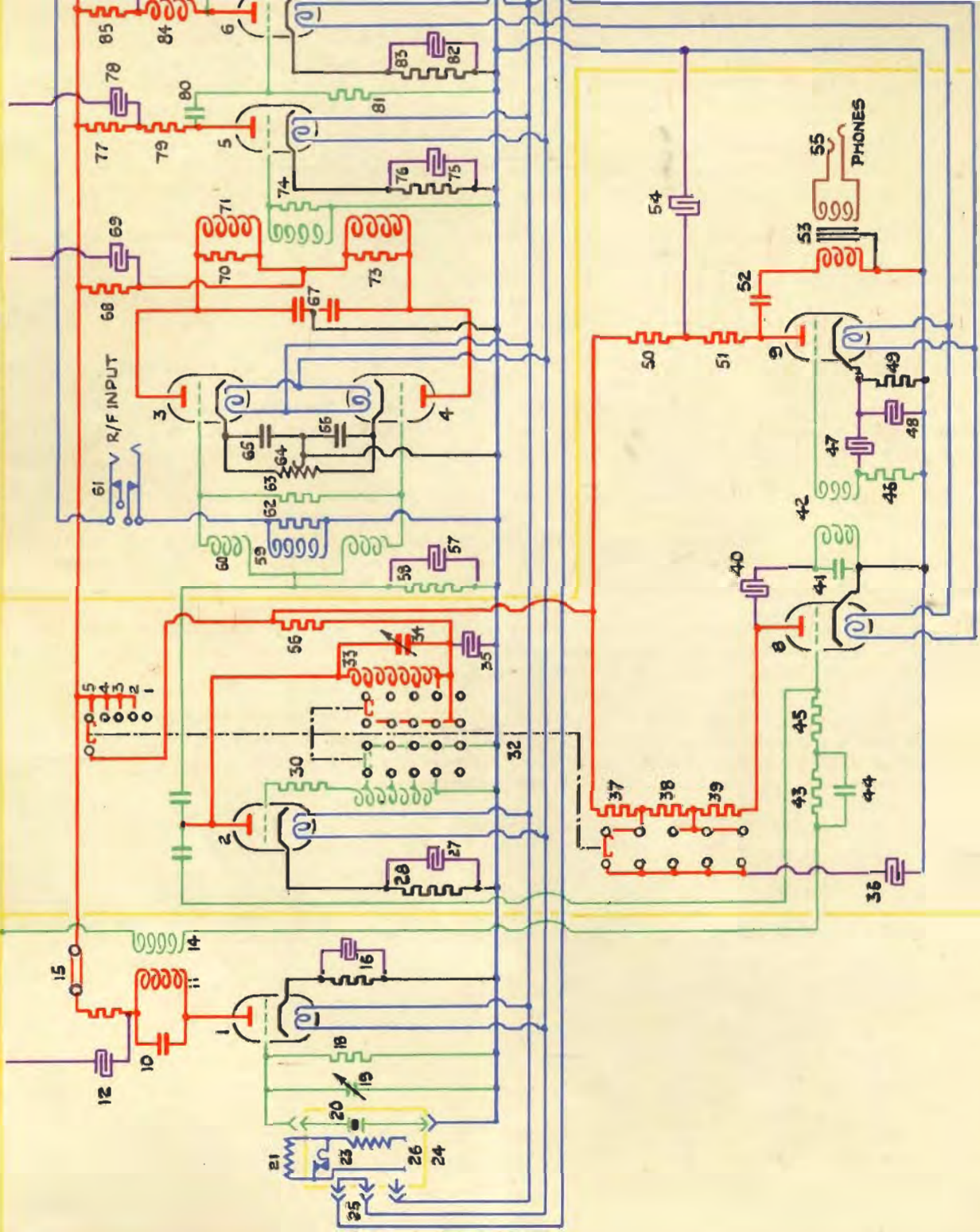

FIG. 1

# WAVEMETER G6I



# WAVEMETERS G61-G62

GD19

**Double Readings.** Since the function of the absorption wavemeter on ranges 5 to 8 is merely to measure a frequency difference between the selected multiple of 100 kc/s. and the incoming frequency a wavemeter reading can be obtained for two different settings of the "Hundreds Selector" dial (34). One reading when the frequency to be measured exceeds the frequency of the selected multiple of 100 kc/s., and the other when the frequency of the selected multiple of 100 kc/s. exceeds that of the frequency to be measured, e.g., if the frequency to be measured is 530 kc/s., one wavemeter reading will be obtained with the "Hundreds Selector" dial at No. 5 graduation mark and the "Wavemeter Tuning" condenser at about 66.2° (30 kc/s. on the RED curve from the calibration book). A second wavemeter reading will be obtained with the "Hundreds Selector" dial at No. 8 graduation mark and the "Wavemeter Tuning" condenser at about 35.1° (70 kc/s. on the BLUE curve from the calibration book), thus apparently giving a frequency of 870 kc/s. The explanation of this apparent discrepancy is as follows :-

- (i) With the "Hundreds Selector" dial (34) at No. 5 graduation mark, the harmonic actually selected is 400 kc/s. and the wavemeter measures the beat frequency of 130 kc/s., giving a resultant frequency of 530 kc/s.
- (ii) With the "Hundreds Selector" dial (34) at No. 8 graduation mark, the harmonic actually selected is 700 kc/s. and the wavemeter measures the beat frequency of 170 kc/s. This gives a reading of 870 kc/s. which is false.

As there is, in practice, no means of knowing this when measuring the unknown frequency, it is important to begin with the lowest frequency settings and search for a deflection on the milliammeter by working up in frequency, i.e. from 200 kc/s. towards 2,500 kc/s. A transmitter frequency however is roughly known and it is possible to set the "Hundreds Selector" dial on the correct hundreds figure and search once with the "Wavemeter Tuning" condenser. (e.g.)

Transmitter Frequency	Hundred Selector	Beat Frequency	Wavemeter Measurement	Indicator Reading	Remarks
700	400	300	130	Nil	
600	400	200	130	Small	
530	400	130	130	Max.	True Deflection
500	400	100	130	Small	
400	400	0	130	Nil	
300	400	100	130	Small	
270	400	130	130	Max.	False Deflection
200	400	200	130	Small	

The fact that two different wavemeter readings can be obtained with a single incoming frequency may be used to check the accuracy of the wavemeter calibration curves. The sum of the respective readings from the calibration book should be exactly 100 kc/s. If the latter is not the case either the procedure of measurement has not been carried out correctly or there is an error in the calibration curves, the latter, however, can be corrected without much difficulty, since the calibration of each wavemeter is carried out from its own crystal oscillator.

**Accuracy.** The accuracy of frequency measurement possible with Wavemeter G62 is limited to practical tolerances in its components to  $\pm 0.1$  kc/s. over the whole frequency range. To obtain this accuracy care must be taken to keep the "Hundreds Selector" dial (34) within the dead space of the heterodyne note while the Wavemeter Tuning condenser (91) (92) is adjusted to the maximum millimeter deflection.

The components of the tuned circuit of the wavemeter have been selected to have low temperature co-efficients of inductance or capacity, so that very large changes of temperature would be required to produce an error of the order of 1 part in 1,000. Any error due to changes in the components of the wavemeter may be corrected since the interpolating absorption wavemeter is calibrated directly from the crystal harmonics. Calibration of Interpolating Absorption Wavemeter. The method of calibration of the Interpolating Absorption Wavemeter is carried out as follows:-

- (i) Turn the pointer of the "Valve Balance Adjustment" (64) to its maximum in either the clockwise or anticlockwise direction. This will allow energy to pass directly from the harmonic selector circuit into the interpolating absorption wavemeter.
- (ii) Set the "Hundreds Selector" (G62) "Thousand Selector" (G61) switch (32), to position 2 and the "Hundreds Selector" (G62) "Thousands Selector" (G61) condenser dial (34) to No. 2 graduation mark.  
NOTE:- The crystal fundamental of 100 kc/s (G62), 1000 kc/s G61, is now selected.
- (iii) Set the "R/F Input Control" resistance (103) to a suitable adjustment. A maximum deflection on the millimeter will not be obtained with the "Wavemeter Tuning" condenser at the setting corresponding to 0 kc/s on the RED calibration curve with the switch (90) in the RED position.
- (iv) Turn the "Hundreds Selector" (G62) "Thousands Selector" (G61) dial (34) from No. 2 graduation mark towards No. 3 graduation mark and a large number of subsidiary harmonics can be picked out by means of the heterodyne "squeals" heard in the telephones. For each of these subsidiary harmonics (carefully tuned to the dead space) a point on the wavemeter calibration curve can be obtained by adjusting the wavemeter Tuning Condenser to get a maximum deflection on the millimeter. Some of the subsidiary harmonics are very much louder than others, i.e. those obtained by dividing 100 (G62) 1000 (G61) by the numbers 2, 3, 4 and 5 are the louder, therefore easier to distinguish. The calibration "curve" is so nearly a straight line that a ruler can be used to draw the line connecting points, except for the portion of the RED curve beyond 90 divisions of the scale of the wavemeter condenser.



GD20

# WAVEMETERS G61 - G62

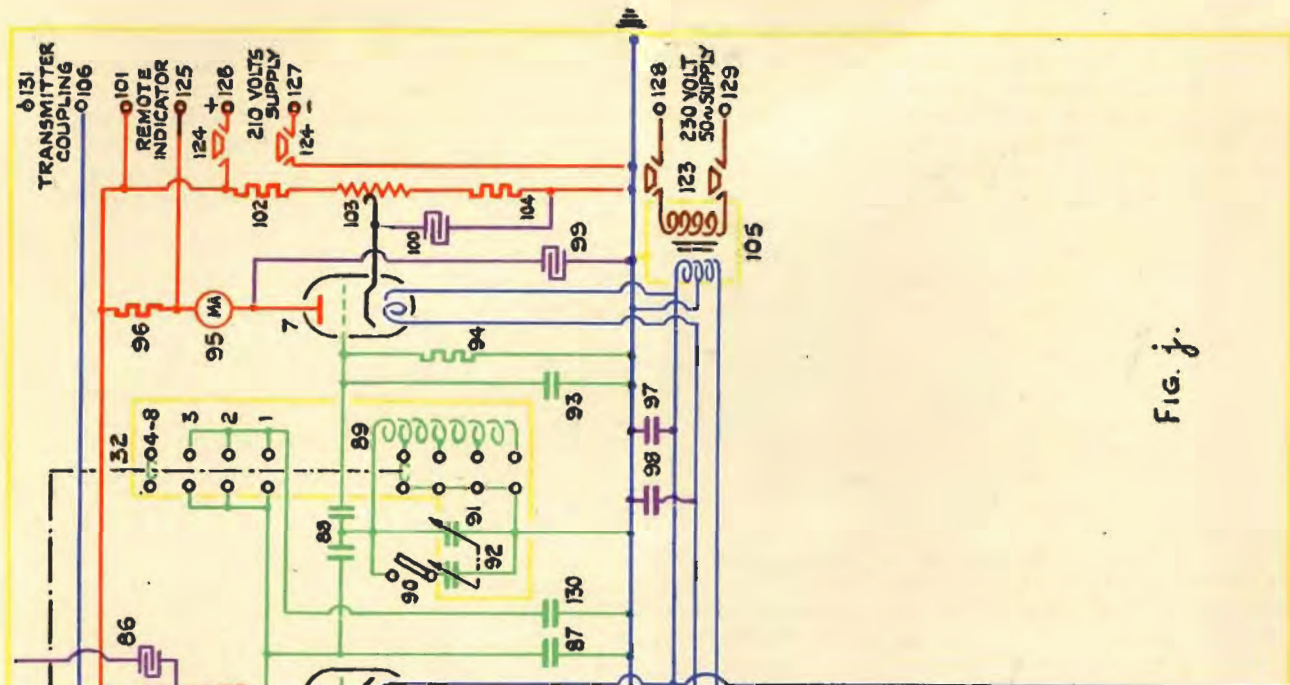

FIG. j.

# WAVEMETER G62

