

DIAGRAMMATIC SKETCH OF TRANSMITTING AND RECEIVING GEAR.

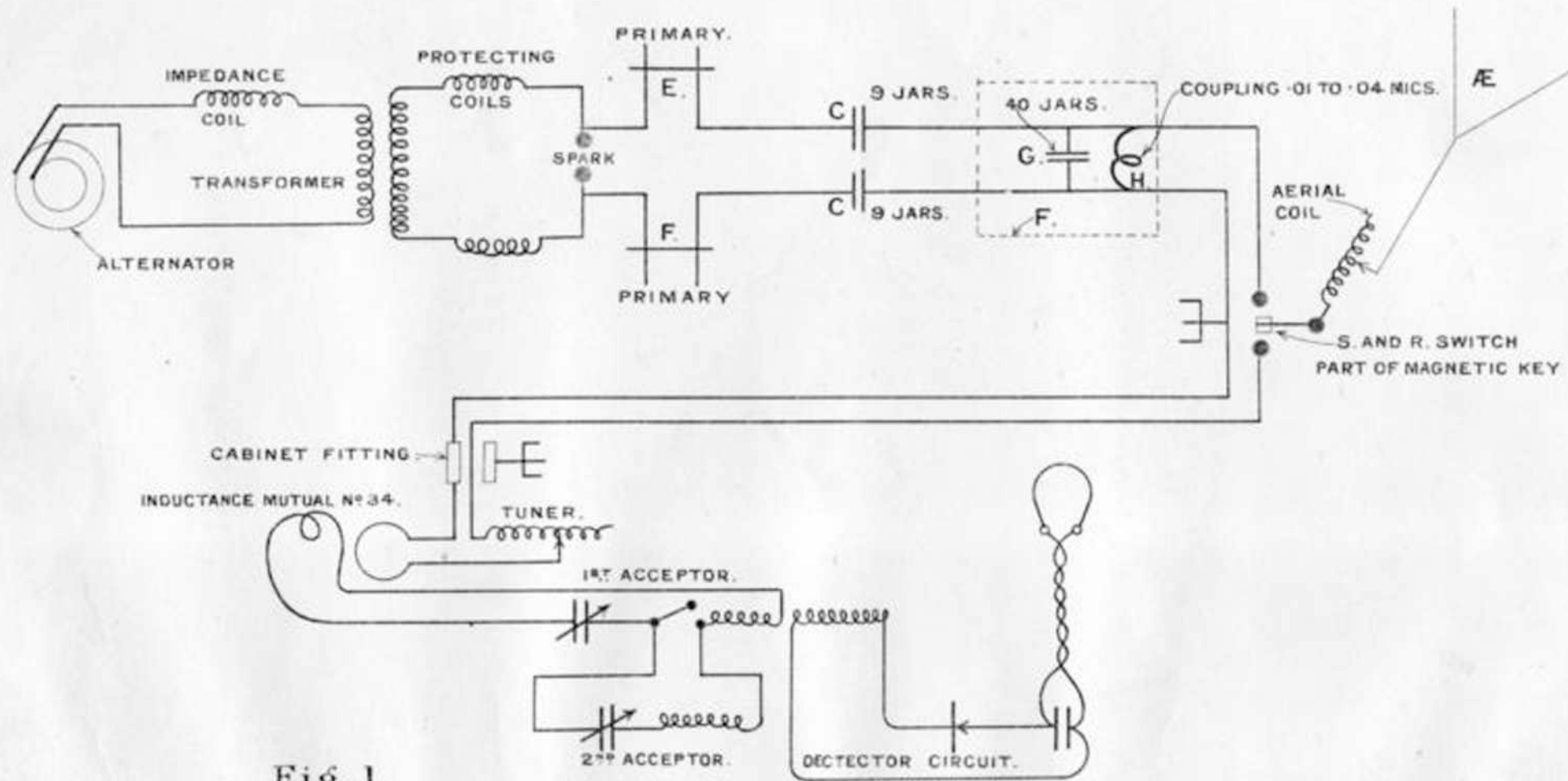

Fig. 1.

750 8/14

H. K. C. GRAMMAY LTD. LITTON, LONDON, S.E.

DIAGRAM OF A. C. LEADS AND D. C. MOTOR LEADS.

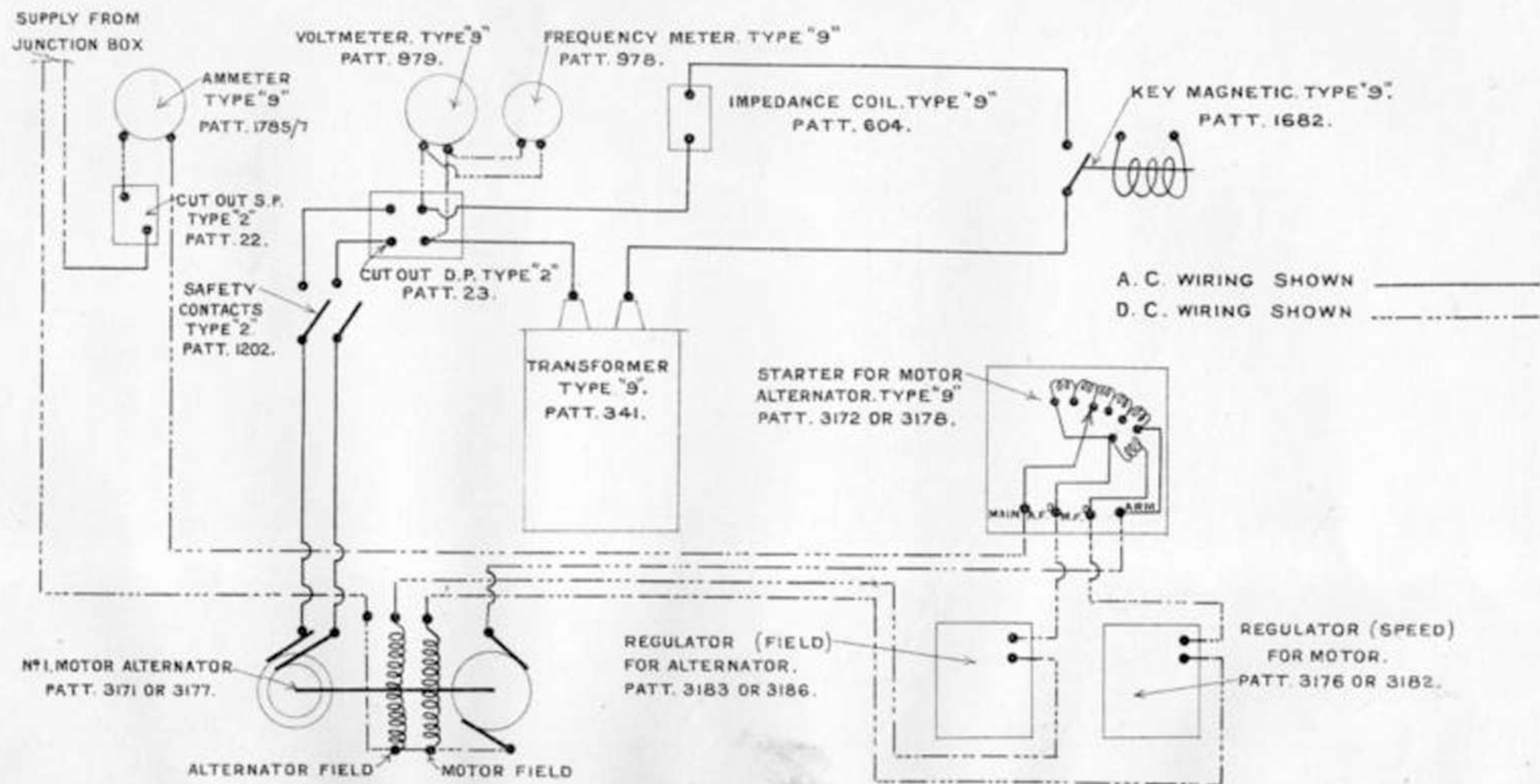

Fig. 11.

OPERATING CIRCUIT.

(DIAGRAMMATIC.)

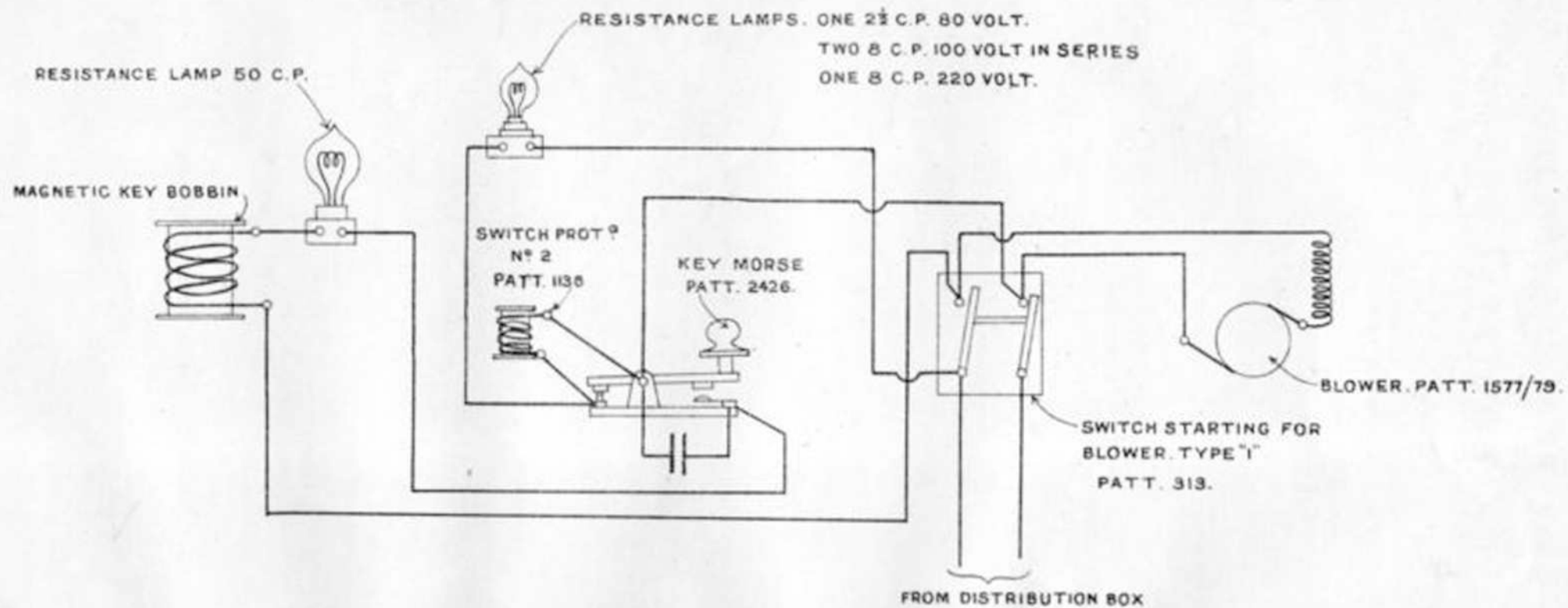
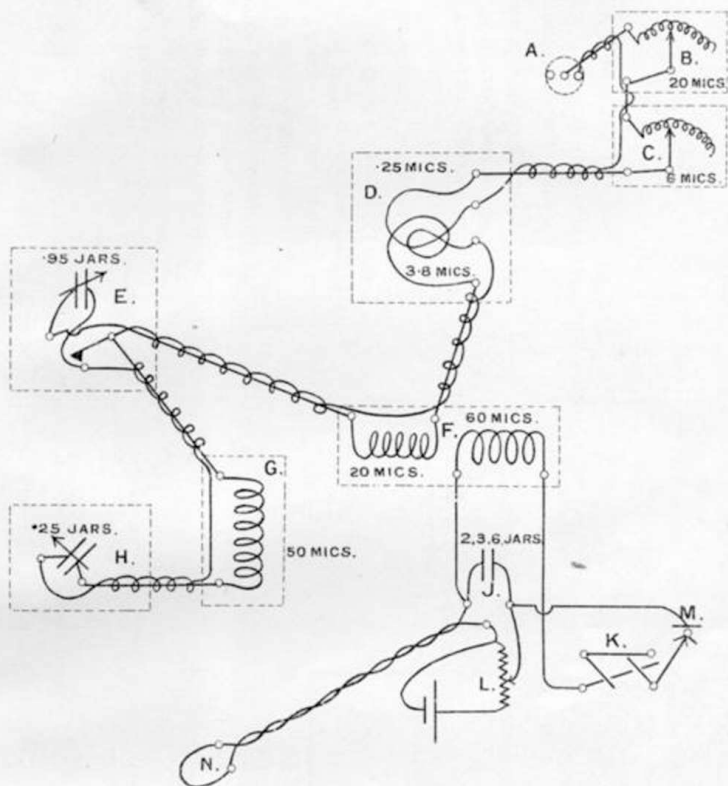

Fig. 13.

RECEIVING CONNECTIONS.

(DIAGRAMMATIC.)



REFERENCE TABLE

A. CABINET FITTING.	H. CONDENSER. N° 12.
B. INDUCTANCE AERIAL N° 3.	J. TELEPHONE CONDENSER.
C. INDUCTANCE ADJUSTABLE. N° 13.	K. PROTECTING SWITCH. N° 2.
D. INDUCTANCE MUTUAL. N° 34.	L. POTENTIOMETER.
E. CONDENSER N° 7.	M. DETECTOR.
F. INDUCTANCE MUTUAL. N° 33.	N. "Q" TYPE TELEPHONES.
G. INDUCTANCE FIXED N° 22.	

Fig. 14.

5

Copy 1

N-11

1-410

Letm No S.S. 4.

OU ~~5554~~

HANDBOOK

FOR

CRUISER AUXILIARY W/T SET
(TYPE 9).

1914.

TECHNICAL LIBRARY.

✓ 5

SIGNAL SCHOOL, PORTSMOUTH.

SECTION THRO' SPARK GAP.

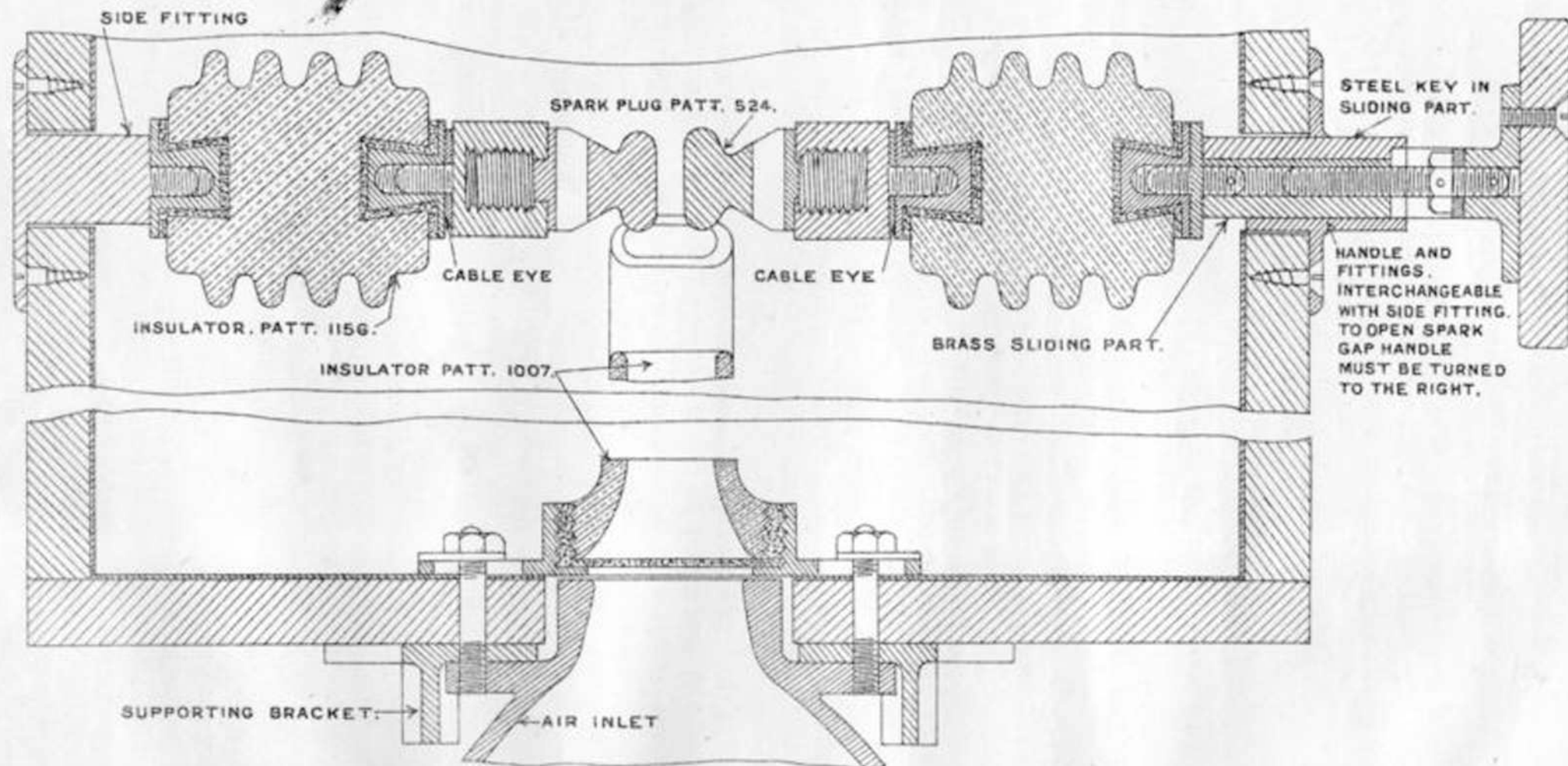

Fig. 4.

MAGNETIC KEY AND SEND-RECEIVE SWITCH.

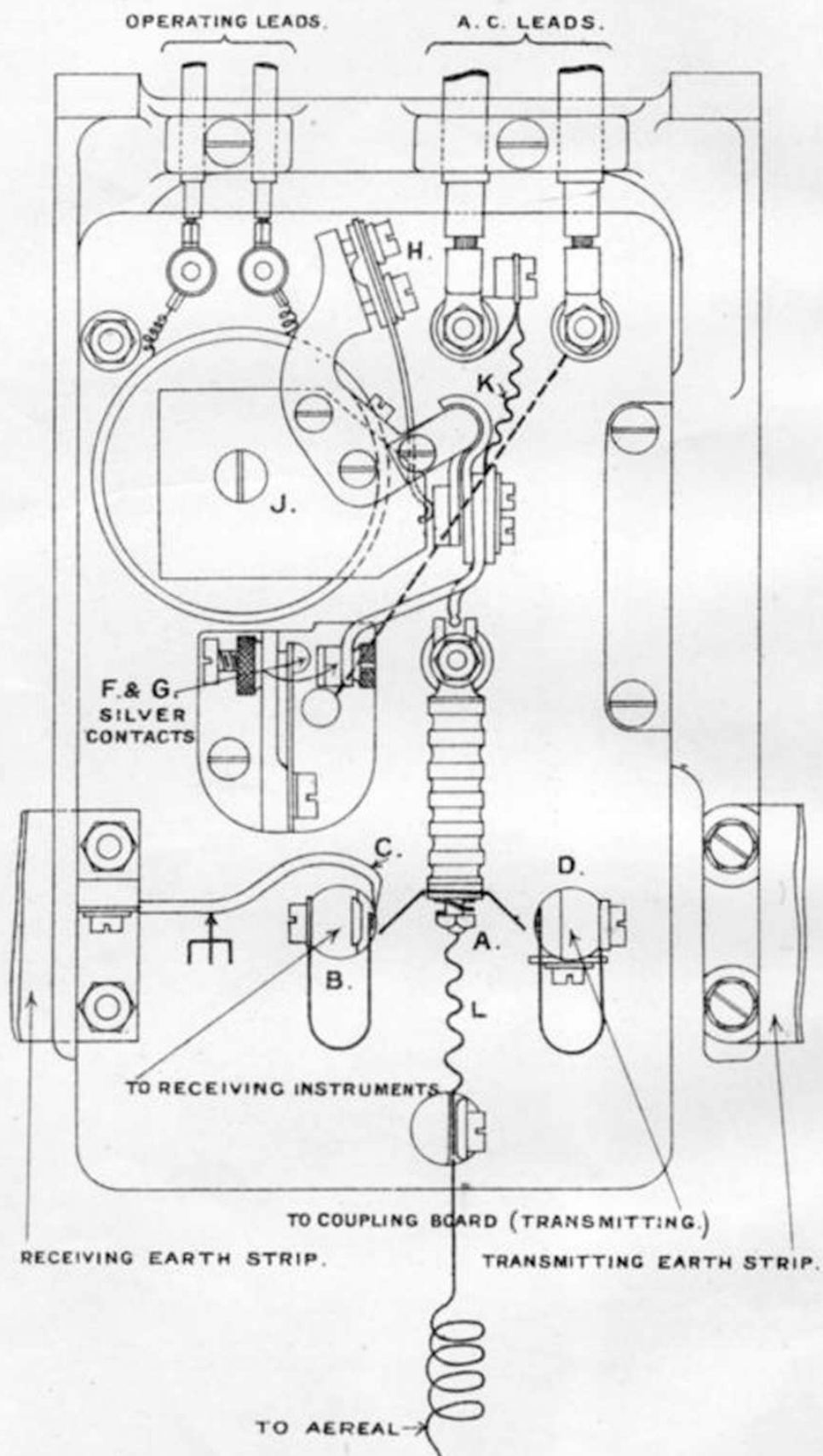
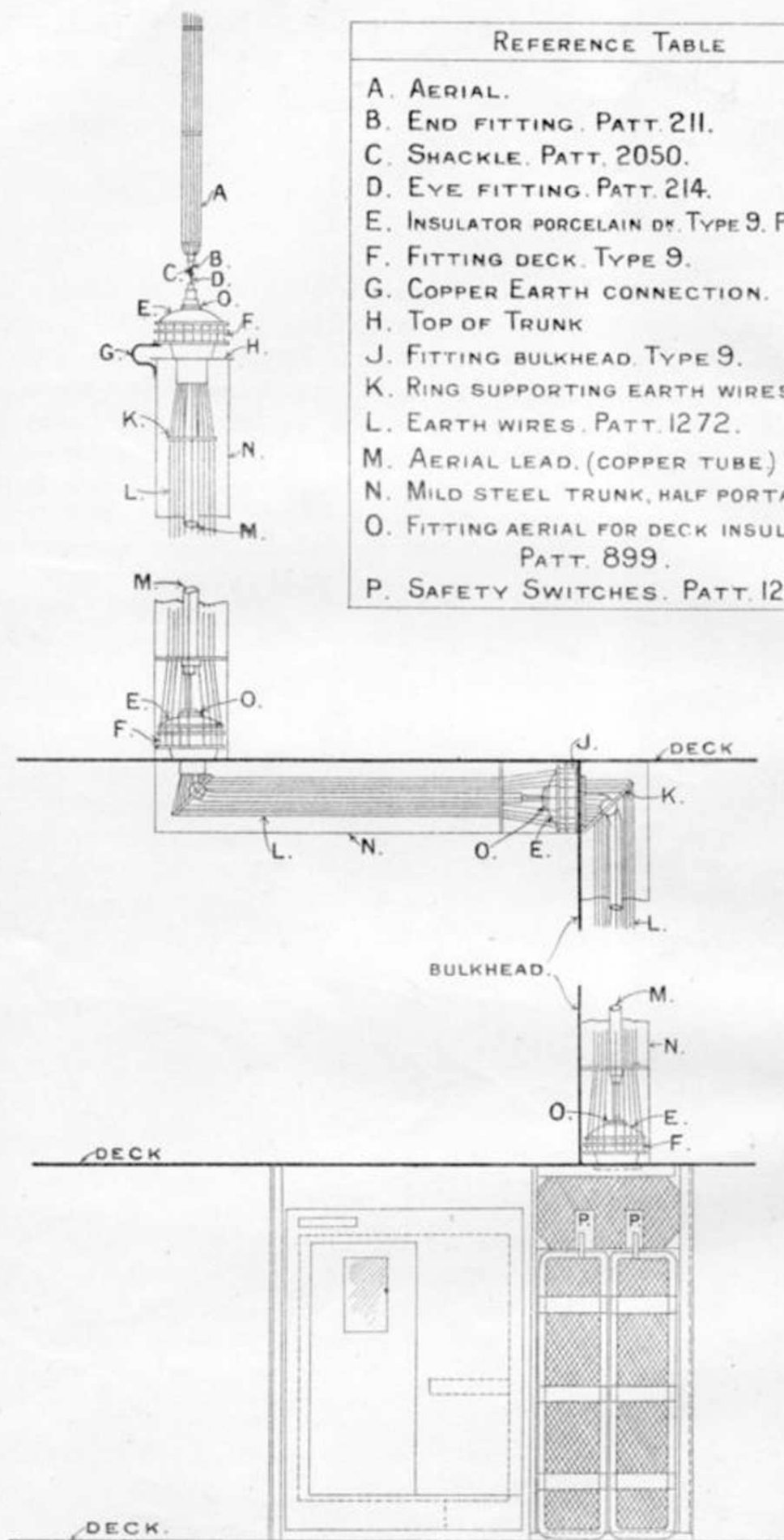

Fig. 6.

TYPICAL AERIAL TRUNK.



REFERENCE TABLE

- A. AERIAL.
- B. END FITTING. PATT. 211.
- C. SHACKLE. PATT. 2050.
- D. EYE FITTING. PATT. 214.
- E. INSULATOR PORCELAIN DR. TYPE 9. PATT. 962.
- F. FITTING DECK. TYPE 9.
- G. COPPER EARTH CONNECTION.
- H. TOP OF TRUNK
- J. FITTING BULKHEAD. TYPE 9.
- K. RING SUPPORTING EARTH WIRES.
- L. EARTH WIRES. PATT. 1272.
- M. AERIAL LEAD. (COPPER TUBE)
- N. MILD STEEL TRUNK, HALF PORTABLE.
- O. FITTING AERIAL FOR DECK INSULATOR PATT. 899.
- P. SAFETY SWITCHES. PATT. 1202.

Fig. 7.

REFERENCE TABLE.

Fig. 8.

- A.—Aerial lead (copper tube).
- B.—Ebonite tube pinned to aerial lead.
- C.—Fitting aerial for deck insulator, pattern 899.
- D.—Copper flexibles lashed to aerial lead and to fitting in deck insulator.
- E.—Felt packing enclosed in lead foil.
- F.—Insulator porcelain for deck, type 9, pattern 962.
- G.—Deck fitting, pattern 897.
- H.—Earth wires, pattern 1,272.
- J.—Copper tube on deck fitting.
- K.—Copper flexible connecting aerial lead to coil.
- L.—End piece (supplied with aerial coil).
- M.—Coil aerial, type 9, pattern 1,705.
- N.—Magnetic key, type 9, pattern 1,682.
- O.—Pitch.

LOWER END OF AERIAL TRUNK AND AERIAL COIL.

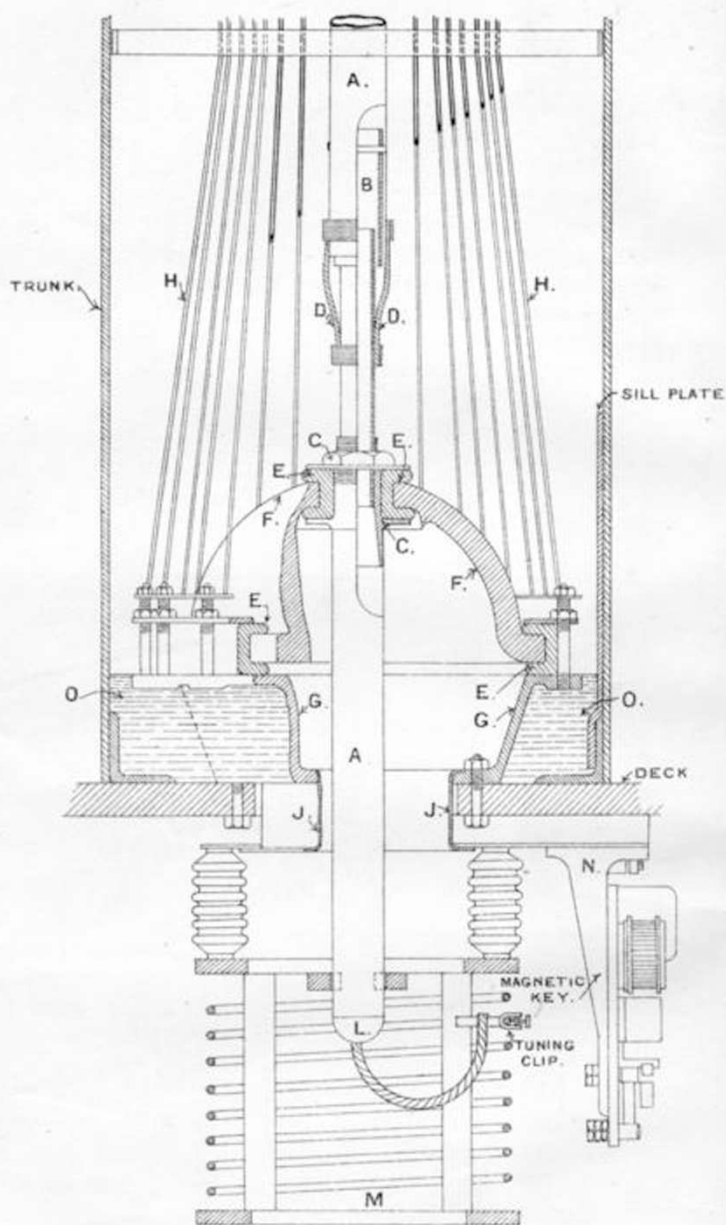
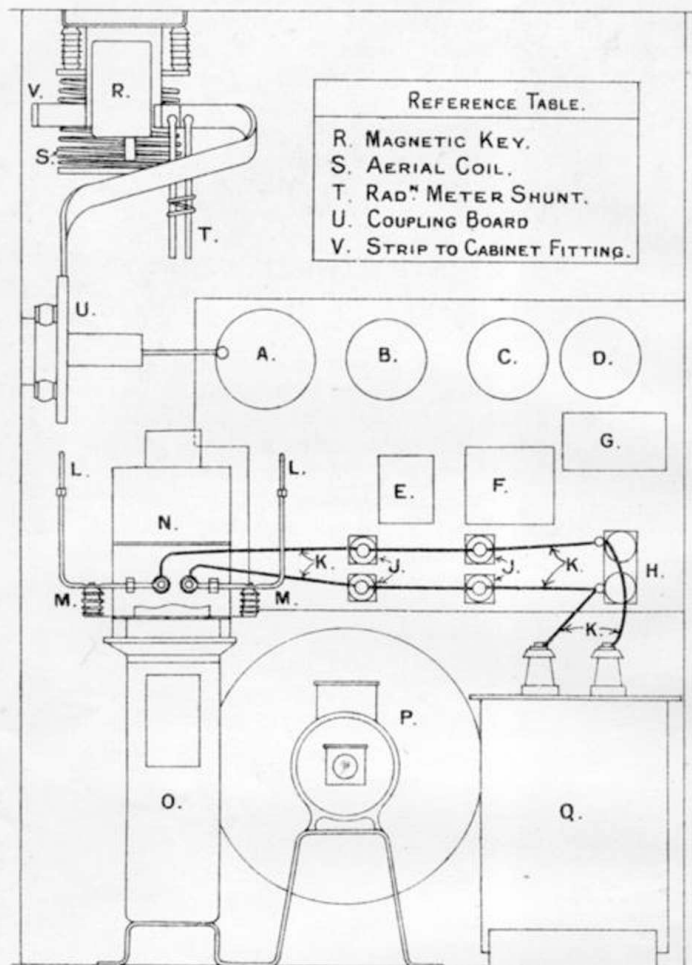

Fig. 8.

ARRANGEMENT OF INSTRUMENTS IN CAGE.

LEFT HAND ARRANGEMENT.



REFERENCE TABLE.	
R.	MAGNETIC KEY.
S.	AERIAL COIL.
T.	RAD ^m METER SHUNT.
U.	COUPLING BOARD
V.	STRIP TO CABINET FITTING.

REFERENCE TABLE.

A.	RADATION METER.	J.	INSULATORS PATT. 465.*
B.	AMMETER.	K.	H.T. TRANSFORMER LEADS.*
C.	VOLTMETER.	L.	PRIMARY FITTINGS *
D.	FREQUENCY METER.	M.	INSULATORS PATT. 1156. *
E.	SINGLE POLE CUT OUT.	N.	SPARK GAP.
F.	DOUBLE POLE CUT OUT.	O.	CONDENSER.
G.	IMPEDANCE COIL.	P.	BLOWER.
H.	PROTECTING COILS.	Q.	TRANSFORMER.

* To be fitted by SHIPS STAFF.

Fig. 9.

ARRANGEMENT OF INSTRUMENTS IN CAGE.

RIGHT HAND ARRANGEMENT.

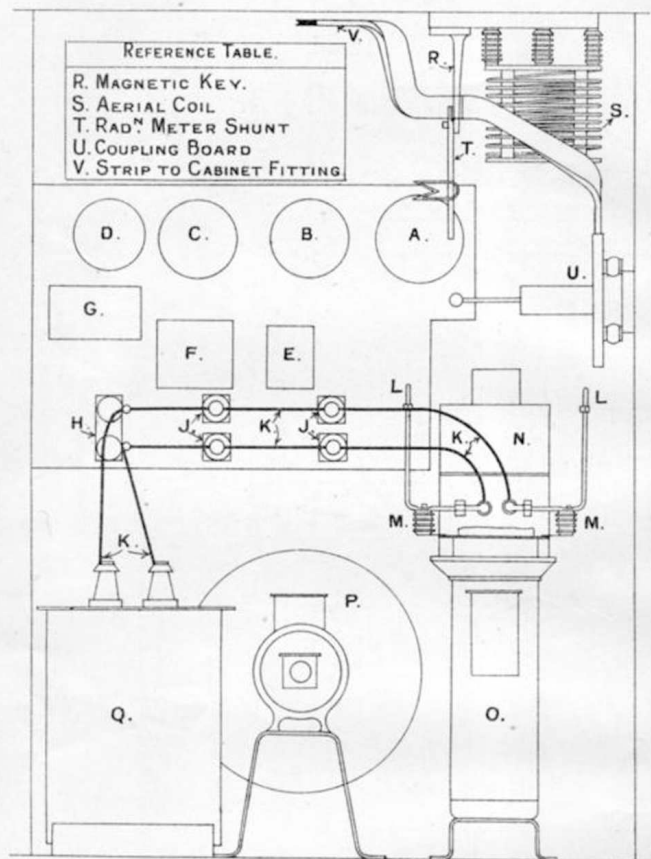

REFERENCE TABLE.

A. RADIATION METER.	J. INSULATORS. PATT. 465. *
B. AMMETER.	K. H.T. TRANSFORMER LEADS. *
C. VOLTMETER.	L. PRIMARY FITTINGS. *
D. FREQUENCY METER.	M. INSULATORS. PATT. 1156. *
E. SINGLE POLE CUT OUT.	N. SPARK GAP.
F. DOUBLE POLE CUT OUT.	O. CONDENSER.
G. IMPEDANCE COIL.	P. BLOWER.
H. PROTECTING COILS.	Q. TRANSFORMER

* TO BE FITTED BY SHIPS STAFF.

Fig.10.

TOP OF CONDENSER TANK AND PRIMARY FITTINGS

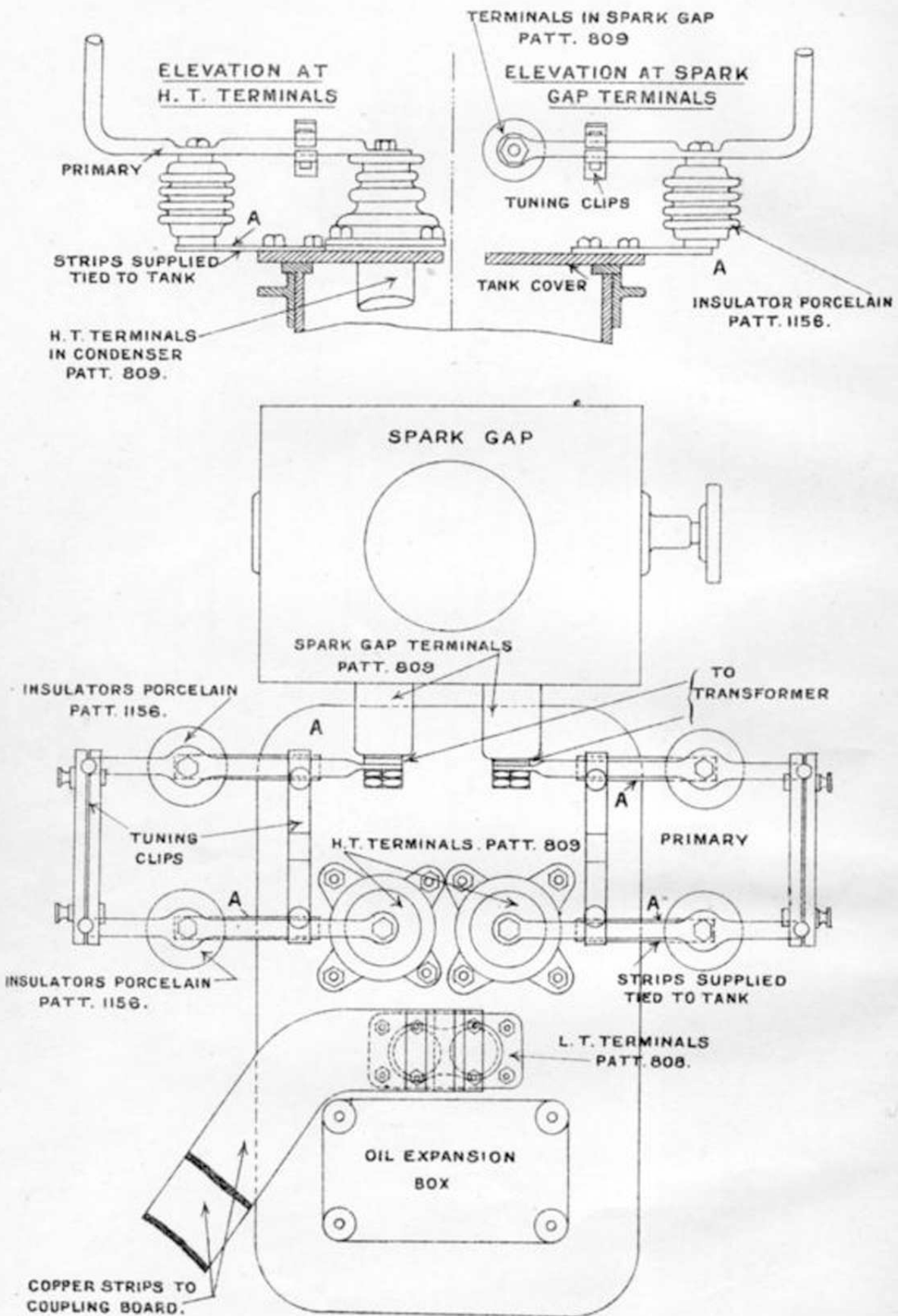

Fig. 12.

ARRANGEMENT OF RECEIVING INSTRUMENTS.

WITH RESPECT TO POSITION OF WINDOW AND CABINET FITTING.

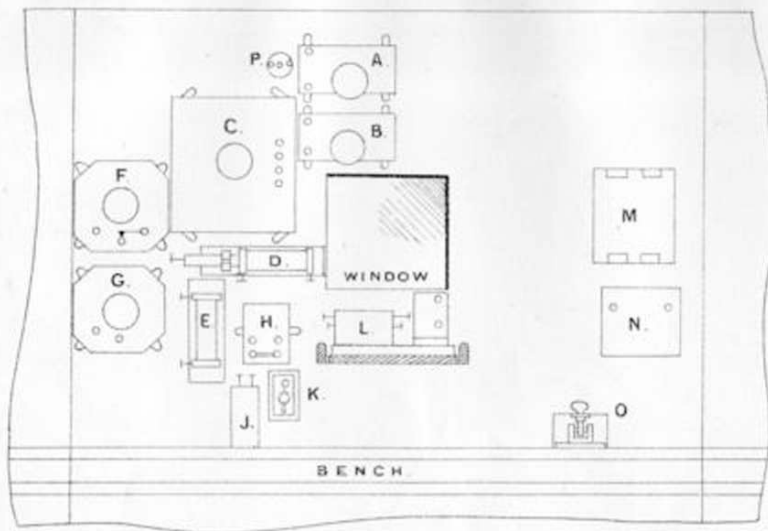

Fig. 15.

REFERENCE TABLE.

- | | |
|----|---|
| A. | INDUCTANCE AERIAL N° 3. PATT. 980. |
| B. | INDUCTANCE ADJUSTABLE N° 13. PATT. 1129. |
| C. | INDUCTANCE MUTUAL N° 34. PATT. 605. |
| D. | INDUCTANCE MUTUAL N° 33. PATT. 1473. |
| E. | INDUCTANCE FIXED N° 22. PATT. 1477. |
| F. | CONDENSER N° 7. PATT. 2486 ^A . |
| G. | CONDENSER N° 12. PATT. 500. |
| H. | TELEPHONE CONDENSER. PATT. 2473. |
| J. | CELL. PATT. |
| K. | POTENTIOMETER. PATT. 562. |
| L. | PROTECTING SWITCH N° 2. PATT. 1186. |
| M. | SWITCH BLOWER STARTING. PATT. 313. |
| N. | CONDENSER FOR MORSE KEY. PATT. 974. |
| O. | KEY MORSE. PATT. 2426. |
| P. | CABINET FITTING. PATT. 567. |

ARRANGEMENT OF RECEIVING INSTRUMENTS.

WITH RESPECT TO POSITION OF WINDOW AND CABINET FITTING.

FOR
REFERENCE TABLE
SEE FIG. 13.

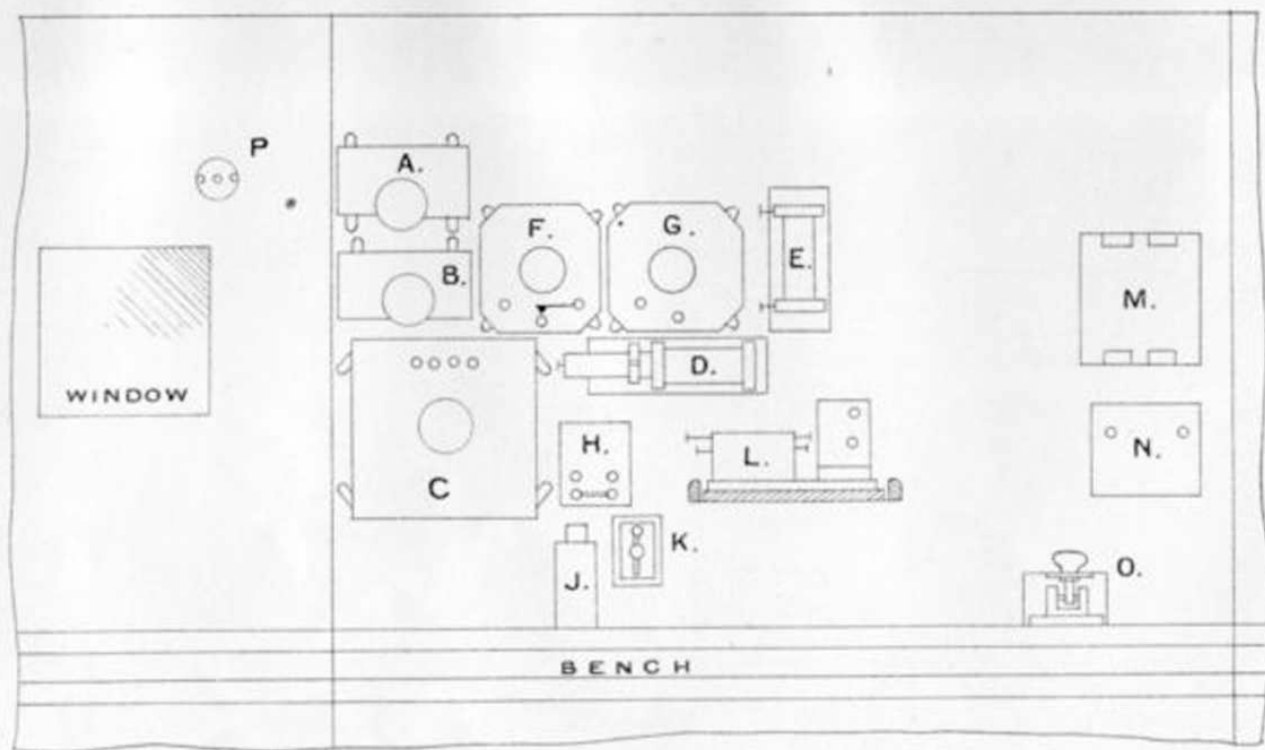
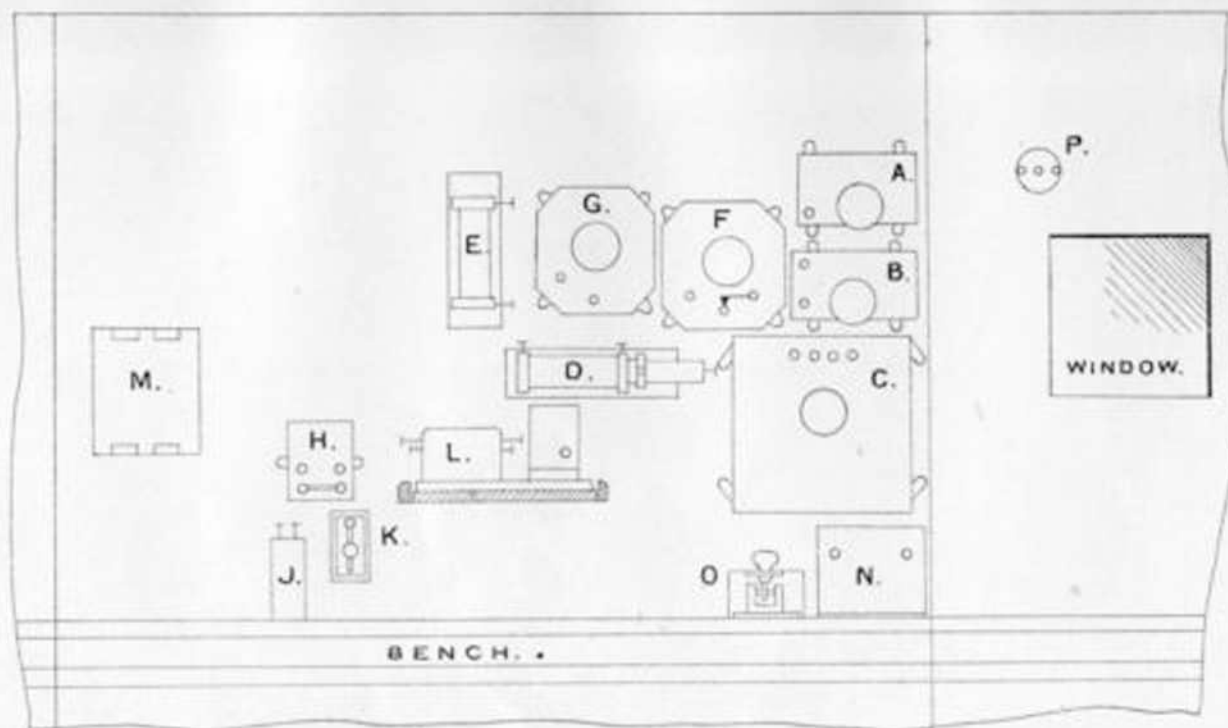

Fig. 16.

ARRANGEMENT OF RECEIVING INSTRUMENTS.

WITH RESPECT TO POSITION OF WINDOW AND CABINET FITTING.



FOR
REFERENCE TABLE
SEE FIG. 13.

Fig. 17.

- POSITIONS OF INSTRUMENTS ON OUTSIDE OF CABINET -

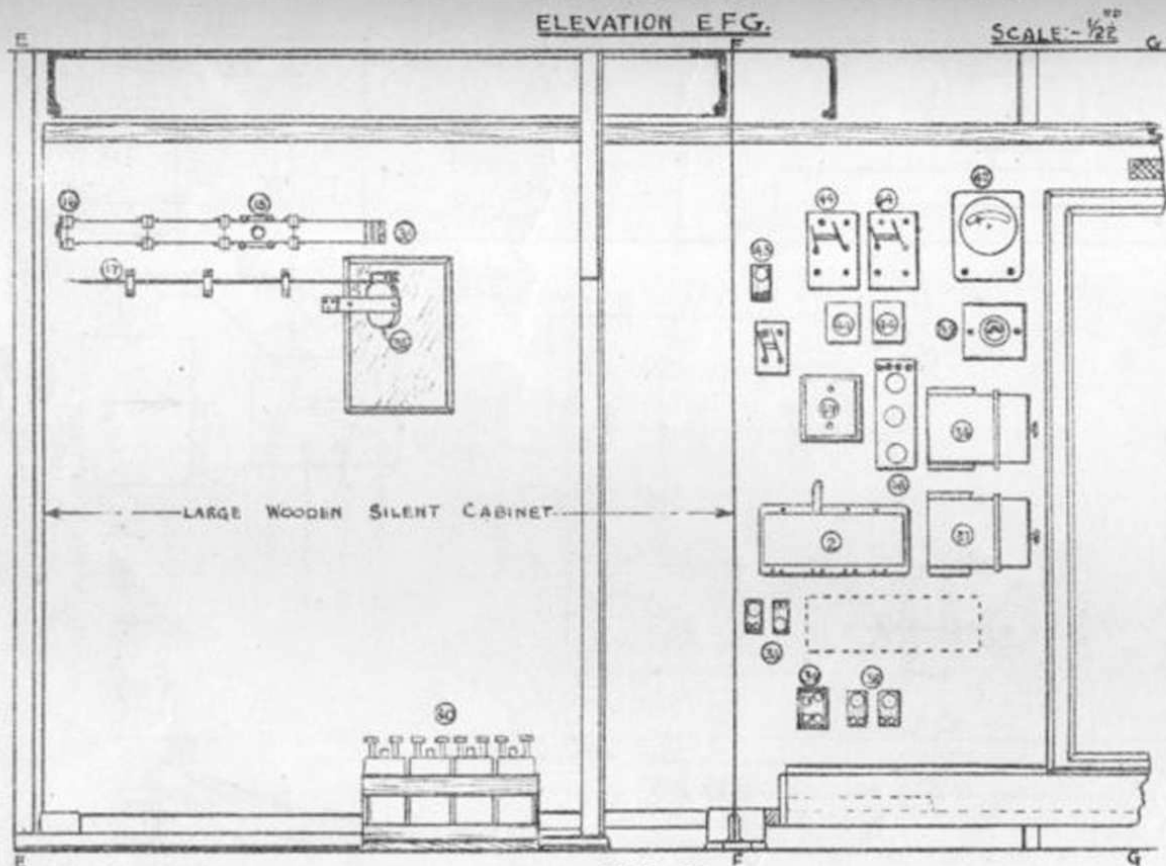

REFERENCE.

NO.	PATT.	DESCRIPTION.
2	509	SWITCH, C.O., 4 - POLE.
15	46A	INSULATOR, PORCELAIN.
16	1450	INSULATOR, PORCELAIN, CLIP.
17	1562	INSULATOR, PORCELAIN, FOR CABLE.
34	567	FITTING, CABINET.
35	568	RADIATION METER.
36	3162 / 714	REGULATOR (speed) FOR MOTOR.
37	3163 / 714	REGULATOR (field) FOR ALTERNATOR.
38	4548	LAMPHOLDER.
39	2528	SWITCH, TELEPHONE.
40	970	CELLS, ACCUMULATOR, 2V, 100 AMP.HR.
41	4809	SWITCH, C.O., 2 POLE, 15 AMPS.
42	377 / 7002	AMMETER, D.C.
42	4548	LAMPHOLDER.
44	1549	SWITCH, C.O., 2 POLE, 5 AMPS.
45	5807 / 714	FIELD REQ. FOR PATT. 5754 GEN.
46	513	SWITCH, STARTING.
47	5674	INDUCTANCES & CONDENSERS, CUSHIONING.
48	4845	POTENTIOMETER.

FIG. 8.

TYPE 9 - POSITIONS OF INSTRUMENTS. -

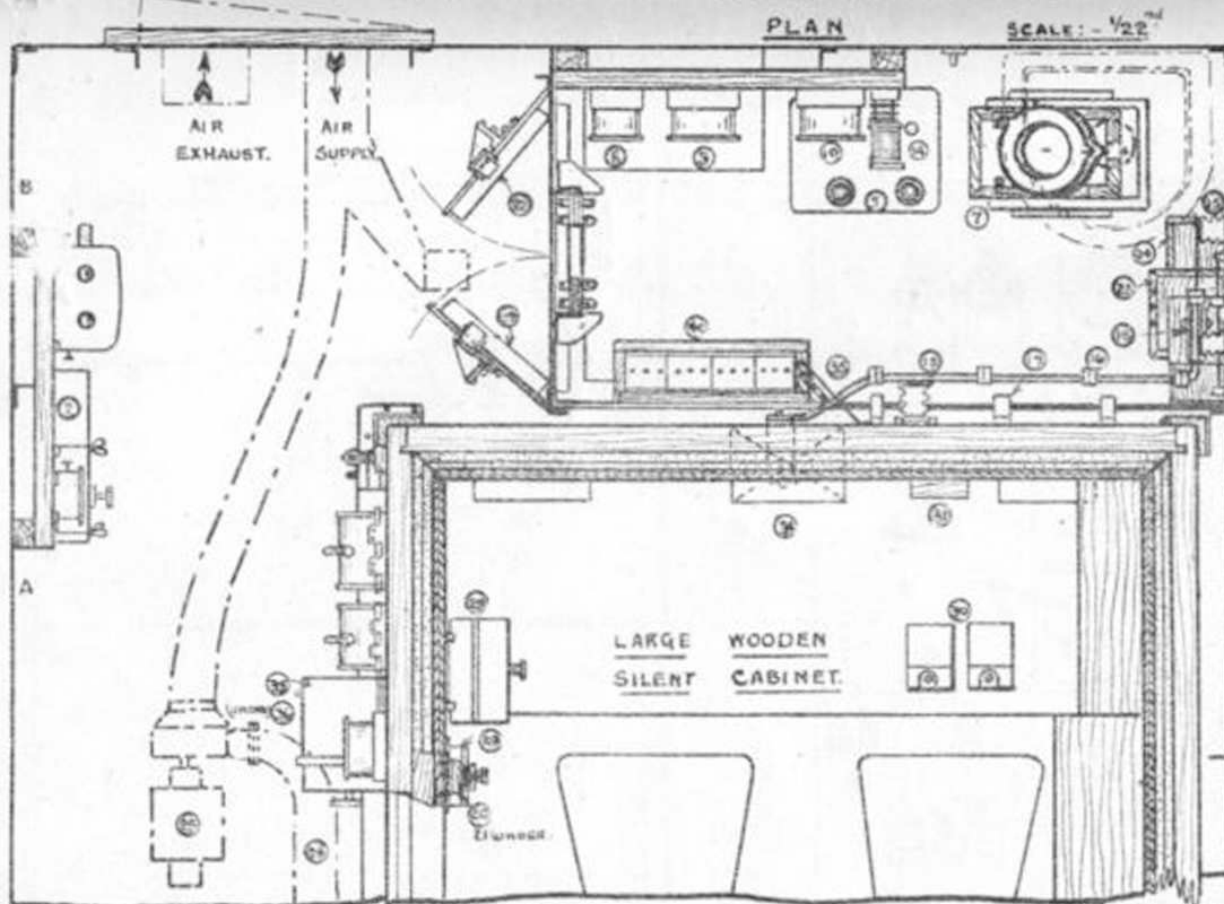

REFERENCE.

NO.	PATT.	DESCRIPTION.
1	2509/3	SWITCH, REGULATING, FOR CIRCULATOR.
2	1509/1	SWITCH, C.O., 4 - POLE.
3	534	SWITCH, C.O., 2 - POLE 30 AMPS.
4	25/34	RADIATOR.
5	341	TRANSFORMER TYPE 3.
6	528	CONDENSER, T., GLASS.
7	-	PRIMARY <i>etc.</i>
8	978	FREQUENCY METER.
9	979	VOLTMETER, TYPE 9.
10	117/202	AMMETER, D.C.
11	604	COIL, IMPEDANCE.
12	23	CUT-OUT, 50 AMPS, D.P.
13	22	CUT-OUT 50 AMPS S.P.
14	253	COILS, PROTECTING.
15	46A	INSULATOR, PORCELAIN.
16	150	INSULATOR, PORCELAIN CLIP.
17	1562	INSULATOR, PORCELAIN, FOR CABLE.
18	5221	KEY, MAGNETIC.
19	1531	SHUNT FOR RADIATION METER.
20	525	SWITCH, NON W-T. FOR CIRCULATOR.
21	325	SWITCH, NON W-T. FOR EMERGENCY SET.
22	1148	SWITCH, SEND RECEIVE.
23	1670	COIL FOR EMERGENCY SET.
24	1552A	BOX, COMPLETE WITH 5 CELLS, PATT 1551 A.
25	2760A 2781A	CIRCULATOR.
26	2316	HOSE, VENTILATING.
27	1202	SAFETY SWITCHES
28	3175/72	STARTER FOR MOTOR ALTERNATOR.
29	5105	STARTER & REGULATOR FOR PATT. 5102 MOTOR.
30	2426	KEY, MORSE.
31	974	CONDENSER FOR MORSE KEY.
32	5521	BATTERY, ACCUMULATOR, 26V.
33	1153	INSULATOR, PORCELAIN PILLAR.

FIG. 7.